



VGD20...



VGD40.../VGD41...

Double Gas Valves

**VGD2...
VGD4...**

- Double gas valves of class «A» for integration into gas trains
- Safety shutoff valves conforming to EN 161 in connection with SKP... actuators
- Suited for use with gases of gas families I...III
- Double gas valves in connection with SKP... actuators open slowly and close rapidly
- 2-port valves of the normally closed type
- Sizes 1 ½“... DN150
- The double gas valves are designed for combination with 2 actuators
- Supplementary Data Sheets on actuators: Refer to «Mechanical design»

The VGD2... / VGD4... and this Data Sheet are intended for use by OEMs which integrate the double gas valves in their products!

Use

The double gas valves are used primarily:

- On gas-fired combustion plant
- In gas trains in connection with forced draft gas burners

They serve as:

- Shutoff valves (in connection with SKP1... actuators)
- Control valves with shutoff feature (in connection with SKP2..., SKP5... or SKP7... actuators)

All types of double gas valves can be combined with any type of SKP... actuator.

Warning notes



To avoid injury to persons, damage to property or the environment, the following warning notes should be observed!

Do not open, interfere with or modify the double gas valves!

- All activities (mounting, installation and service work, etc.) must be carried out by qualified staff
- Fall or shock can adversely affect the safety functions. Such valves must not be put into operation, even if they do not exhibit any damage

Mounting notes

- Ensure that the relevant national safety regulations are complied with
- No special tools are required to assemble valve and actuator
- The actuator can be fitted or replaced while the valve is under gas pressure
- When using a 2-stage SKP10.123... actuator and an actuator with gas pressure governor, fit the SKP10.123... on «V2». Mount the actuator with the gas pressure governor (e.g. SKP20..., SKP25...) on «V1» («V2» is the valve on the burner side)
- Also observe the following Mounting Instructions:

- VGD...	M7631	4 319 2343 0
	M7636	4 319 2072 0
- AGA40...51	M7631.1	4 319 2142 0
- VGD40...	M7631.2	74 319 0244 0
- VGD40...U	M7631.3	74 319 0278 0

Tightness

- No sealing material is required when fitting the actuators
- Check to ensure that the bolts on the flanges are properly tightened
- Check to ensure that the connections with all components are tight
- Make certain that the O-rings and gaskets between the flanges and the double gas valve are fitted

Mounting position

The double gas valve itself can be mounted in any position in the gas train, but the permissible mounting positions of the actuators must be observed (refer to the relevant Data Sheets).

Direction of flow

The direction of gas flow must be in accordance with the direction of the arrow on the valve body.

When used in combination with actuators, the minimum gas pressure switch must always be mounted upstream of the gas valve.

Function

Valve stem retracts → Double gas valve opens
Valve stem extends → Double gas valve closes

VGD20...

- Mount the electrohydraulic SKP1... actuator for shutoff on the valve's inlet side and the actuators with integrated gas pressure governor (SKP2..., SKP5... or SKP7...) on the valve's outlet side
- When mounting the double gas valve, 2 AGA41... / AGA51... flanges are required
- To prevent cuttings from falling inside the valve, first fit the flanges to the piping and then clean the associated parts

Installation notes

Gas pressure If the available gas pressure exceeds the valve's maximum permissible operating pressure, the gas pressure must be reduced by a pressure regulator upstream of the valve.

Commissioning notes

- If environmental conditions produce corrosion (e.g. when used near the sea), apply protective coating

Standards and certificates



Conformity to EU directives

- Electromagnetic compatibility EMC (immunity) 89 / 336 / EEC
- Directive for gas-fired appliances 90 / 396 / EEC
- Directive for pressure devices 97 / 23 / EC



ISO 9001: 2000
Cert. 00739



ISO 14001: 2004
Cert. 38233

For use in the U.S. / Canada, the valves carry type suffix «U» (see example) and are and listed.

Example: VGD20.403**U**27

In connection with actuator

Type reference			
VGD20.403	x	x	x
VGD20.503	x	x	x
VGD20.4011	x	x	x
VGD20.5011	x	x	x
VGD40.040	x	x	x
VGD40.050	x	x	x
VGD40.065	x	x	x
VGD40.080	x	x	x
VGD40.100	x	x	x
VGD40.125	x	x	x
VGD40.150	x	x	x
VGD40.040L	x	x	---
VGD40.050L	x	x	---
VGD40.065L	x	x	---
VGD40.080L	x	x	---
VGD40.100L	x	x	---
VGD40.125L	x	x	---
VGD40.150L	x	x	---
VGD41.040	---	x	---
VGD41.050	---	x	---
VGD41.065	---	x	---
VGD41.080	---	x	---
VGD41.100	---	x	---
VGD41.125	---	x	---
VGD41.150	---	x	---

Service notes

- Each time a double gas valve has been replaced, check the correct functioning and the internal and external tightness of the valve
- The double gas valves from Siemens may **only** be overhauled by Siemens Repair Centers

Disposal notes



Local and currently valid legislation must be observed.

Mechanical design

Strainer

A strainer made of stainless steel is fitted near the valve's inlet to protect the valve, the seat and the disk as well as downstream devices against dirt.

AGA41 / AGA51 connecting flanges for VGD20...

The connecting flanges have a ¼" test point. They are internally threaded and supplied as separate items together with the necessary accessories, such as bolts, nuts, and seals. The overall flange dimensions and bore-holes are identical so that all types of flanges can be fitted to the double gas valve, irrespective of nominal size. This means that a 1 ½" flange can also be used with a 2" double valve, and vice versa. Each double gas valve requires 2 connecting flanges.

VGD20...

Functioning principle

Sectional view of VGD20...

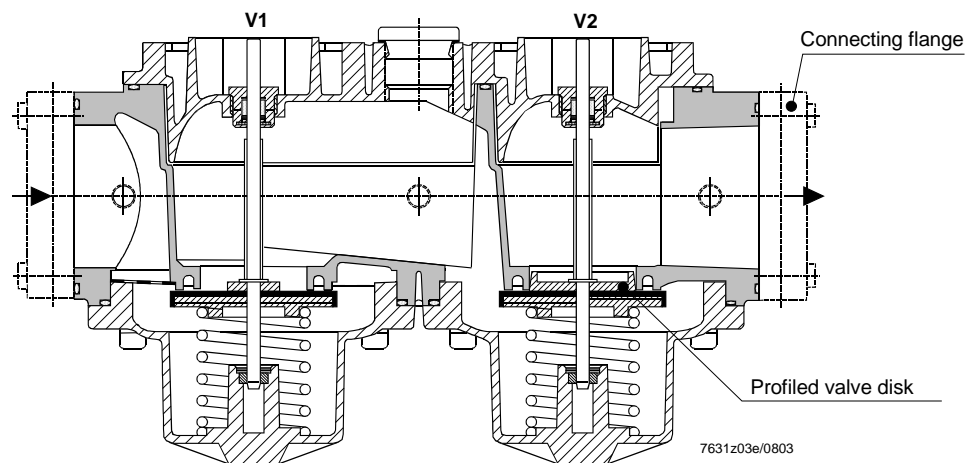

Application example

VGD20... with SKP1... (mounted on «V1») and SKP7... (mounted on «V2»)



Mechanical design (cont'd)

VGD4...

The VGD4... double gas valves are double-seat disk valves. The ¼" impulse pipe connection on the pilot gas flange and another impulse pipe connection on the outlet flange can be connected directly to the SKP2... constant pressure governor fitted to «V1» or «V2».

Closing spring

The patented double seats are closed with the help of 2 springs. One of the springs acts on one valve disk so that there is defined closing force acting on each disk.

Pressure switch plate

Pressure switch plate ① facilitates attachment of a number of commercially available pressure switches or valve proving devices. Pilot gas flange ② and pressure switch plate can be fitted on either side of the valve.

VGD4...

Functioning principle

Sectional view of VGD4...

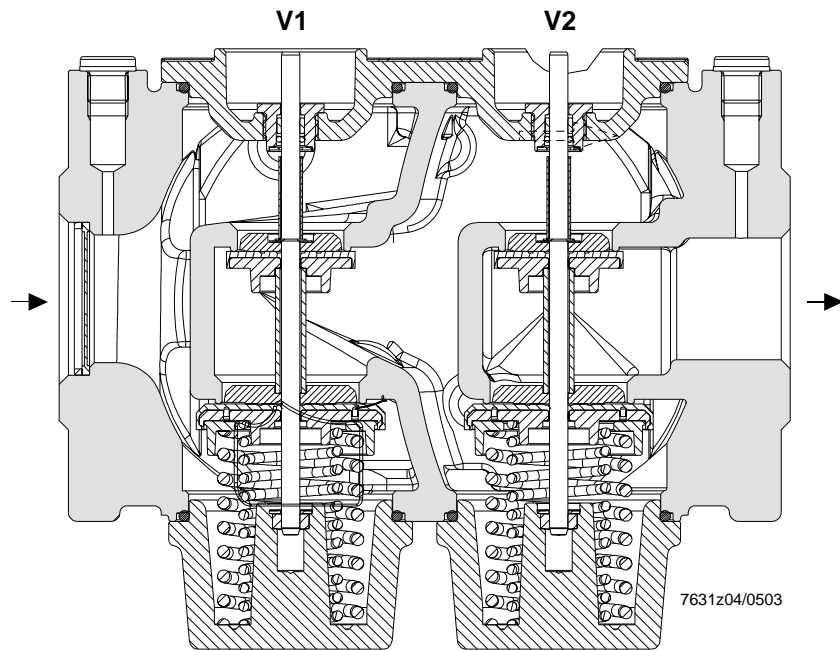

Application example

VGD40.080 with SKP1... (mounted on «V1») and SKP2... (mounted on «V2»)

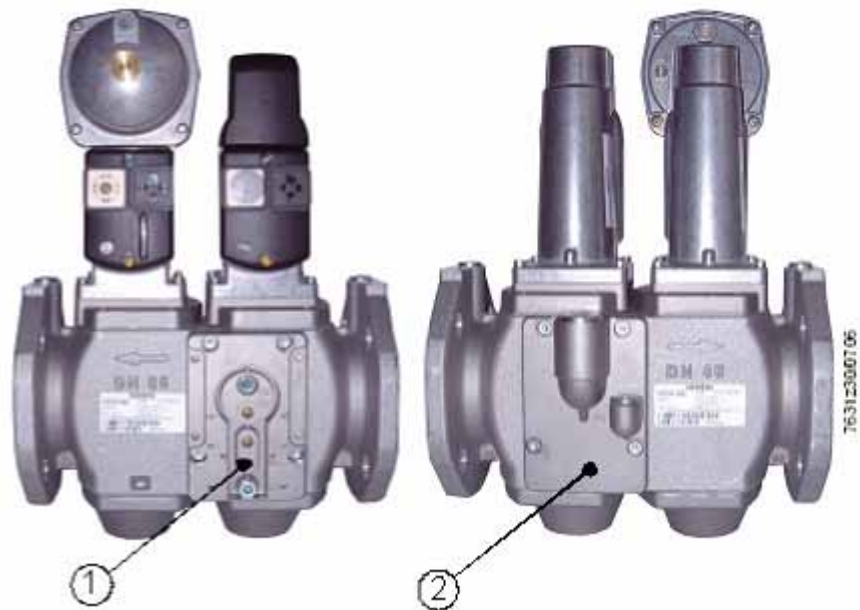

Actuators

The double gas valves can be combined with the following types of actuators:

Type reference	Data Sheet	Function
SKP10...	N7641	ON / OFF
SKP11...	N7641	ON / OFF
SKP15...	N7643	ON / OFF
SKP20...	N7644	ON / OFF with constant pressure control / zero pressure control
SKP25...	N7644	ON / OFF with constant pressure control / zero pressure control
SKP25.7...	N7644	ON / OFF with pressure control, predefined set-point adjustable via electrical signal
SKP50...	N7648	ON / OFF with differential pressure control, signal input → differential pressure
SKP55...	N7648	ON / OFF with differential pressure control, signal input → differential pressure
SKP70...	N7651	ON / OFF with fuel / air ratio control, signal input → static pressure
SKP75...	N7651	ON / OFF with fuel / air ratio control, signal input → static pressure
SQX32... with AGA60	N4554	Modulating 3-position positioning control

Type summary (other types of valves on request)

VGD2...

	Flow rate at $\Delta p = 10 \text{ mbar m}^3/\text{h air}^1)$	Type reference	
		With 3 threaded holes for connections	With 11 threaded holes for connections
1 1/2"	85	VGD20.403	VGD20.4011
2"	100	VGD20.503	VGD20.5011

VGD4...

DN	Flow rate at $\Delta p = 10 \text{ mbar m}^3/\text{h air}^1)$	Type reference		
			³⁾	⁴⁾
40	85	VGD40.040	VGD40.040L	VGD41.040
50	100	VGD40.050	VGD40.050L	VGD41.050
65	160	VGD40.065	VGD40.065L	VGD41.065
80	250	VGD40.080	VGD40.080L	VGD41.080
100	400	VGD40.100	VGD40.100L	VGD41.100
125	580 (630 ²⁾)	VGD40.125	VGD40.125L	VGD41.125
150	700 (800 ²⁾)	VGD40.150	VGD40.150L	VGD41.150

- 1) Flow rate conforming to EN 161
- 2) Only with VGD40...: Flow rate in connection with future line of actuators
- 3) VGD40...L with reversed position of mounting plates (refer to «Dimensions»)
- 4) VGD41... with pressure switch plate on both sides (refer to «Dimensions»)

Ordering

When ordering, please give type reference of the double gas valve.

Actuators must be ordered as separate items.

Double gas valve, flanges (only VGD20...) and actuators are supplied as separate items.

Example: VGD20...

Double gas valve 2" complete with 2 connecting flanges

1 VGD20.503

2 AGA51

Example: VGD4...

Double gas valve DN80

1 VGD40.080

The lateral mounting plates (pilot gas connection and pressure switch plate) are included in the scope of delivery and ready fitted.

VGD40...L

Direction of gas flow from left to right, universal mounting plate on the front.

Accessories

Connecting flanges for
VGD20... / VGD40...

Type reference of valve ¹⁾	Type reference of connecting flange
VGD20.403 1 1/2"	AGA41
VGD20.503 2"	AGA51
VGD20.4011 1 1/2"	AGA41
VGD20.5011 2"	AGA51

¹⁾ Internally threaded to ISO 7/1

Pressure switch connecting plate for VGD40...

AGA40.41

- Spare part (kit incl. grommet and gaskets)

Pilot gas connecting plate for VGD40...

AGA40.40

- Spare part (kit incl. grommet and gaskets)

Assembly VGD... /
SKP...

Assembly VGD4...

- Only on request
- Complete assembly consisting of double gas valve, actuator, pressure switch, connecting cable and impulse pipe (fitted and tested)
- Packed in a cardboard box and labeled

Technical data

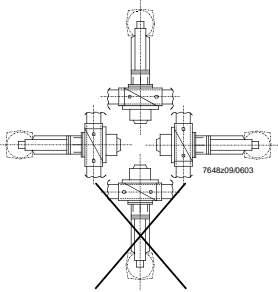
General valve data	Valve class (in connection with actuator)	«A» conforming to EN 161
	Group	2 (EN 161)
	Perm. medium temperature	-15...60 °C
	Weight	
	- VGD20...	approx. 3.2 kg
	- VGD40...	refer to «Dimensions»
	Connecting flanges for VGD40...	PN16 to ISO 7005-2
	Required flow rate	refer to «Flow chart»
	Mounting position	
		
	refer to «Mounting notes»	
Operating pressure	refer to «Type summary»	
Type of gas	refer to «Use»	
Strainer	built in (mesh size 0.9 mm)	
Materials	nonferrous (only VGD40...)	
Environmental conditions	Storage	DIN EN 60721-3-1
	Climatic conditions	class 1K3
	Mechanical conditions	class 1M2
	Temperature range	-20...+60 °C
	Humidity	< 95 % r.h.
	Transport	DIN EN 60 721-3-2
	Climatic conditions	class 2K2
	Mechanical conditions	class 2M2
	Temperature range	-15...+60 °C
	Humidity	< 95 % r.h.
	Operation	DIN EN 60 721-3-3
	Climatic conditions	class 3K5
	Mechanical conditions	class 3M2
	Temperature range	-10...+60 °C
	Humidity	< 95 % r.h.



Condensation, formation of ice and ingress of water are not permitted!

Permissible gas pressures / volumes

Type reference	Static pressure (with double gas valve fully closed) (mbar)	Dynamic pressure (perm. operating pressure) (mbar)	Volume between «V1 / V2» (liters)
VGD20.403	600	600 (1400)*	0.75
VGD20.503	600	600 (1400)*	0.8
VGD20.4011	600	600 (1400)*	0.75
VGD20.5011	600	600 (1400)*	0.8
VGD40.040	1500	1000 (700)*	0.8
VGD40.050	1500	1000 (700)*	0.8
VGD40.065	1500	700	1.3
VGD40.080	1500	700	1.5
VGD40.100	1500	700	3
VGD40.125	1500	700	5.2
VGD40.150	1500	700	8.7

* Only for use in Australia

Technical data (cont'd)

VGD40...

The double gas valves are designed to withstand gas pressures up to 1,500 mbar in burner standby mode. At a pressure of 1,500 mbar, the double valve remains safely shut or will safely close when shutdown is initiated by an upstream pressure signal. Proper functioning and outer tightness will not be affected.

Note:

Owing to the internal design of the double valves, increasing inlet pressure causes the valve to close (class «A» conforming to EN 161). This means that safety shutoff or venting devices that – in addition to the high-pressure regulator – are normally used for protecting the gas valve on the burner are no longer required if the following conditions are satisfied: If, in the event the high-pressure regulator upstream of the valve fails, 1,500 mbar at the inlet of the double valve are not exceeded and, in the event the permissible pressure of the double valve is exceeded (DN65...150: 700 mbar or DN40...50: 1,000 mbar), a shutoff device (e.g. gas pressure switch) causes the double valve to close.

Possibilities of fitting the pressure switch to the VGD2...

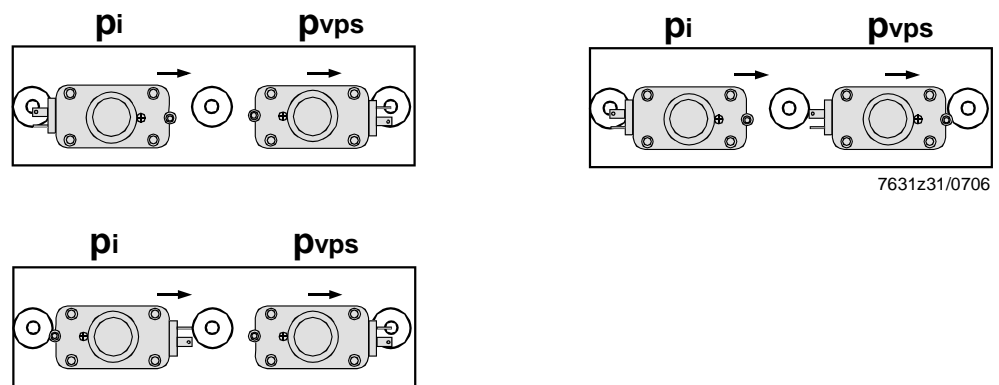

Possibilities of fitting the pressure switch to the VGD4...

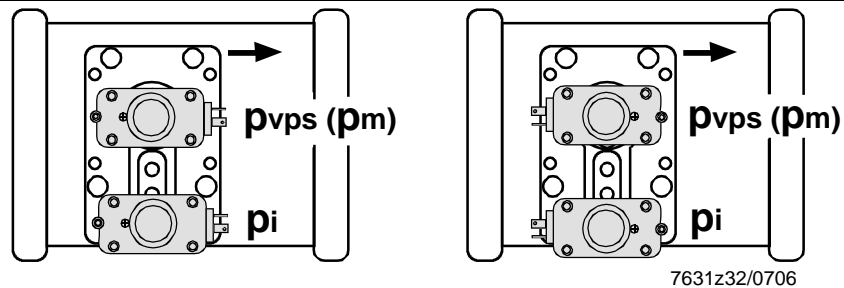

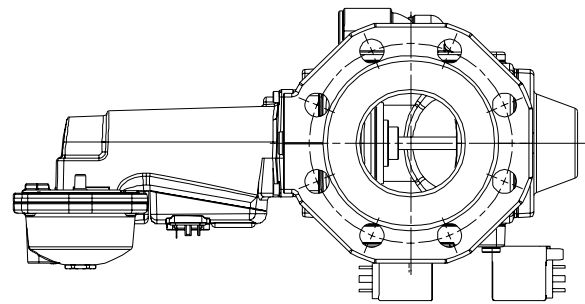
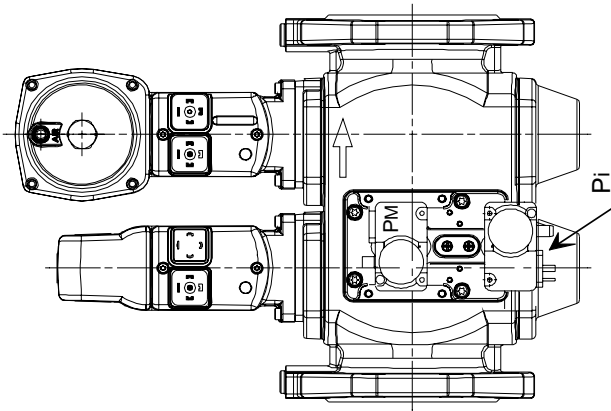

7631z34e/0906

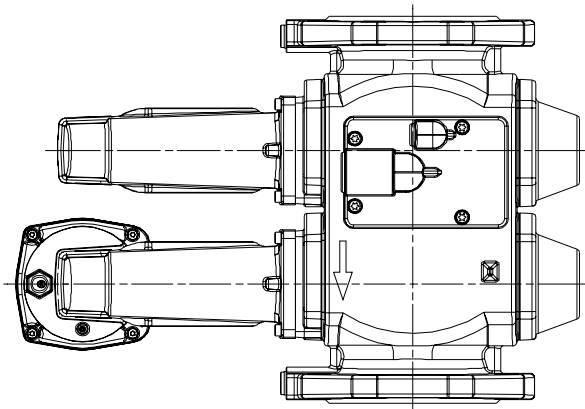

Ancillary unit options (use of different types of valve proving systems on request):

Valve proving device "A" and pressure switch (Pi)

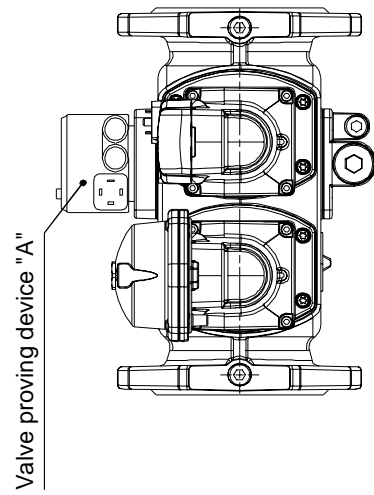

Valve proving device "B" and pressure switch (Pi)

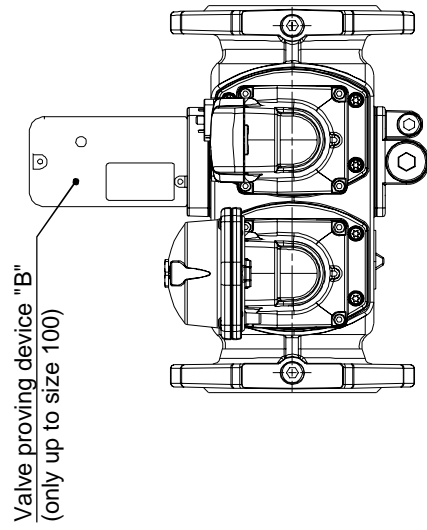

2 pressure switches (PM, Pi)

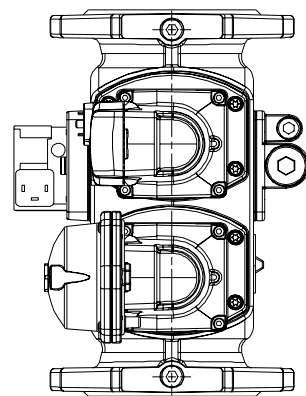

(Some of the ancillary units are products of other manufacture)

Flow chart of VGD... (only for fully open double valves)

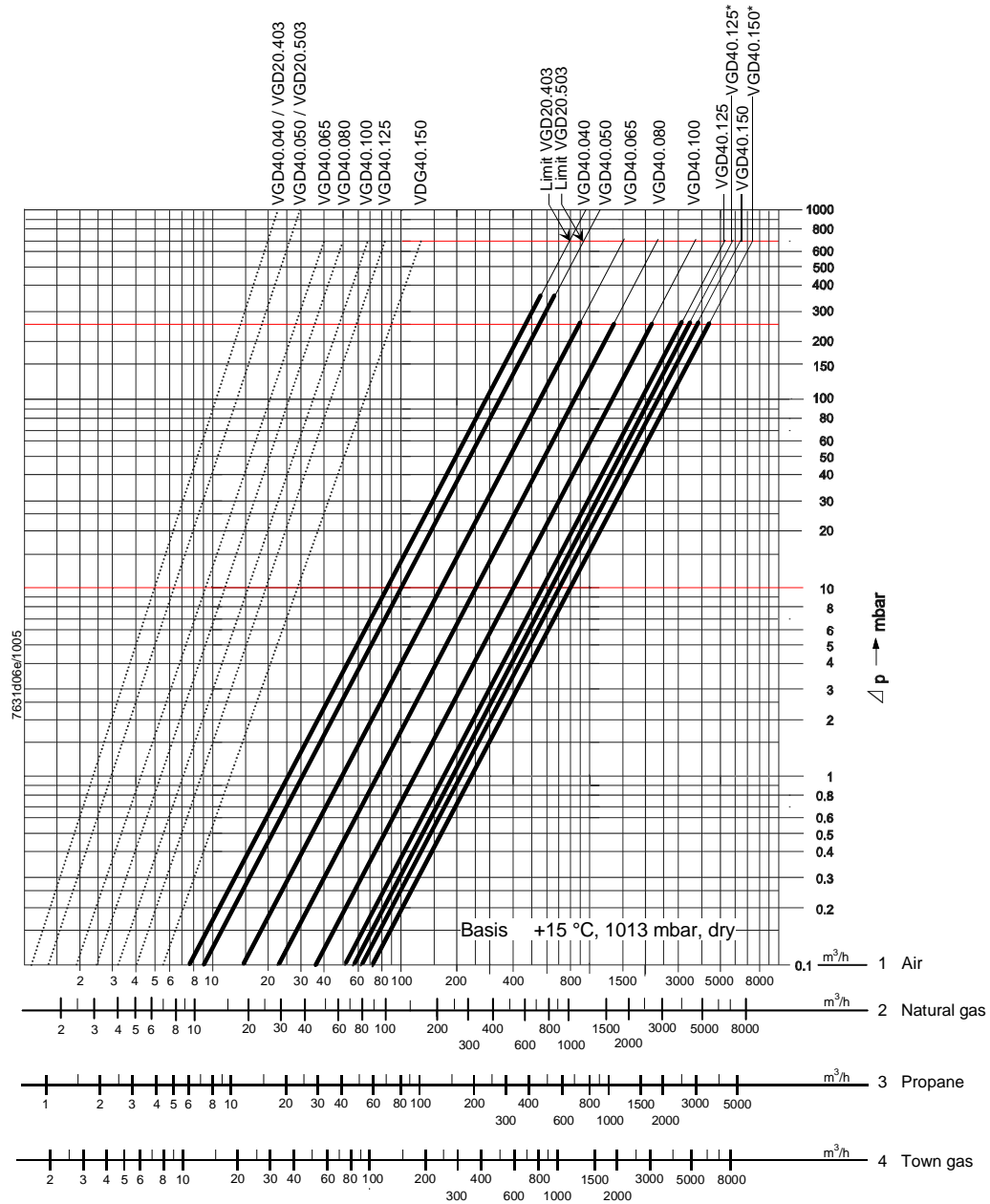

Legend:

- * Characteristic only available in connection with future line of actuators
- Minimum flow characteristic
- Maximum flow characteristic (double gas valve fully open)

Practical experience shows that applications in the range confined by the bold characteristics (max. 70 m / s) do not produce significant noise.

Note:

- In the case of burners with small low-fire volumes, select a tightly sized valve (refer to the relevant Data Sheets on actuators)
- If the gas pressure exceeds the maximum permissible operating pressure, reduce it with a pressure regulator installed upstream of the valve
- The pressure drop (at maximum flow) is based on a fully open valve

Conversion of the air volume to a corresponding gas volume (natural gas)

Basis of scale

Abcissa	Medium Volumetric flow «QG» in m³ / h	Density ratio «dv» to air	Conversion factor $f = \sqrt{\frac{1}{d_v}}$
1	Air	1	1
2	Natural gas	0.61	1.28
3	Propane	1.562	0.8
4	Town gas	0.46	1.47

Conversion to air (m³ / h) from other types of gases: $QL = \frac{QG}{f}$ QL = amount of air m³ / h producing the same pressure drop as «QG»

Example: Recommended working range (extract of VGD... flow chart)

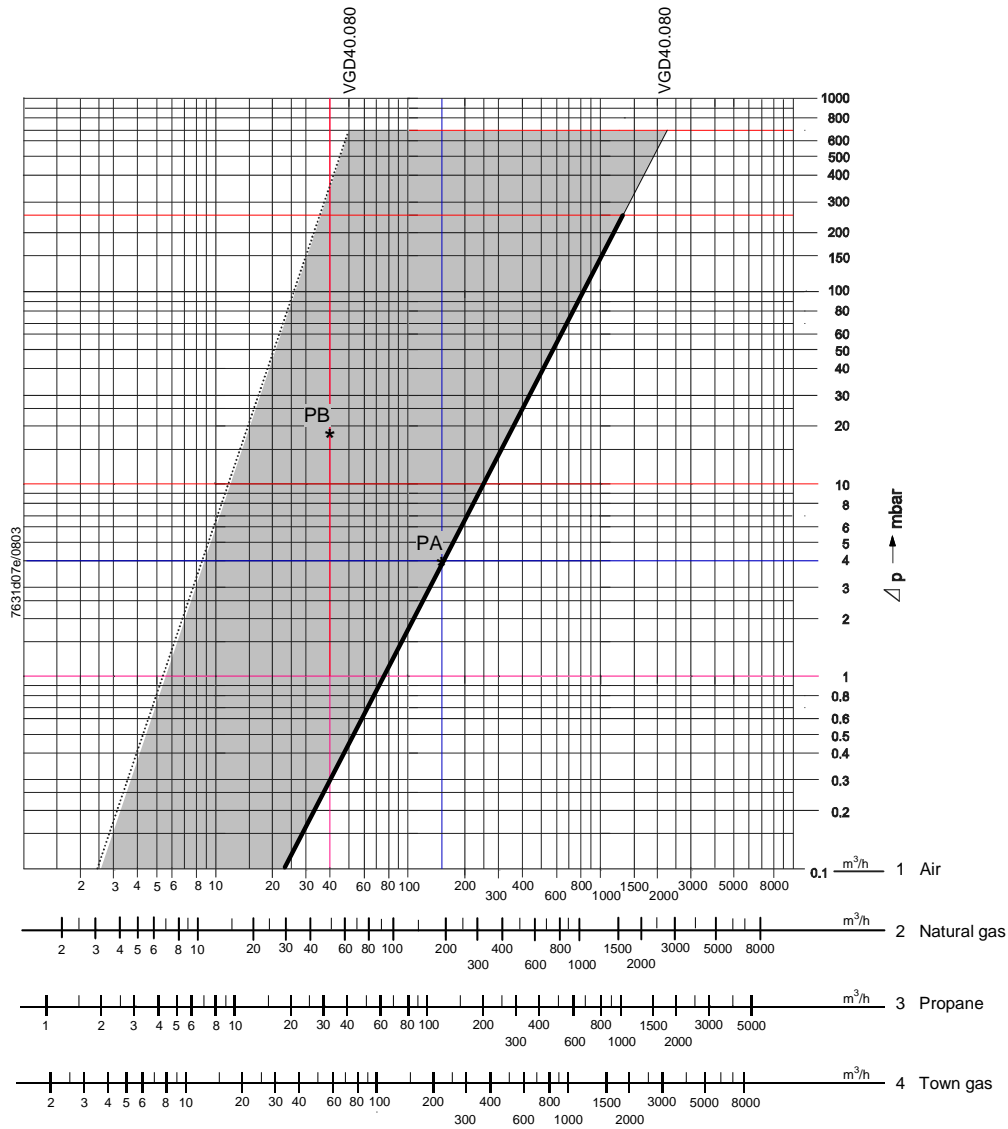

- Legend**
- Minimum flow characteristic (can vary, depending of the quality of the pressure test points)
 - Maximum flow characteristic (double gas valve fully open)
 - PA Working point
 - PB Working point

For points «PA / PB», refer to «Sizing example» below.

Sizing example

Simplified example based on the above sizing chart: VGD... with SKP7...

Prerequisite	Burner gas outlet toward the combustion chamber
Simplified example: Constant combustion chamber pressure	= 0 mbar
Required control ratio	RV = 4 : 1
Gas inlet pressure	20 mbar

1. **High-fire** → Point «PA» in the highlighted area
 Burner pressure at nominal load 16 mbar
 Volumetric flow at nominal load 200 m³ / h natural gas, corresponding to 156 m³ / h air
 - ΔpV... at nominal load 20 - 16 = 4 mbar
 Point «PA» must be on or to the left of the line representing the maximum flow characteristic
2. **Low-fire** → Point «PB» in the highlighted area
 $PG_{min} = \frac{PG_{max}}{RV^2} = \frac{16 \text{ mbar}}{16} = 1 \text{ mbar}$ (Δp chart = 20 - 1 = 19 mbar)
 $VG_{min} = \frac{VG_{max}}{RV} = \frac{200 \text{ m}^3/\text{h}}{4} = 50 \text{ m}^3$ corresponding to $h = 39 \text{ m}^3/\text{h}$ air
 - Selected valve size VGD40.080
 Point «PB» must be on or to the right of the line representing the minimum flow characteristic.

Dimensions (not to scale)

Dimensions in mm

VGD20.403 / VGD20.503

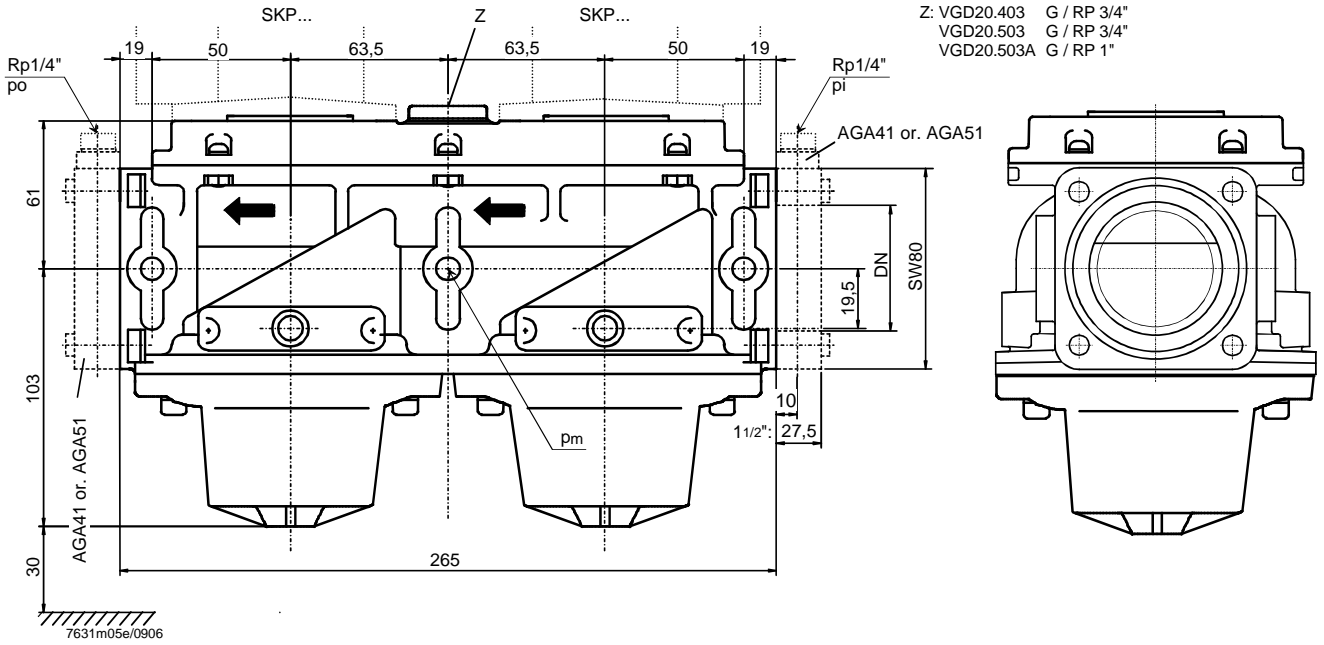

VGD20.4011 / VGD20.5011 (for dimensions, refer to VGD20.403 / VGD20.503)

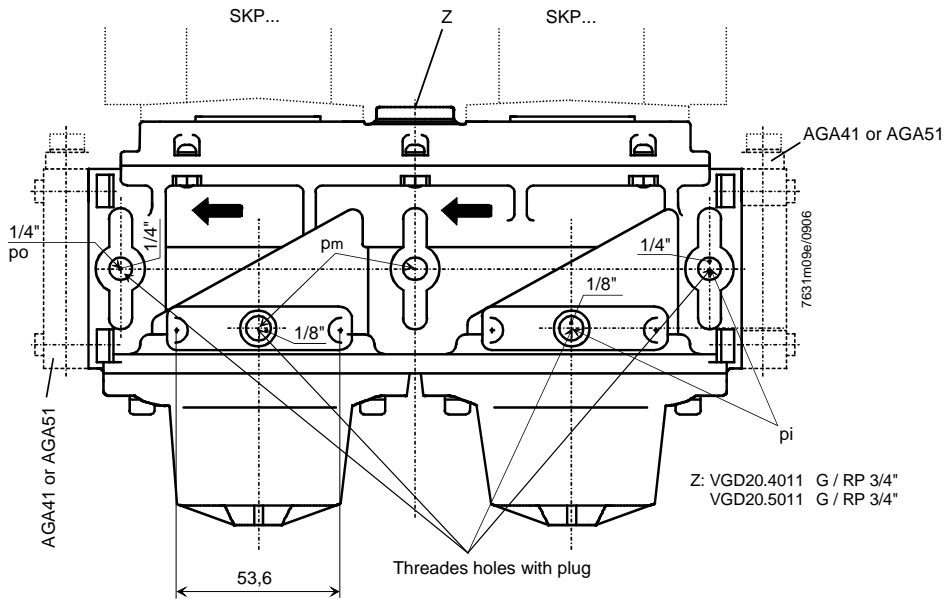

Blind hole for thread-forming screws M4!

Dimensions (cont'd)

(Not to scale)

VGD40... / VGD41...

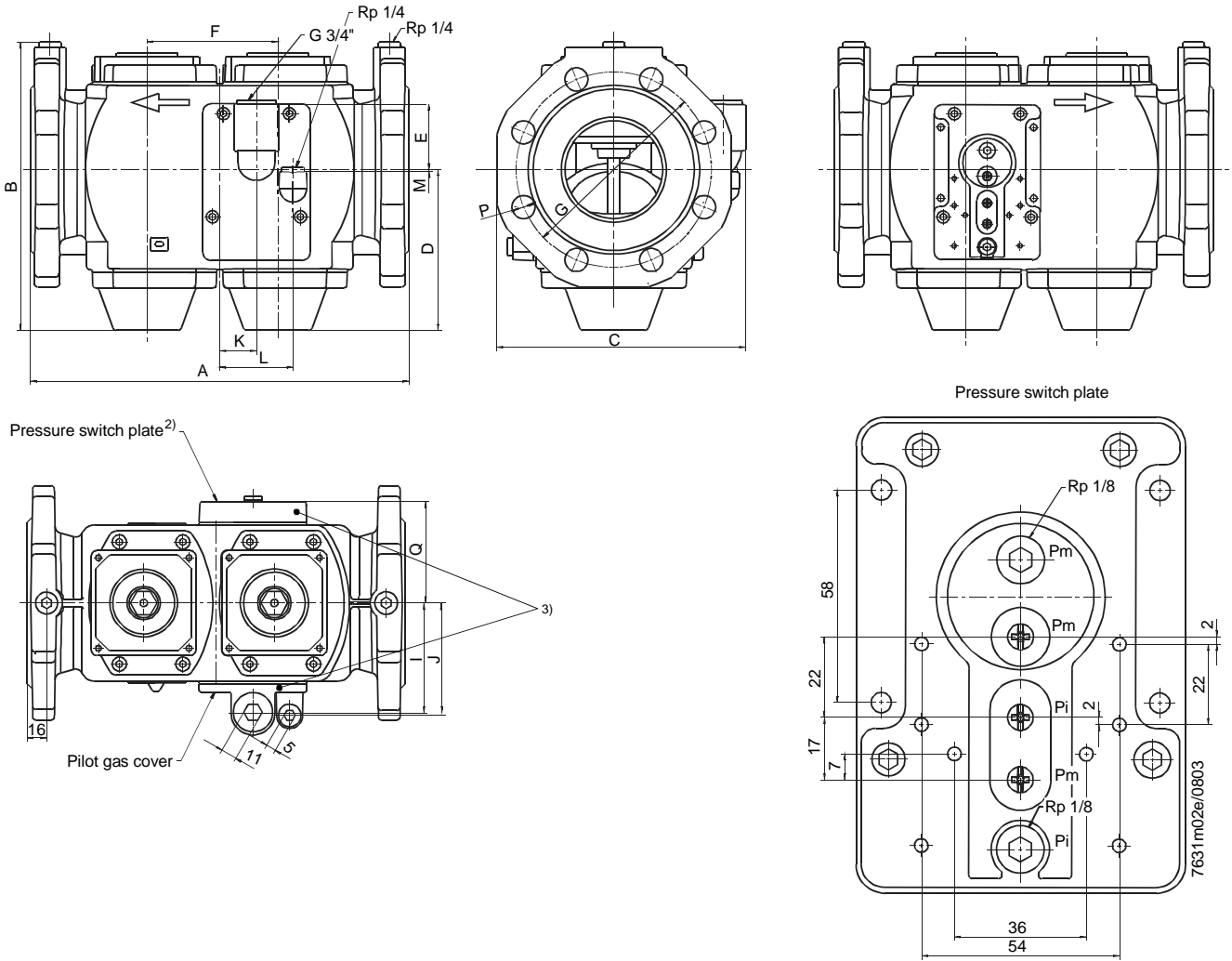

Dimensions

Type reference	DN 1)	A	B	C	D	E	F	G	I	J	K	L	M	P	Q	R	kg
VGD40.040	40	240	195	168	115	58	88	110	77	79	20	50	2	19	70	4	7.0
VGD40.050	50	240	202	174	115	58	88	125	77	79	20	50	2	19	70	4	7.2
VGD40.065	65	290	215	194	118	60	102	145	87	90	30	60	4	19	81	4	8.4
VGD40.080	80	310	236	204	132	54	107	160	90	92	30	60	2	19	88	8	9.6
VGD40.100	100	350	259	227	145	43	131	180	105	108	41	71	13	19	99	8	12.9
VGD40.125	125	400	305	255	175	31	150	210	119	122	41	71	25	19	113	8	18.2
VGD40.150	150	480	335	293	188	20	168	240	140	143	39	69	36	23	134	8	24.1

- 1) Flanges conforming to ISO 7005-2
- 2) VGD41... carries a pressure switch plate on both sides and no pilot gas cover
- 3) With VGD40...L, the mounting position of the 2 plates is reversed
- DN Nominal size, dimensions of connection
- R Number of bore-holes in the flange