

## Duct sensor

for relative humidity and temperature

## QFM65



---

**Operating voltage AC 24 V,  
output signals DC 0...10 V**

### Use

In ventilating and air conditioning plants for acquiring

- the relative humidity and
- the temperature in air ducts

The QFM65 is used as a

- control sensor in the supply or extract air duct
- shift sensor, e.g. for shifting the dew point
- limit sensor, e.g. in connection with steam humidifiers
- limit sensor, e.g. for measured value indication or for interfacing with a building management system
- sensor for enthalpy and absolute humidity, together with the AQF61.1 (refer to data sheet 1899)

### Ordering

When ordering, please give name and type reference: duct sensor **QFM65**.

### Equipment combinations

All systems and devices that are capable of acquiring and handling the sensor's DC 0...10 V output signals.

### Mode of operation

#### Relative humidity

The sensor senses the relative humidity with the help of a capacitive humidity measuring element whose electrical capacity changes in function of the relative humidity of the ambient air.

An electronic measuring circuit converts the sensor's signal to a continuous DC 0...10 V output signal, corresponding to 0...10 % relative humidity. In the range 1...9 V ( $\cong$  10...90 % r.h.), the signal is linear to the measuring accuracy given under "Technical data", resulting in an effective measuring range of 10...90 % r.h.

## Temperature

The sensor acquires the temperature with the aid of the Pt1000 thin-film measuring element whose electrical resistance changes in function of the temperature of the ambient air. The change in resistance is converted to two DC 0...10 V signals that act independently. One DC 0...10 V signal corresponds to the temperature range 0...50 °C, the other to -35...+35 °C.

---

## Mechanical design

The duct sensor is comprised of housing, removable cover and immersion sensor stem. The housing accommodates the measuring circuit and the connecting terminals. The cable is introduced through a threaded hole in the bottom for the Pg11 cable gland (IP 42) supplied with the sensor or with another Pg11 cable gland to DIN 46 320 (IP 54).

The sensing elements are located at the end of the immersion sensor stem and are protected by a protective sleeve with a filter.

Immersion sensor stem and sensor housing are made of plastic and rigidly connected to one another.

The sensor is secured with the help of screws. It can be fitted in two different ways:

- Using the mounting flange supplied with the sensor. The flange is placed over the stem and secured in accordance with the required immersion depth.
- Without the mounting flange (making use of the maximum immersion depth). For this purpose, the housing has four through-holes.

## Accessories

(supplied with the QFM65)

- Mounting flange
- Cable gland

---

## Engineering notes

The transformer used must be suitable for safety extra low voltage (SELV). It must have separate windings and be suited for 100% duty.

The transformer must be sized and fused in compliance with local safety regulations.

The maximum permissible line lengths should be observed.

---

## Fitting notes

The sensor should be mounted in the middle of the duct wall.

If degree of protection IP 42 is required, the cable entry must point downward!

Important!

- If used in connection with steam humidifiers, the distance to the humidifier must be at least 3 m. If permitted by the installation, the distance to the steam humidifier should be as great as possible, but not more than 10 m.
- The measuring rod's sensing elements are sensitive to impact. Avoid any such impact on mounting.

If the application involves dew point shifting, the sensor must be fitted in the extract air duct.

Mounting instructions are printed on the packing.

---

## Commissioning notes

Check the wiring when commissioning the plant. No adjustments are required on the sensor itself.

## Technical data

General data	Operating voltage (SELV)	AC 24 V $\pm$ 20 %
	Frequency	50 or 60 Hz
	Power consumption	$\leq$ 0.5 VA
	Perm. line lengths	
	Copper cable 0.5 mm dia.	50 m
	Copper cable 1.0 mm <sup>2</sup>	150 m
	Copper cable 1.5 mm <sup>2</sup>	300 m
	Connecting terminals for	2 x 1.5 mm <sup>2</sup>
	Ambient conditions	
	Operation to IEC 721-3-3	class 3K5
	Temperature (ambient, medium)	-5...+50 °C
	Humidity	5...95 % r.h.
	Transport to IEC 721-3-2	class 2K3
	Temperature	-25...+70 °C
	Humidity	<95 % r.h.
	Mechanical ambient conditions	class 2M2
	Degree of protection of housing to EN 60 529	
	With enclosed cable gland	IP 42
	With cable gland to DIN 46 320	IP 54
	CE conformance to EMC directive	89/336/EWG
	Weight	approx. 0.17 kg
Humidity sensor	Range of use	10...90 % r.h.
	Measuring accuracy at 20 °C	
	20...90 % r.h.	$\pm$ 5 % r.h.
	40...60 % r.h. (typically)	$\pm$ 3 % r.h.
	Temperature sensitivity	$\leq$ 0.1 % r.h./°C
	Output signal (linear)	DC 1...9 V $\hat{=}$ 10...90 % r.h. $\pm$ 1 mA max.
	Time constant	approx. 20 s in moving air at 0...50 °C, 10...80 % r.h.
	Perm. air velocity	20 m/s
Temperature sensor	Range of use	0...50 °C and -35...+35 °C
	Measuring element	Pt1000 Class B
	Measuring accuracy at 20 °C	$\pm$ 0.7 K
	Output signals (linear)	
	Voltage at terminal B <sub>at50</sub>	DC 0...10 V $\hat{=}$ 0...50 °C
	Voltage at terminal B <sub>at35</sub>	DC 0...10 V $\hat{=}$ -35...+35 °C
	Current	$\pm$ 1 mA max.
Time constant	approx. 20 s in moving air	

## Connecting terminals

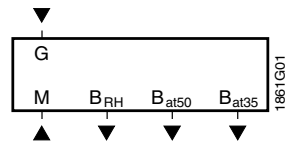

- G, M Operating voltage AC 24 V (SELV)  
 G System potential (SP)  
 M System neutral (SN), measuring neutral
- B<sub>RH</sub> Signal DC 1...9 V for 10...90 % r.h.  
 B<sub>at50</sub> Signal DC 0...10 V for temperature measuring range 0...50 °C  
 B<sub>at35</sub> Signal DC 0...10 V for temperature measuring range -35...+35 °C

## Dimensions

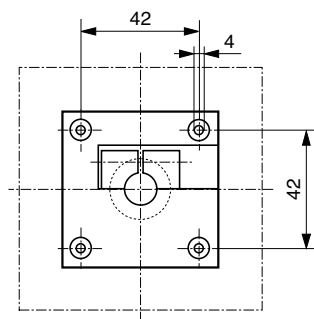
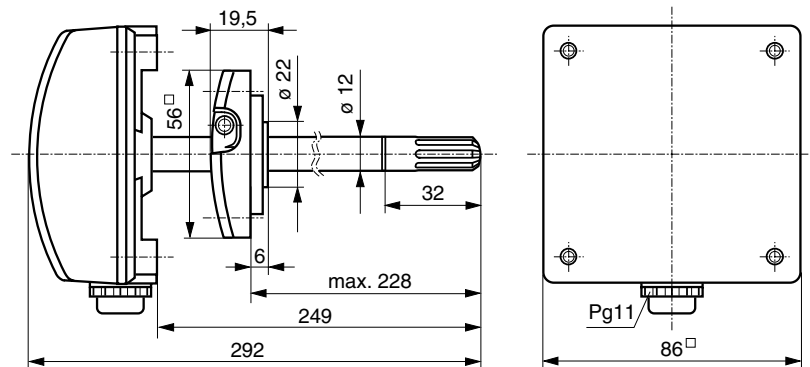

With mounting flange

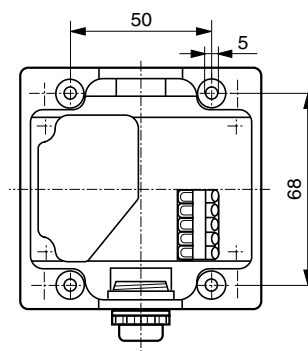

Without mounting flange

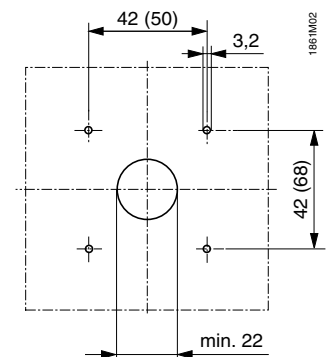

Fixing holes with (without) mounting flange