

# Electropneumatic Positioner Type 4763

## Pneumatic Positioner Type 4765



### Application

Single-acting positioner for attachment to pneumatic control valves. Supplied with either an electric input signal from 4(0) to 20 mA or 1 to 5 mA (Type 4763) or a pneumatic input signal from 0.2 to 1 bar (3 to 15 psi) (Type 4765).

**Rated travels from 7.5 to 90 mm**



The positioners ensure a predetermined assignment of the valve stem position (controlled variable  $x$ ) to the electric or pneumatic input signals (reference variable  $w$ ). They compare the input signal issued by the controller with the travel of the control valve and issue the corresponding output signal pressure  $p_{st}$  (output variable  $y$ ).

### Special features

- Compact, low-maintenance design
- Any mounting position possible
- Insusceptible to mechanical vibrations
- Reversible operating direction
- Excellent dynamic behavior
- Suitable for normal or split-range operation
- Adjustable proportional band (P-band)
- Adjustable air output capacity
- Low air consumption
- Special versions for oxygen service

Attachment to valves with cast yokes or rod-type yokes according to IEC 60534-6.

Optionally available with two pressure gauges to monitor supply air and signal pressure. Stainless steel pressure gauge housing with connections either nickel-plated or made of stainless steel.

An existing Type 4765 Pneumatic Positioner can be upgraded into an electropneumatic positioner.

### Versions

**Type 4763-0** (Fig. 1) · Electropneumatic positioner, without explosion protection

**Type 4763-1** · Electropneumatic positioner for hazardous areas, input circuit  $\text{Ex II 2 G EEx ia IIC T6}$  according to ATEX

**Type 4763-8** · Electropneumatic positioner in EEx nA "non-sparking"

**Type 4765/6116** (Fig. 3) · Electropneumatic positioner with type of protection "Flameproof enclosure" EEx d with Type 6116 i/p Converter (Fig. 2; refer to T 6116 EN for approvals)

**Type 4765** (Fig. 1) · Pneumatic positioner reference variable 0.2 to 1 bar (3 to 15 psi)



Fig. 1 · Type 4763/Type 4765 Positioner



Fig. 2 · Type 6116 i/p Converter, opened housing



Fig. 3 · Type 4765/6116 Ex d Positioner attachment to NAMUR rib

## Principle of operation

The only difference between the Type 4765 Pneumatic Positioner and the Type 4763 Electropneumatic Positioner is the electropneumatic (i/p) converter unit in the electropneumatic positioner to convert the electric signal from the controller into a proportional pneumatic signal.

These positioners use a flapper-nozzle system which operates according to the force-balance principle. They can be applied for both normal and split-range operation.

## Operating direction

When the reference variable ( $p_e$ ) increases, the output signal pressure  $p_{st}$  can be selected to be increasing-increasing (direct action >>) or increasing-decreasing (reverse action <<). The operating direction depends on the position of the nozzle assembly that can be turned by 180°. The visible marking (>> or <<) indicates which operating direction is effective. On changing the operating direction or the fail-safe position, note that the positioner must also be mounted in a different position (Figs. 5 to 8).

## Attachment according to IEC 60534-6 and NAMUR

The various ways in which the positioner can be attached to the actuator meet the requirements of IEC 60534-6 and NAMUR recommendation. Positioners may be attached to valves with either cast yokes (e.g. SAMSON Series 240) or rod-type yokes. Each type of attachment requires special mounting parts.

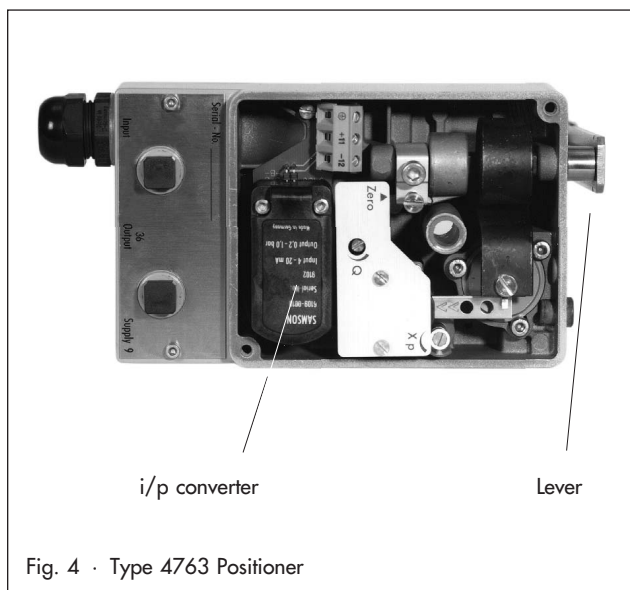

Fig. 4 · Type 4763 Positioner

## Assignment of the positioner and the actuator

Figs. 5 to 8 schematically illustrate the arrangement of the actuator, the mounting position of the positioner, the reference variable and the operating direction.

## Fail-safe action

The Type 3271 and Type 3277 Pneumatic Actuators are available with the following fail-safe actions:

### Actuator stem extends (Figs. 5 and 6)

Whenever the pressure acting on the diaphragm decreases or upon air supply failure, the compression springs in the actuator force the actuator stem to extend.

### Actuator stem retracts (Figs. 7 and 8)

Whenever the pressure acting on the diaphragm decreases or upon air supply failure, the compression springs in the actuator force the actuator stem to retract.

Refer to Data Sheets T 8310-1 EN and T 8310-2 EN for details.

Figs. 5 to 8 illustrate the different operating directions and the mounting positions of the positioner. Right and left attachment apply when looking onto the lever (1) and plate (2).

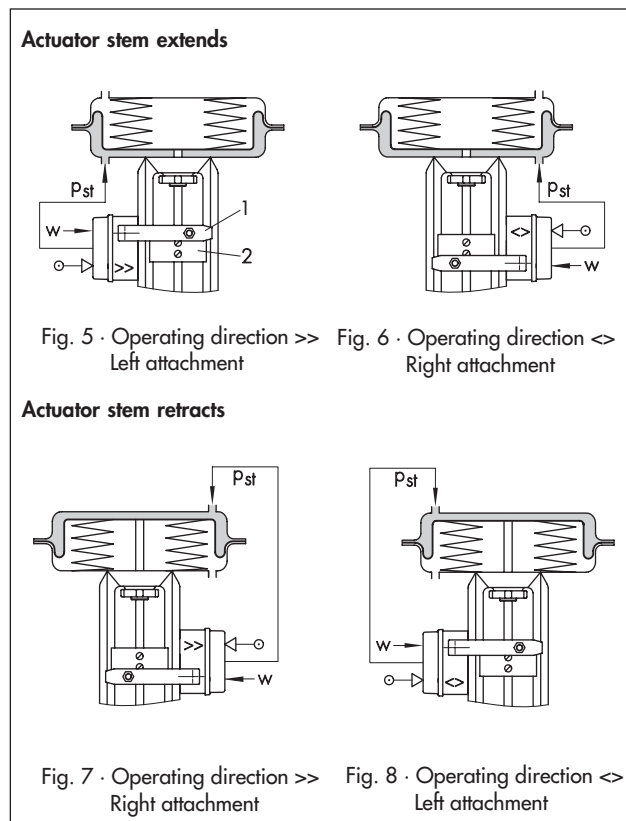

Table 1 · Technical data

Positioner	Type 4763	Type 4765
Travel range with lever extension	7.5 ... 60 mm 7.5 ... 90 mm	
Reference variable	4 ... 20 mA (only Ex) · $R_i \cong 250 \Omega \pm 7 \%$	0.2 ... 1 bar (3 ... 15 psi)
Span for split-range operation 0 to 50 % and 50 to 100 %	4 ... 20 mA (not Ex) · $R_i \cong 200 \Omega \pm 7 \%$	
( $R_i$ = Internal resistance at 20 °C)	0 ... 20 mA · $R_i \cong 200 \Omega \pm 7 \%$	
Supply air	Supply air	1.4 ... 6 bar (20 ... 90 psi)
	Air quality acc. to ISO 8573-1(2001)	Maximum particle size and density: Class 4 · Oil contents: Class 3 Pressure dew point: Class 3 or at least 10 K below the ambient temperature to be expected
Output signal pressure $p_{st}$		Max. 0 ... 6 bar

Positioner	Type 4763	Type 4765
Characteristic	Linear · Deviation from terminal-based conformity: < 1.5 %	
Hysteresis	< 0.5 %	
Sensitivity	< 0.1 %	
Operating direction	Reversible	
Proportional band $X_p$ (at 1.4 bar supply air)	Spring 1 or 2 Spring 3	1 ... 3 % 1 ... 1.5 %
Air consumption in steady state, $X_p = 1 %$	Supply air 1.4 bar 6 bar	0.19 $m_n^3/h$ 0.5 $m_n^3/h$
Air output capacity at $\Delta p$	1.4 bar 6 bar	3 $m_n^3/h$ 8.5 $m_n^3/h$
Transit time for Type 3271 "Stem extends"	240 $cm^2$ : $\leq 1.8 s$ · 350 $cm^2$ : $\leq 2.5 s$ · 700 $cm^2$ : $\leq 10 s$	
Permissible ambient temperature	With i/p Converter Type 6109      Type 6112 -20 ... 70 °C; With metal cable gland: -35 ... 70 °C -20 ... 80 °C; With metal cable gland: -35 ... 80 °C; Special version: -45 ... 80 °C -35 ... 80 °C; Special version: -50 ... 80 °C Version with oxygen as operating medium up to max. 60 °C	
Influence ( $X_p = 1 %$ )	Temperature < 0.03 %/°C · Supply air < 0.3 %/0.1 bar	
Effect of vibration	< 2 % between 10 ... 150 Hz and 1.5 g	-
Variable position when turned by 180°	< 3.5 %	-
Degree of protection	IP 54 · Special version IP 65	
Weight	Approx. 1.2 kg	1.1 kg
Materials	Die-cast aluminum	
Housing	Stainless steel 1.4571 and 1.4301	
External parts	Silicone	

**Table 3 · Assignment of lever and range spring**

Lever	Rated travel	Travel min./max.	Reference variable (input signal)	Range spring
Lever length L 40...127 mm	15 mm	7.5 ... 15 mm	100 % 50 %	1 2
	30 mm	14 ... 32 mm	100 % 50 %	2 3
	60 mm	30 ... 70 mm	100 %	3
Lever length L with extension 40...200 mm	20 mm	7.5 ... 26 mm	100 % 50 %	1 2
	40 mm	14 ... 50 mm	100 % 50 %	2 3
	>60 mm	30 ... 90 mm	100 %	3

## Summary of explosion-protection approvals for Type 4763

Type of approval	Certificate number	Date	Type of protection / Comments
EC Type Examination Certificate	PTB 02 ATEX 2078	2002-07-19	II 2 G EEx ia IIC T6; Type 4763-1
Statement of Conformity	PTB 03 ATEX 2183 X	2003-09-30	II 3 G EEx nA II T6, Zone 2; Type 4763-8
GOST approval	PPC 00-19324	2006-01-18	1 Ex ia IIC T6 X, valid until 2009-01-18; Type 4763-1
CSA approval	1607873	2005-09-16	Ex ia IIC T6; Class I, Zone 0 Class I, Div. 1, Groups A, B, C, D Class II, Div. 1, Groups E, F, G; Class III; Type 4763-3
FM approval	3020228	2005-02-28	Class I, II, III; Div. 1, Groups A, B, C, D, E, F, G Class I; Zone 0 AEx ia IIC T6 Class I; Div. 2, Groups A, B, C, D Class II; Div. 2, Groups F, G; Class III; NEMA 3R; with Types 6109 and 6112 i/p Module; Type 4763-3
KOSHA	2005-2333-Q-1	2005-11-14	Ex ia IIC T6, valid until 2010-11-13; Type 4763-1

### Approval for Type 4763 and Type 4765

AIR LIQUIDE	2003/OL 216 A	2003-07-30	Oxygen as the operating medium with Type 6109 i/p Converter Max. permissible ambient temperature 60 °C
-------------	---------------	------------	---

Refer to Data Sheet T 6116 EN for the EEx d approvals of Type 6116 i/p Converter

### Electrical connection and dimensions in mm

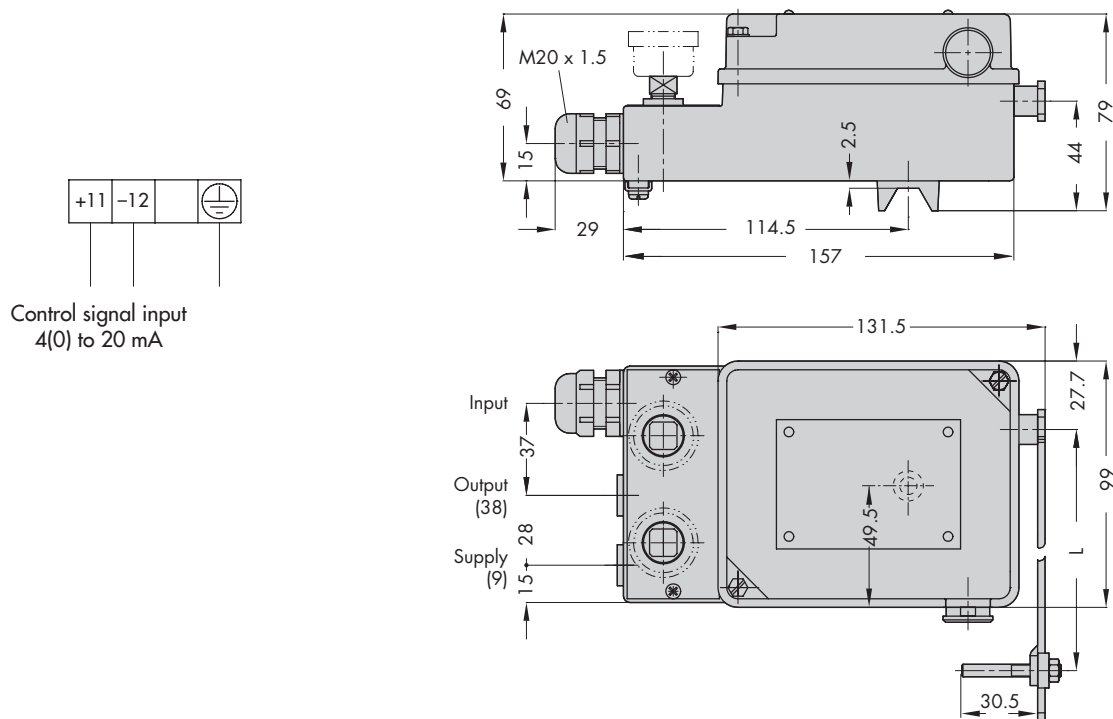

**Article code**

Electropneumatic Positioner	Type 4763-	x	1	x	0	0	x	x	x	x	0	x	0	x	x	0
<b>Explosion protection</b>																
Without	0								2/7							
⊕ II 2 G EEx ia IIC T6 acc. to ATEX	1															
CSA/FM intrinsically safe/non incandive	3															
⊕ II 3 G EEx nA II T6 for Zone 2 acc. to ATEX	8								2/7							
<b>Range spring</b>																
Range spring 1, travel = 15 mm			1													
Range spring 2, travel = 30 mm, split-range 15 mm			2													
Range spring 3, travel = 60 mm, split-range 30 mm			3													
<b>Pneumatic connections</b>																
ISO 228/1 G ¼							1									
¼-18 NPT							3									
<b>Electrical connection</b>																
<b>Cable gland</b>																
M20 x 1.5 blue (plastic)								1								
M20 x 1.5 black (plastic)								2								
M20 x 1.5 (nickel-plated brass)								7			2					
<b>i/p module</b>																
Type 6109									1							
Type 6112									2							
<b>Reference variable</b>																
4 ... 20 mA											0					
0 ... 20 mA									2	2						
1 ... 5 mA									2	3						
<b>Temperature range</b>																
Standard												0				
Low temperature down to -45 °C									2		2					
<b>Special version</b>																
None													0	0	0	
For oxygen as the operating medium	0/1												0	1	6	
⊕ II 3 D IP 54 T 80 °C (with manufacturer's declaration)	8								2/7				0	1	8	

## Article code

Pneumatic Positioner	Type 4765-	0	1	x	0	0	x	1	x	x	x	x	0
Range spring													
Range spring 1, travel = 15 mm				1									
Range spring 2, travel = 30 mm, split-range 15 mm				2									
Range spring 3, travel = 60 mm, split-range 30 mm				3									
Pneumatic connections													
ISO 228/1 - G 1/4							1						
1/4-18 NPT							3						
Temperature range													
Standard								0					
Low temperature down to -50 °C								1					
Special version													
None										0	0	0	
For oxygen as the operating medium										0	0	1	

## Ordering text

Electropneumatic Positioner Type 4763-x...

or

Pneumatic Positioner Type 4765-01...

## Additional specifications

- Without/with pressure gauge
- CrNiMo steel pressure gauge housing, connection nickel-plated or completely of CrNiMo steel for mounting onto control valve
- Reference variable adjusted ... or supply pressure ... bar
- Operating direction: Increasing-increasing or increasing-decreasing
- Piping: Zinc-plated steel or completely of CrNiMo steel or natural PE tubing DN 6/10
- Attachment acc. to IEC 60534-6 (NAMUR)  
Travel: ... mm, if applicable, rod diameter: ...mm
- Optionally, special version
- Extended temperature range
- Special version with oxygen as the operating medium

Refer to the Mounting and Operating Instructions EB 8359-1 EN (for Type 4765) or EB 8359-2 EN (for Type 4763) concerning the mounting parts required when the positioner is delivered unattached to a control valve.

Specifications subject to change without notice



SAMSON AG · MESS- UND REGELTECHNIK  
Weismüllerstraße 3 · 60314 Frankfurt am Main · Germany  
Phone: +49 69 4009-0 · Fax: +49 69 4009-1507  
Internet: <http://www.samson.de>

**T 8359 EN**

2008-04