

Electropneumatic Positioner and Pneumatic Positioner Type 3760



Application

Single-acting positioners for direct attachment to pneumatic control valves. Supplied with an electric input signal of 4 to 20 mA or a pneumatic input signal of 0.2 to 1 bar (3 to 15 psi).

For travels from 5 to 15 mm



JIS

The positioners ensure a predetermined assignment of the valve stem position (controlled variable x) to the control signal (reference variable w). They compare the control signal issued by a controller with the travel of the control valve and issue an output signal pressure p_{st} (output variable y).

The positioners have the following special features: suitable for normal and split-range operation; reversible operating direction; excellent dynamic response; low supply air consumption, insensitive to mechanical vibration; compact, low-maintenance design; optionally available with inductive limit switch and, on request, output pressure limiter.

A version for hazardous areas with type of protection "Intrinsic safety" Ex II 2 G EEx ia IIC T6 according to ATEX is available for the proximity switch circuit and for the signal circuit of the electropneumatic positioner (see summary of explosion protection certificates).

Type of protection EEx d with Type 6116 i/p Converter (Fig. 2)

Direct attachment to Type 3277 Pneumatic Actuators with effective areas of 120, 240 and 350 cm² (see T 8310-1 EN).

Optionally available with a pressure gauge (scale 0 to 6 bar and 0 to 90 psi) to monitor the signal pressure. The pressure gauge housing is made of stainless steel; connection optionally nickel-plated or completely of stainless steel.

Versions

Type 3760 Electropneumatic Positioner (Fig. 1)

Version suitable for non-hazardous areas. Signal pressure ranges from 0 to 6 bar (0 to 90 psi); supply air from 1.4 to 6 bar (20 to 90 psi). Reference variable: standard version 4 to 20 mA.

Type 3760 Electropneumatic Positioner

Same version as above, except for its use in hazardous areas.

Type of protection Ex II 2 G EEx ia IIC T6 for the signal circuit

Type of protection EEx d with Type 6116 i/p Converter (Fig. 2)

On request, also available with an intrinsically safe inductive limit switch.

Type 3760 Pneumatic Positioner

Reference variable 0.2 to 1 bar (3 to 15 psi), signal pressure ranges from 0.2 to approx. 6 bar (3 to approx. 90 psi); supply air from 1.4 to 6 bar (20 to 90 psi). On request, also available with an intrinsically safe inductive limit switch.

The article codes contain detailed ordering information.



Fig. 1 · Type 3760 Positioner

Fig. 2 · Micro-flow control valve with EEx d positioner
(Type 3760 with Type 6116 i/p Converter)

Principle of operation

The only difference between the positioners is that the electro-pneumatic positioner is equipped with an i/p converter (2).

Both positioners ensure a predetermined assignment of the valve stem position to the control signal. The controlled variable x is the valve travel. The reference variable w is either a DC signal (i) for the electropneumatic positioner (i/p) or a pneumatic signal (p_e) for the pneumatic positioner (p/p). The DC signal and the pneumatic signal are both issued by a connected controller. The manipulated variable y is the positioner's output pressure (p_{st}).

The Type 3760 Positioners are designed for direct attachment to SAMSON Type 3277 Actuators.

In the electropneumatic positioner, the direct current signal i is transmitted from the controller to the i/p converter (2), where it is converted into a proportional air pressure p_e of 0.2 to 1 bar or 3 to 15 psi.

In the pneumatic positioner, the control signal p_e provided as air pressure is directly transmitted to the measuring diaphragm (3).

The pneumatic control signal p_e produces a force at the measuring diaphragm (3) which is compared to the force of the range spring (7). The motion of the measuring diaphragm (3) is transmitted to the double plug (13) of the force switch (12) via the lever (4). As a result, a corresponding signal pressure p_{st} is produced. Any changes in the control signal p_e or the valve stem position causes changes in the signal pressure p_{st} . Thus, the plug stem of the valve moves to the position which corresponds to the reference variable.

The positioners can be used for both standard and split-range operation. Note that the signal pressure range (range of the output pressure p_{st}) must match the spring range of the actuator.

In split-range operation, the output signal of a control station intended to control two control valves is divided in such a way that each actuator passes through its full travel at half the input span. For a span between 0.2 and 1 bar, for example, the first valve is adjusted to the first half (from 0.2 to 0.6 bar), the second is adjusted to the second half (from 0.6 to 1 bar).

The adjustment screws for zero (5) and span (8) are used to set the lower and upper range values of the input signal. The range spring (7) must be chosen to match both the rated travel of the control valve and the nominal span of the reference variable.

Operating direction

When the pneumatic control signal p_e (reference variable) increases, the signal pressure p_{st} can be selected to be increasing (direct action >>) or decreasing (reverse action <>). The operating direction is determined by the position of the force switch (12) and can also be changed on site.

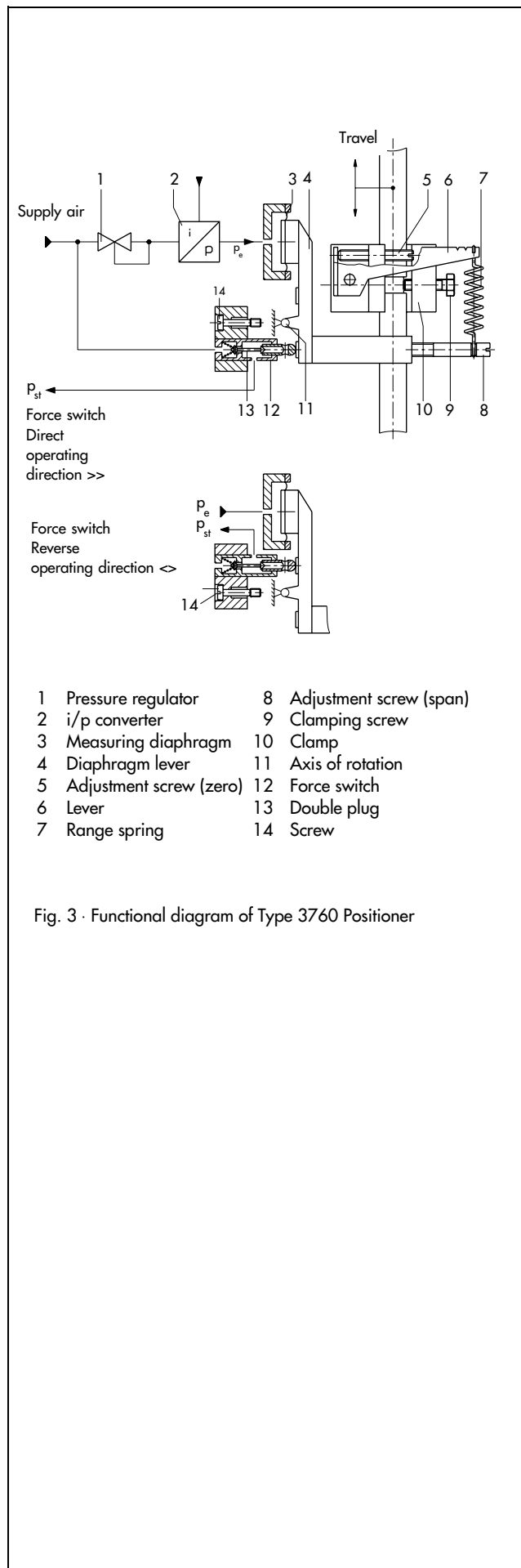

Fig. 3 · Functional diagram of Type 3760 Positioner

Table 1 · Technical data

Travel range		5 to 15 mm (see Table 2 for range springs)
Reference variable	Pneumatic	0.2 to 1 bar (3 to 15 psi)
Span for split-range operation 0 to 50 % or 50 to 100 % (R _i = internal resistance at 20 °C)	Electric	4 to 20 mA (only Ex) · R _i ≅ 250 Ω ± 7 %
		4 to 20 mA (non-Ex) · R _i ≅ 200 Ω ± 7 %
		0 to 20 mA · R _i ≅ 200 Ω ± 7 %
		1 to 5 mA · R _i ≅ 880 Ω ± 7 %
Supply air		1.4 to 6 bar (20 to 90 psi)
Air quality acc. to ISO 8573-1 (2001)		Maximum particle size and density: Class 4 · Oil contents: Class 3 Pressure dew point: Class 3 or at least 10 K below the lowest expected ambient temperature
Output signal pressure p _{st}		Max. 0 to 6 bar (0 to 90 psi)
Characteristic		Linear; deviation from terminal-based conformity ≤ 1.5 %
Hysteresis		≤ 0.5 %
Sensitivity		< 0.1 %
Operating direction		Reversible
Air consumption in steady state		At 0.6 bar signal pressure and supply air pressure up to 6 bar ≤ 100 l _n /h
Air output capacity		At Δp = 1.4 bar 1600 l _n /h · At Δp = 6 bar 5000 l _n /h
Transit times with Type 3277 Actuator (15 mm travel, 0.2 to 1 bar signal pressure)		120 cm ² ≤ 2s · 240 cm ² ≤ 6s · 350 cm ² ≤ 8s
Permissible ambient temperature		-20 to +70 °C · Wider temperature range on request
(Note the limits specified in the EC Type Examination Certificate)		Down to -30 °C with metal cable gland Down to -40 °C with metal cable gland and Type 6112 i/p Converter The limits of the EC Type Examination Certificate additionally apply for explosion-protected devices. -40 to 70 °C with Type 3760 used as pneumatic positioner without proximity switch
Influence	Temp. zero point	≤ 0.03 %/°C
	Span	≤ 0.03 %/°C
	Vibration	Between 5 and 120 Hz and 2 g ≤ 0.5 %
	Supply air	≤ 1 % between 1.4 and 6 bar
Variable position when turned 180°		< 3.5 %
Degree of protection		IP 54 (IP 65 special version)
Weight		0.6 kg
Accessories		
Inductive limit switch (proximity switch)		Type SJ2-SN
Control circuit		Values corresponding to the downstream transistor relay
Hysteresis at rated travel		≤ 1 %

Table 2 · Range springs

Range spring	Reference variable (%)	Travel (mm)
1	0 to 100 Split-range 0 to 50 or 50 to 100	12/15 6/7.5
2	0 to 100	6/7.5
3	Split-range 0 to 50	12/15
4	Split-range 50 to 100	12/15
5	0 to 100	5
6	0 to 100	20
7	Split-range 0 to 50 or 50 to 100	5

Positioner attachment

The positioners are designed for direct attachment to Type 3277 Actuators with effective areas 350 cm² and smaller. They are secured directly to the actuator yoke using two screws.

No external piping is necessary for actuators with effective areas of 120 cm². The signal pressure p_{st} from the positioner is transmitted to the desired diaphragm chamber via a switchover plate and internal air ducts.

Combination of positioner and actuator

Fig. 4 illustrates the different types of attachment. The specifications "left attachment" or "right attachment" apply when looking onto the switchover plate and the signal pressure connection. Depending on the intended attachment, the positioner is to be secured on either the right or the left side of the yoke.

Subsequent conversion, such as reversing the operating direction of the positioner control loop or modifying the actuator's fail-safe action, is possible. In this case, note that the positioner must also be attached in a different position.

Fail-safe action

The Type 3277 Pneumatic Actuator has the two fail-safe actions which move the valve stem to the predetermined position whenever the signal pressure decreases or the air supply fails.

Actuator stem extends

Whenever the pressure acting on the surface of the diaphragm decreases or the air supply fails, the force of the compression springs in the actuator causes the actuator stem to extend.

Actuator stem retracts

Whenever the pressure acting on the surface of the diaphragm decreases or the air supply fails, the force of the compression springs in the actuator causes the actuator stem to retract.

Further details can be found in Data Sheet T 8310-1 EN.

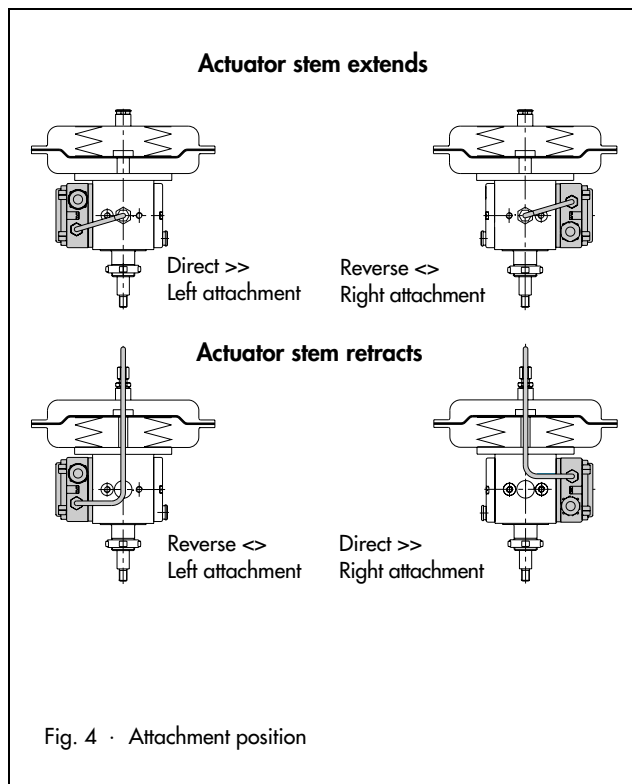

Fig. 4 · Attachment position

Summary of explosion protection approvals for Type 3760 Positioner

Type of approval	Certificate number	Date	Comments
EC Type Examination Certificate	PTB 02 ATEX 2076	2002-07-18	⊕ II 2 G EEx ia IIC T ₆ ; Inductive limit switches PTB 99 ATEX 2219 X; Type 3760-1
Statement of Conformity	PTB 03 ATEX 2181 X	2003-09-30	⊕ II 3 G EEx nA IIC T ₆ ; Zone 2; Type 3760-8
CSA approval	LR 54227-23	1996-04-22	Class 1, Div. 1; Groups A, B, C, D NLRC approval also valid in the USA
	LR 54227-32	1999-10-14	Encl. 3; inductive limit switches; Type 3760-3
FMRC approval	J.I. 3020228	2005-02-28	Classes I, II, III Div. 1, Groups A, B, C, D, E, F, G Class I, Zone 0 AEx ia IIC T ₆ ; Class I; Div. 2; Groups A, B, C, D Class II; Div. 2; Groups F, G; Class III
	Revision		NEMA 3R with inductive limit switches; Type 6109 and Type 6112 i/p Module; Type 3760-3
JIS approval (Japan) First extension	C 13476	August 1996	Ex ia IIC T ₆ ; with Type 6112 i/p Module
	C13362	Feb. 2002 Sept. 1998	Ex ia IIC T ₆ ; valid until 2005-02-21 Ex ia IIC T ₆ ; with Type 6109 i/p Module; Type 3760-7

Refer to Data Sheet T 6116 EN for EEx d certificates for Type 6116 i/p Converter.

Materials

Housing	Polyamide
External parts	Stainless steel 1.4571 and 1.4104
Meas. diaphragm	Fluorosilicone rubber
Cable gland	Polyamide, M20 x 1.5

Electrical connections

Pneumatic version

Limit switch

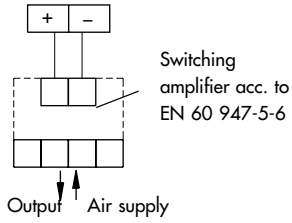

Electropneumatic version

With mA control signal

Limit switch

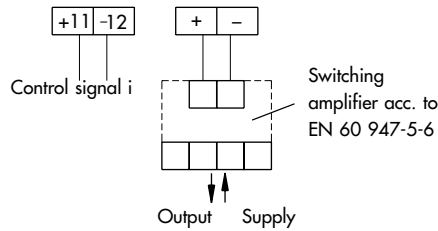

DIN connector
(DIN 43 650)

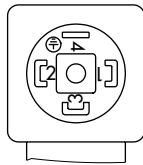

Connection	Terminal
1	+ 11 i/p converter
2	- 12
3	+ Limit switch
4	-

Dimensions in mm

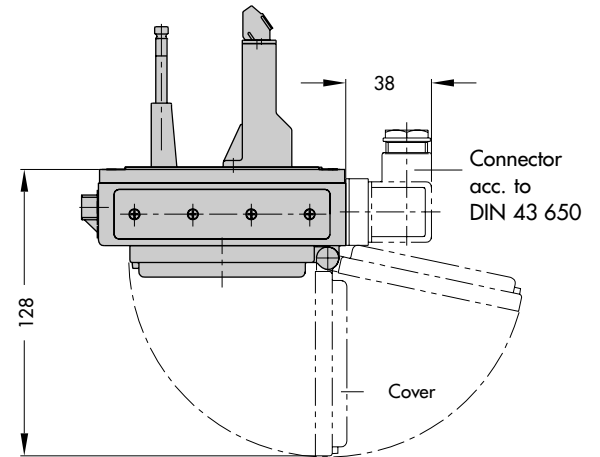
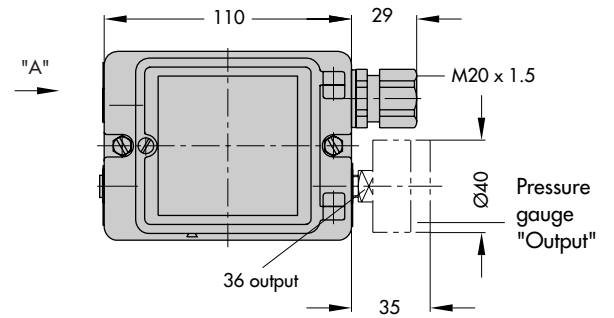

View in direction "A"

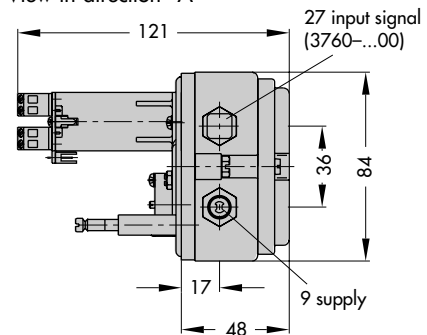

Pneumatic connections G 1/8 or 1/8 NPT

Article code

Positioner	Type 3760-	x	x	x	x	x	x	0	0	0	0	0	0
Explosion protection													
Without		0				2/3							
⊕ II 2 G EEx ia IIC T6 acc. to ATEX		1				0							
FM/CSA intrinsically safe/non incandive		3				0							
Australia Ex (Zone 0 and Zone 2)		6				0							
JIS Japan		7				0							
⊕ II 3 G EEx nA II T6 acc. to ATEX		8				0							
Limit switches													
Without			0										
1 x inductive, SJ2-SN			1										
Pneumatic connections													
ISO 228/1 - G 1/8					1								
1/8 - 27 NPT					2								
Electrical connection													
Without						0	0	0					
Cable gland M20 x 1.5, blue (plastic)						1							
Cable gland M20 x 1.5, black (plastic)						2							
Connector DIN 43650-AF3-PG11						3							
i/p module													
Without							0	0					
Type 6109							1	1					
Type 6112							2	1/2/3					
Reference variable													
0.2 ... 1.0 bar / 3 ... 15 psi									0				
4 ... 20 mA									1				
0 ... 20 mA									2				
1 ... 5 mA									3				

Accessories

Adapter 1/2 NPT for electrical connections

Additional specifications

Range spring 1/ ... 7/
 Pressure gauge Without/with
 Gauge housing CrNiMo steel,
 Connection optionally nickel-plated/completely CrNiMo steel

Specifications subject to change without notice.



SAMSON AG · MESS- UND REGELTECHNIK
 Weismüllerstraße 3 · 60314 Frankfurt am Main · Germany
 Phone: +49 69 4009-0 · Fax: +49 69 4009-1507
 Internet: <http://www.samson.de>

T 8385 EN