



AUTOCLUDE[®]

PERISTALTIC PUMPS

MODEL: M500 a.c.

Robust pump with proven track record for a variety of applications including vending, chemical dosing and condensate removal. Flow rates up to 730 ml/min

Pump head: Polycarbonate - standard
Noryl - optional

Motor: Asynchronous shaded pole motor with spur gearbox

Rotor: 2 Roller Polycarbonate

Options: 3 Roller Rotor
Different motor stack sizes for varied torque applications: - 3/4", 1", 1 1/2"

Power Supply: 110, 220, 240v 50/60 Hz

Tube: Silicone, Autoprene, Tygon, Viton and Prothane 1.6mm, 3.2mm & 4.8mm

Weight: 1.5Kg

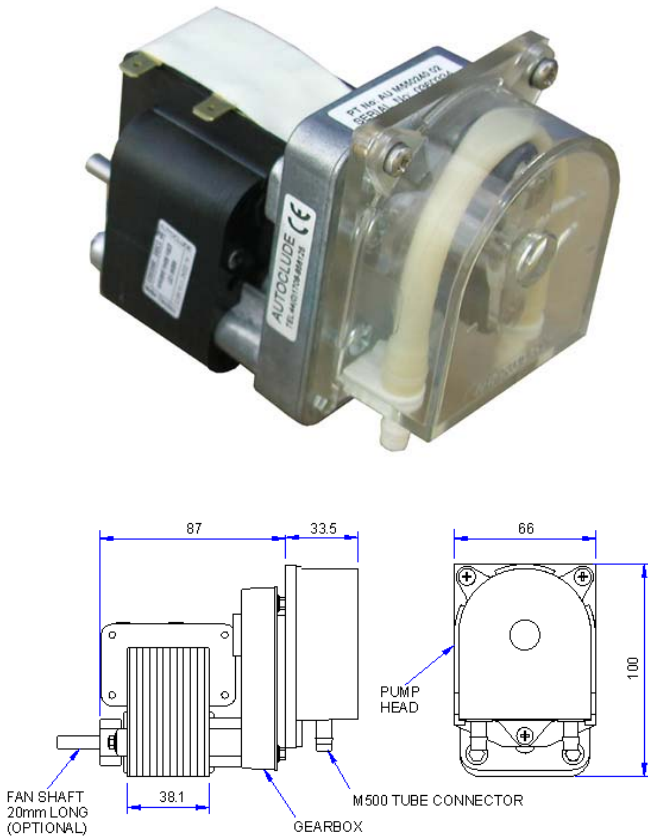

FLOW RATES ml/min							
TUBE	30 RPM	51 RPM	82 RPM	125 RPM	176 RPM	240 RPM	325 RPM
1.6 mm	8.40 ml/min	14.28 ml/min	22.96 ml/min	35.00 ml/min	49.28 ml/min	67.20 ml/min	91.00 ml/min
3.2 mm	30.00 ml/min	51.00 ml/min	82.00 ml/min	125.00 ml/min	176.00 ml/min	240.00 ml/min	325.00 ml/min
4.8 mm	67.50 ml/min	114.75 ml/min	184.50 ml/min	281.25 ml/min	396.00 ml/min	540.00 ml/min	731.25 ml/min

Identify required flow rate in above table and select largest tube size with slowest motor speed to achieve best tube life.

AUTOCLUDE LTD
 Arisdale Avenue, South Ockendon, Essex, RM15 5DP, U.K.
 Tel: +44(0)1708 856125 Fax: +44(0)1708 857366
 Email: 'info@autocldepumps.com'
 Website: 'www.autocldeumpns.com'