

Free of maintenance stop valve with bellows seal - metallic sealing

ARI-FABA® LongLife -

Straight through with flanges

- DIN DVGW-Type approval
- Test approvals TÜ.A/TÜV.AR.186-00
- German TA - Luft TÜV-Test-No. 088-945053
- TRB 801 Annex II No. 45 (except EN-JL1040)

Grey cast iron
SG iron
Cast steel
Forged steel

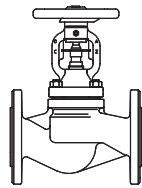

Fig. 046 Page 2+3

ARI-FABA® LongLife -

Straight through with butt weld ends

- DIN DVGW-Type approval
- Test approvals TÜ.A/TÜV.AR.186-00
- German TA - Luft TÜV-Test-No. 088-945053
- TRB 801 Annex II No. 45

Forged steel

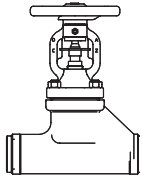

Fig. 040 Page 4

ARI-FABA® LongLife -

Straight through with butt weld ends

- DIN DVGW-Type approval
- Test approvals TÜ.A/TÜV.AR.186-00
- German TA - Luft TÜV-Test-No. 088-945053
- TRB 801 Annex II No. 45

Cast steel

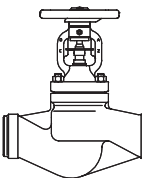

Fig. 040 Page 5

ARI-FABA® LongLife -

Y-pattern with butt weld ends

- DIN DVGW-Type approval
- Test approvals TÜ.A/TÜV.AR.186-00
- German TA - Luft TÜV-Test-No. 088-945053
- TRB 801 Annex II No. 45

Cast steel

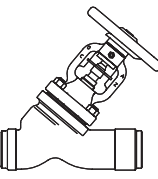

Fig. 066 Page 6

ARI-FABA® LongLife -

Angle pattern with flanges

- DIN DVGW-Type approval
- Test approvals TÜ.A/TÜV.AR.186-00
- German TA - Luft TÜV-Test-No. 088-945053
- TRB 801 Annex II No. 45 (except EN-JL1040)

Grey cast iron
SG iron
Cast steel

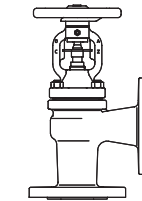

Fig. 047 Page 7

ARI-FABA® LA -

Straight through with flanges

- German TA - Luft TÜV-Test-No. 088-945053
- TRB 801 Annex II No. 45

Cast steel

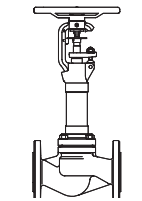

Fig. 044 Page 8

ARI-FABA® LA -

Straight through with butt weld ends

- German TA - Luft TÜV-Test-No. 088-945053
- TRB 801 Annex II No. 45

Cast steel
Forged steel

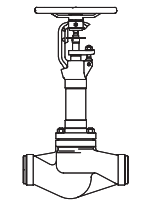

Fig. 067 Page 9+10

ARI-FABA® LA -

Y-pattern with butt weld ends

- German TA - Luft TÜV-Test-No. 088-945053
- TRB 801 Annex II No. 45

Cast steel

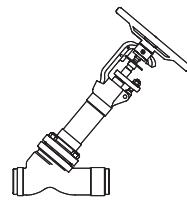

Fig. 068 Page 11

FABA®
LONG LIFE

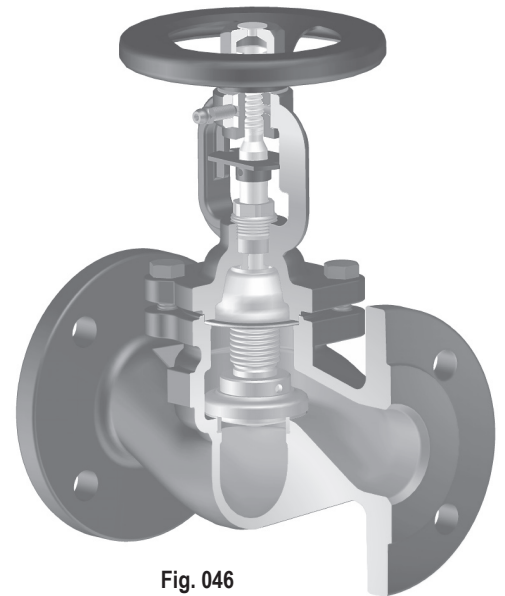

Fig. 046

For stainless steel versions
refer to data sheet „ARI-FABA® LongLife Stainless steel“
For ANSI versions
refer to data sheet „ARI-FABA®-ANSI LongLife“

Features:

- Two-ply bellows seal as standard
- DN 15-100 throttling plug as standard
- DN 15- 80 stem with fine thread as standard
- Lubricating nipple as locking device as standard
- Cast iron variations with nodular iron bonnet as standard
- Heat dissipating bonnet
- Stem with bellows seal
- Secondary sealing: gland packing
- Position indicator as standard
- Non-rising handwheel
- Non-rotation lock for each nominal diameter
- External stem thread
- Stem with roll hardened thread

ARI-FABA®LA:

- Bellows seal out of media flow path
- Favourable zeta-values also for small nominal diameters
- Gland packing sleeve with pivot mounted bolts

Stop valve - straight through with flanges and bellows seal (Grey cast iron, SG iron, Cast steel)

Figure-No.	Nominal pressure	Material	Nominal diameter
12.046	PN16	EN-JL1040	DN15-300
22.046	PN16	EN-JS1049	DN15-350
	Test: DIN DVGW-Reg. DG-4313AO 0772		
23.046	PN25	EN-JS1049	DN15-150
34.046	PN25	1.0619+N	DN200-400
	Test: Test approvals TÜ.A/TÜV.AR.186-00 DIN DVGW-Reg. DG-4313AO 0777		
35.046	PN40	1.0619+N	DN15-250
	Test: Test approvals TÜ.A/TÜV.AR.186-00 DIN DVGW-Reg. DG-4313AO 0777		
Test: • German TA - Luft TÜV-Test-No. 088-945053			
At high differential pressures a balancing plug is necessary! (refer to page 13)			
DN15-100: Throttling plug as standard (for max. permissible ΔP refer to: Flow diagram)			

Selection of possible applications

Industry, powerstations, flue gas purification plant, processing technology, gas supply, vapour facilities, recycling facilities, vacuum facilities, hot water, heating technology, district heating, thermal oil applications, general plant manufacturing, etc.
(other applications on request)

Selection of possible flow media

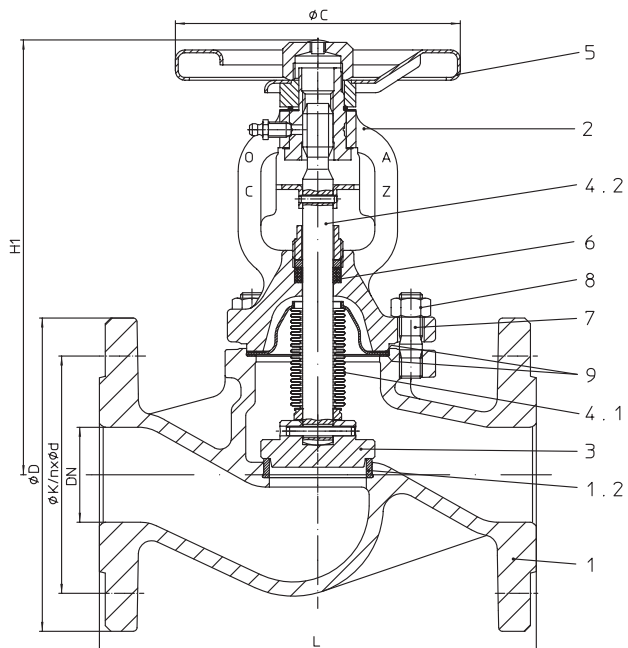
Steam, gases, hot water, thermal oil, process water, vacuum facilities, ammonia etc.
(other flow media on request)

Parts

Pos.	Description	Fig. 12.046	Fig. 22.046 / Fig. 23.046	Fig. 34.046 / Fig. 35.046
1	Body	EN-JL1040, EN-GJL-250	EN-JS1049, EN-GJS-400-18U-LT	GP240GH+N, 1.0619+N
1.2	Seat ring	X20Cr13+QT, 1.4021+QT	X20Cr13+QT, 1.4021+QT	≤DN50: X20Cr13+QT, 1.4021+QT / >DN50: G19 9 NbSi, 1.4551
2	Bonnet	EN-JS1049, EN-GJS-400-18U-LT	EN-JS1049, EN-GJS-400-18U-LT	≤ DN80: P250GH, 1.0460 > DN80: GP240GH+N, 1.0619+N
3	Plug *	≤ DN200: X20Cr13+QT, 1.4021+QT / > DN200: P265GH, 1.0425 / G19 9 Nb Si, 1.4551		
4.1	Bellows seal *	X6CrNiMoTi17 12 2, 1.4571		
4.2	Stem *	X20Cr13+QT, 1.4021+QT		
5	Handwheel	≤DN125: St (epoxy-coating) / >DN125: EN-JL1040, EN-GJL-250 (epoxy-coating)		
6	Packing ring *	Pure graphite		
7	Hexagon bolt	5.6	--	
7	Stud	--	25CrMo4, 1.7218	
8	Hexagon nut	--	C35E, 1.1181	
9	Gasket *	Pure graphite (CrNi laminated with graphite)		

* Spare part

Information / restriction of technical rules need to be observed!

Operating instructions can be ordered by phone +49 (0)5207 / 994-0 or fax +49 (0)5207 / 994-158 or -159.

ARI-Valves of EN-JL1040 are not allowed to be operated in systems acc. to TRD 110.

A production allowance acc. to TRB 801 No. 45 exists (acc. to TRB 801 No. 45 EN-JL1040 is not allowed.)

The engineer, designing a system or a plant, is responsible for the selection of the correct valve.

Dimensions

	DN	15	20	25	32	40	50	65	80	100	125	150	200	250	300	350	400
L	(mm)	130	150	160	180	200	230	290	310	350	400	480	600	730	850	980	1100
H1	(mm)	205	205	210	210	225	230	245	265	365	395	425	550	720	775	975	1015
ØC (PN16/25)	(mm)	126	126	126	126	150	150	175	175	225	300	400	520	520	520	640	640
ØC (PN40)	(mm)	126	126	126	126	150	150	175	225	300	300	400	520	520	--	--	--
Travel	(mm)	6	6	8	8	13	13	16	20	25	32	40	50	70	80	90	100
Kvs-value	(m ³ /h)	4,7	7,4	11,2	18,3	29,3	44,2	73,2	112,2	173	288	410	725	1145	1635	2220	3180
Zeta-value	--	3,7	4,7	5	5	4,8	5,1	5,3	5,2	5,3	4,7	4,8	4,9	4,8	4,8	4,9	4

Zeta-value ... range of tolerance for Kvs-values acc. to VDI/VE 2173

Standard-flange dimensions refer to page 15

Face-to-face dimension FTF series 1 according to DIN EN 558

Weights

Figure-No.	DN	15	20	25	32	40	50	65	80	100	125	150	200	250	300	350	400
12. / 22. / 23.046	(kg)	3,6	4,3	5,3	6,6	9,2	11,6	15,8	21,8	33	54	69	140	240	265	360	--
34.046	(kg)	--	--	--	--	--	--	--	--	--	--	--	147	238	339	570	650
35.046	(kg)	4,5	4,8	6,2	7,3	10,6	12,6	19,1	26,1	35	60,3	88	178	305	--	--	--

Stop valve - straight through with flanges and bellows seal (Forged steel)

Figure-No.	Nominal pressure	Material	Nominal diameter
45.046	PN40	1.0460	DN15-50
	DN >50 refer to Fig. 35.046 (1.0619+N)		
Test: • Test approvals TÜ.A/TÜV.AR.186-00 • German TA - Luft TÜV-Test-No. 088-945053			
Throttling plug as standard (for max. permissible ΔP refer to: Flow diagram)			

Selection of possible applications

Industry, powerstations, flue gas purification plant, processing technology, gas supply, vapour facilities, recycling facilities, vacuum facilities, hot water, heating technology, district heating, thermal oil applications, general plant manufacturing, etc.
 (other applications on request)

Selection of possible flow media

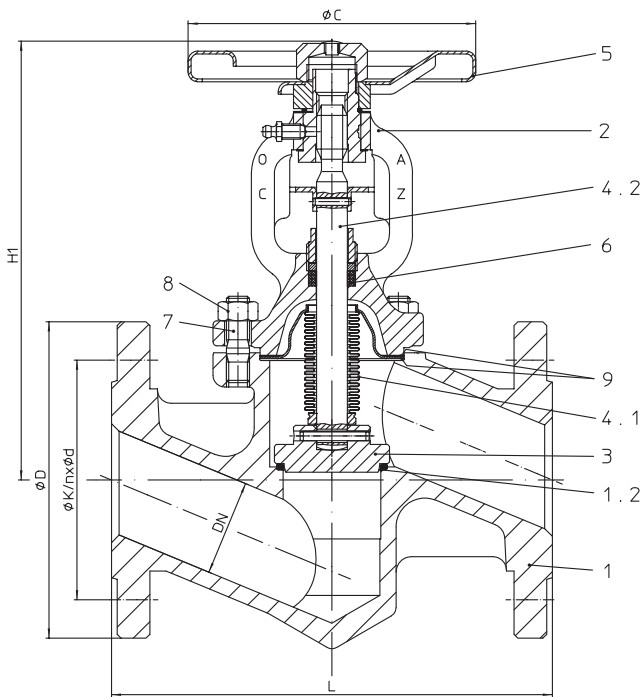
Steam, gases, hot water, thermal oil, process water, vacuum facilities, ammonia etc.
 (other flow media on request)

Parts

Pos.	Description	Fig. 45.046
1	Body	P250 GH, 1.0460
1.2	Seat	G19 9 NbSi, 1.4551
2	Bonnet	P250 GH, 1.0460
3	Plug *	X20Cr13+QT, 1.4021+QT
4.1	Bellows seal *	X6CrNiMoTi17 12 2, 1.4571
4.2	Stem *	X20Cr13+QT, 1.4021+QT
5	Handwheel	Fe P01, 1.0330 (epoxy-coating)
6	Packing ring *	Pure graphite
7	Stud	25CrMo4, 1.7218
8	Hexagon nut	C35E, 1.1181
9	Gasket *	Pure graphite (CrNi laminated with graphite)

* Spare part

Information / restriction of technical rules need to be observed!

Operating instructions can be ordered by phone +49 (0)5207 / 994-0 or fax +49 (0)5207 / 994-158 or -159.

A production allowance acc. to TRB 801 No. 45 exists.

The engineer, designing a system or a plant, is responsible for the selection of the correct valve.

Dimensions

	DN	15	20	25	32	40	50
L	(mm)	130	150	160	180	200	230
H1	(mm)	215	215	225	230	225	230
ØC (PN40)	(mm)	126	126	126	126	150	150
Travel	(mm)	6	6	8	8	13	13
Kvs-value	(m³/h)	3,3	5,8	9,2	15	23,3	36
Zeta-value	--	7,4	7,6	7,4	7,4	7,5	7,7

Zeta-value ... range of tolerance for Kvs-values acc. to VDI/VDE 2173

Standard-flange dimensions refer to page 15

Face-to-face dimension FTF series 1 according to DIN EN 558

Weights

Figure-No.	DN	15	20	25	32	40	50
45.046	(kg)	3,8	4,8	5,5	7	10	12

Stop valve - straight through with butt weld ends and bellows seal (Forged steel)

Figure-No.	Nominal pressure	Material	Nominal diameter
45.040	PN40	P250 GH	DN15-50
	DN >50 refer to Fig. 35.040 (1.0619+N)		
Butt weld ends according to DIN EN 12627 - 4 (refer to page 12)			
Test: • Test approvals TÜ.A/TÜV.AR.186-00 • German TA - Luft TÜV-Test-No. 088-945053			
Throttling plug as standard (for max. permissible ΔP refer to: Flow diagram)			

Selection of possible applications

Industry, powerstations, flue gas purification plant, processing technology, gas supply, vapour facilities, recycling facilities, vacuum facilities, hot water, heating technology, district heating, thermal oil applications, general plant manufacturing, etc.
(other applications on request)

Selection of possible flow media

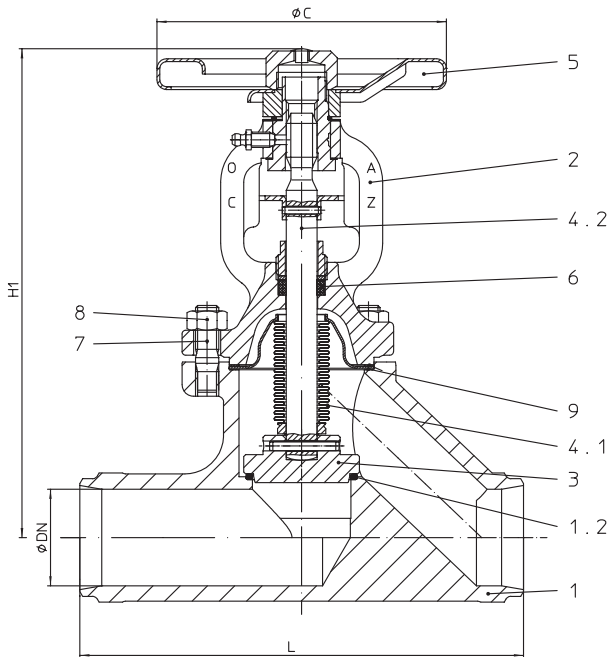
Steam, gases, hot water, thermal oil, process water, vacuum facilities, ammonia etc.
(other flow media on request)

Parts

Pos.	Description	Fig. 45.040
1	Body	P250 GH, 1.0460
1.2	Seat	G19 9 NbSi, 1.4551
2	Bonnet	P250 GH, 1.0460
3	Plug *	X20Cr13+QT, 1.4021+QT
4.1	Bellows seal *	X6CrNiMoTi17 12 2, 1.4571
4.2	Stem *	X20Cr13+QT, 1.4021+QT
5	Handwheel	Fe P01, 1.0330 (epoxy-coating)
6	Packing ring *	Pure graphite
7	Stud	25CrMo4, 1.7218
8	Hexagon nut	C35E, 1.1181
9	Gasket *	Pure graphite (CrNi laminated with graphite)

* Spare part

Information / restriction of technical rules need to be observed!

Operating instructions can be ordered by phone +49 (0)5207 / 994-0 or fax +49 (0)5207 / 994-158 or -159.

A production allowance acc. to TRB 801 No. 45 exists

The engineer, designing a system or a plant, is responsible for the selection of the correct valve.

Dimensions

	DN	15	20	25	32	40	50
L	(mm)	130	150	160	180	200	230
H1	(mm)	215	215	225	230	250	255
ØC (PN40)	(mm)	126	126	126	126	150	150
Travel	(mm)	6	6	8	8	13	13
Kvs-value	(m ³ /h)	3,3	5,8	9,2	15	23,3	36
Zeta-value	--	7,4	7,6	7,4	7,4	7,5	7,7

Zeta-value ... range of tolerance for Kvs-values acc. to VDI/VDE 2173

Face-to-face dimension ETE series 1 according to DIN EN 12982

Weights

Figure-No.	DN	15	20	25	32	40	50
45.040	(kg)	2,6	2,8	3,8	4,2	5,8	8,2

Stop valve - straight through with butt weld ends and bellows seal (Cast steel)

Figure-No.	Nominal pressure	Material	Nominal diameter
34.040	PN25	1.0619+N	DN200-300
35.040	PN40	1.0619+N	DN65-250
Butt weld ends according to DIN EN 12627 - 4 (refer to page 12) alternative: DN 65-200 with shoed ends of P235GH			
Test: • Test approvals TÜ.A/TÜV.AR.186-00 • German TA - Luft TÜV-Test-No. 088-945053 • DIN DVGW-Reg. DG-4313AO 0777 / 0778			
At high differential pressures a balancing plug is necessary! (refer to page 13)			
DN65-100: Throttling plug as standard (for max. permissible ΔP refer to: Flow diagram)			

Selection of possible applications

Industry, powerstations, flue gas purification plant, processing technology, gas supply, vapour facilities, recycling facilities, vacuum facilities, hot water, heating technology, district heating, thermal oil applications, general plant manufacturing, etc.
(other applications on request)

Selection of possible flow media

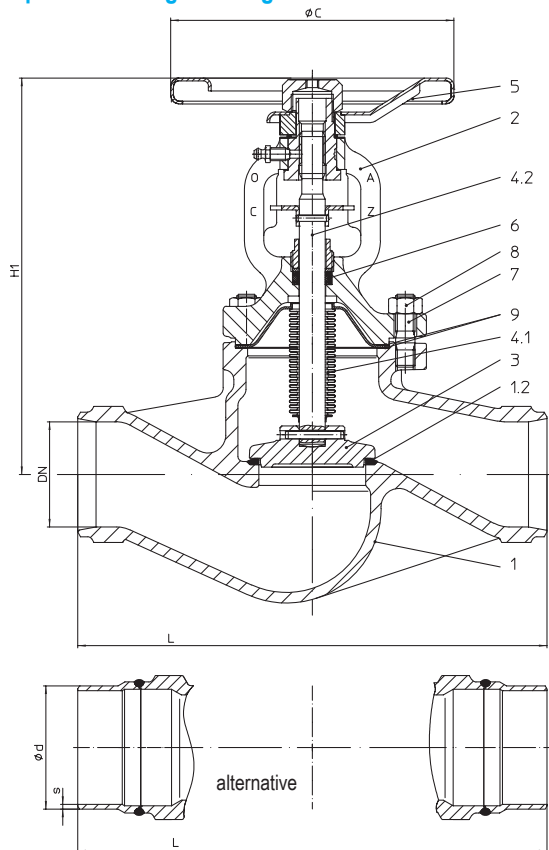
Steam, gases, hot water, thermal oil, process water, vacuum facilities, ammonia etc.
(other flow media on request)

Parts

Pos.	Description	Fig. 34.040 / 35.040
1	Body	GP240GH+N, 1.0619+N
1.2	Seat	G19 9 NbSi, 1.4551
2	Bonnet	≤ DN80: P250GH, 1.0460 / > DN80: GP240GH+N, 1.0619+N
3	Plug *	≤DN200: X20Cr13+QT, 1.4021+QT / >DN200: P265GH, 1.0425 / G19 9 Nb Si, 1.4551
4.1	Bellows seal *	X6CrNiMoTi17 12 2, 1.4571
4.2	Stem *	X20Cr13+QT, 1.4021+QT
5	Handwheel	≤DN125: St (epoxy-coating) / >DN125: EN-JL1040, EN-GJL-250 (epoxy-coating)
6	Packing ring *	Pure graphite
7	Stud	25CrMo4, 1.7218
8	Hexagon nut	C35E, 1.1181
9	Gasket *	Pure graphite (CrNi laminated with graphite)
* Spare part		

Information / restriction of technical rules need to be observed!

Operating instructions can be ordered by phone +49 (0)5207 / 994-0 or fax +49 (0)5207 / 994-158 or -159.

ARI-Valves of EN-JL1040 are not allowed to be operated in systems acc. to TRD 110.

A production allowance acc. to TRB 801 No. 45 exists

The engineer, designing a system or a plant, is responsible for the selection of the correct valve.

Dimensions

	DN	65	80	100	125	150	200	250	300
L	(mm)	290	310	350	400	480	600	730	850
H1	(mm)	245	265	365	395	425	550	720	775
ØC (PN25)	(mm)	--	--	--	--	--	520	520	520
ØC (PN40)	(mm)	175	225	300	300	400	--	--	--
Travel	(mm)	16	20	25	32	40	50	70	80
Kvs-value	(m ³ /h)	73,2	112,2	173	288	410	725	1145	1635
Zeta-value	--	5,3	5,2	5,3	4,7	4,8	4,9	4,8	4,8
Zeta-value ... range of tolerance for Kvs-values acc. to VDI/VDE 2173									

Face-to-face dimension ETE series 1 according to DIN EN 12982

Weights

Figure-No.	DN	65	80	100	125	150	200	250	300
34.040	(kg)	--	--	--	--	--	116	150	250
35.040	(kg)	12	16,8	23,6	40	56	116	150	--

Stop valve - Y-pattern with butt weld ends and bellows seal (Cast steel)

Figure-No.	Nominal pressure	Material	Nominal diameter
34.066	PN25	1.0619+N	DN200-300
	Test: • DIN DVGW-Reg. DG-4313AO 0775		
35.066	PN40	1.0619+N	DN15-250
	Test: • DIN DVGW-Reg. DG-4313AO 0776		
Butt weld ends according to DIN EN 12627 - 4 (refer to page 12)			
Test: • Test approvals TÜ.A/TÜV.AR.186-00 • German TA - Luft TÜV-Test-No. 088-945053			
At high differential pressures a balancing plug is necessary! (refer to page 13)			
DN15-100: Throttling plug as standard (for max. permissible ΔP refer to: Flow diagram)			

Selection of possible applications

Industry, powerstations, flue gas purification plant, processing technology, gas supply, vapour facilities, recycling facilities, vacuum facilities, hot water, heating technology, district heating, thermal oil applications, general plant manufacturing, etc.
(other applications on request)

Selection of possible flow media

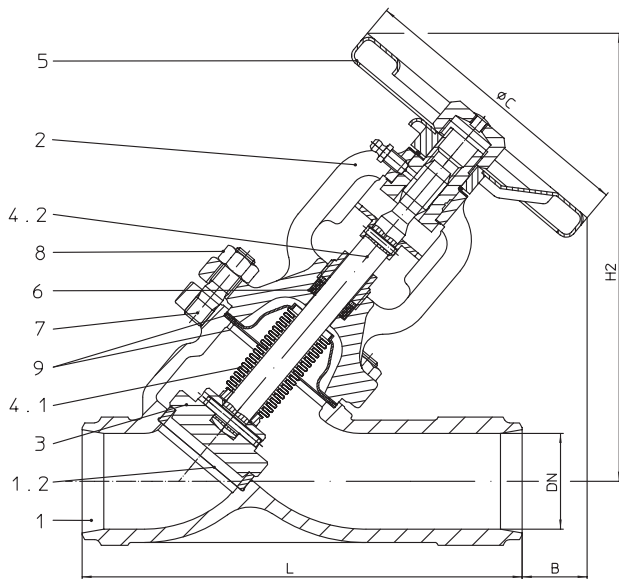
Steam, gases, hot water, thermal oil, process water, vacuum facilities, ammonia etc.
(other flow media on request)

Parts

Pos.	Description	Fig. 34./35.066
1	Body	GP240GH+N, 1.0619+N
1.2	Seat ring	≤DN50: X20Cr13+QT, 1.4021+QT / >DN50: G19 9 NbSi, 1.4551
2	Bonnet	GP240GH+N, 1.0619+N
3	Plug *	≤DN200: X20Cr13+QT, 1.4021+QT / >DN200: P265GH, 1.0425 / G19 9 Nb Si, 1.4551
4.1	Bellows seal *	X6CrNiMoTi17 12 2, 1.4571
4.2	Stem *	X20Cr13+QT, 1.4021+QT
5	Handwheel	≤DN125: St (epoxy-coating) / >DN125: EN-JL 1040, EN-GJL-250 (epoxy-coating)
6	Packing ring *	Pure graphite
7	Stud	25CrMo4, 1.7218
8	Hexagon nut	C35E, 1.1181
9	Gasket *	Pure graphite (CrNi laminated with graphite)

* Spare part

Information / restriction of technical rules need to be observed!

Operating instructions can be ordered by phone +49 (0)5207 / 994-0 or fax +49 (0)5207 / 994-158 or -159.

A production allowance acc. to TRB 801 No. 45 exists

The engineer, designing a system or a plant, is responsible for the selection of the correct valve.

Dimensions

	DN	15	20	25	32	40	50	65	80	100	125	150	200	250	300
L	(mm)	130	150	160	180	200	230	290	310	350	400	480	600	730	850
H2	(mm)	195	195	205	205	235	235	265	295	380	415	480	615	740	795
B	(mm)	85	65	65	50	60	35	10	45	90	60	50	110	100	45
ØC (PN25)	(mm)	--	--	--	--	--	--	--	--	--	--	--	520	520	520
ØC (PN40)	(mm)	126	126	126	126	150	150	175	225	300	300	400	520	520	--
Travel	(mm)	6	6	8	8	13	13	16	20	25	32	40	50	70	80
Kvs-value	(m³/h)	5,7	6,8	12,7	16,8	35,8	47,7	77	107	174	279	406	789	1253	1655
Zeta-value	--	2,5	5,5	3,9	5,9	3,2	4,4	4,8	5,7	5,3	5	4,9	4,1	4	4,7

Zeta-value ... range of tolerance for Kvs-values acc. to VDI/VDE 2173

Face-to-face dimension ETE series 1 according to DIN EN 12982

Weights

Figure-No.	DN	15	20	25	32	40	50	65	80	100	125	150	200	250	300
34.066	(kg)	--	--	--	--	--	--	--	--	--	--	--	131	210	230
35.066	(kg)	2,8	3	3,4	3,2	4,5	7,3	9	11,4	14,3	27,5	62	131	210	--

Stop valve - angle pattern with flanges and bellows seal (Grey cast iron, SG iron, Cast steel)

Figure-No.	Nominal pressure	Material	Nominal diameter
12.047	PN16	EN-JL1040	DN15-300
22.047	PN16	EN-JS1049	DN15-300
	Test: • DIN DVGW-Reg. DG-4313AO 0771		
34.047	PN25	1.0619+N	DN200-300
	Test: • Test approvals TÜ.A/TÜV.AR.186-00 • DIN DVGW-Reg. DG-4313AO 0773		
35.047	PN40	1.0619+N	DN15-150
	Test: • Test approvals TÜ.A/TÜV.AR.186-00 • DIN DVGW-Reg. DG-4313AO 0774		
Test: • German TA - Luft TÜV-Test-No. 088-945053			
At high differential pressures a balancing plug is necessary! (refer to page 13)			
DN15-100: Throttling plug as standard (for max. permissible ΔP refer to: Flow diagram)			

Selection of possible applications

Industry, powerstations, flue gas purification plant, processing technology, gas supply, vapour facilities, recycling facilities, vacuum facilities, hot water, heating technology, district heating, thermal oil applications, general plant manufacturing, etc.
(other applications on request)

Selection of possible flow media

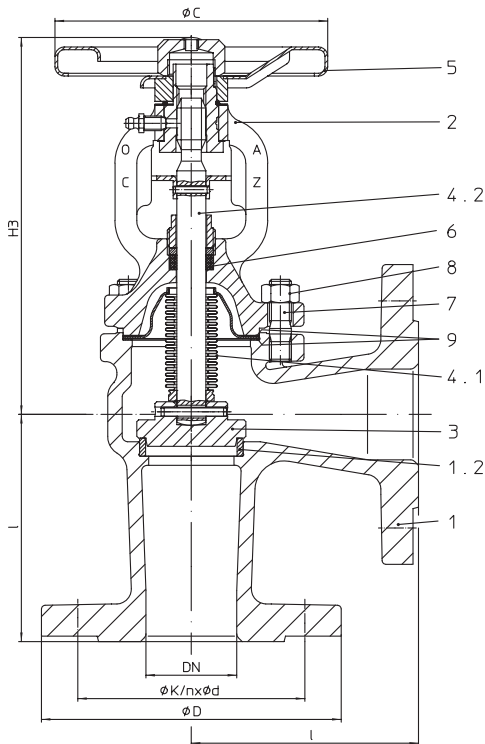
Steam, gases, hot water, thermal oil, process water, vacuum facilities, ammonia etc.
(other flow media on request)

Parts

Pos.	Description	Fig. 12.047	Fig. 22.047	Fig. 34.047 / Fig. 35.047
1	Body	EN-JL1040, EN-GJL-250	EN-JS1049, EN-GJS-400-18U-LT	GP240GH+N, 1.0619+N
1.2	Seat ring	X20Cr13+QT, 1.4021+QT	X20Cr13+QT, 1.4021+QT	≤DN65: X20Cr13+QT, 1.4021+QT >DN65: G19 9 NbSi, 1.4551
2	Bonnet	EN-JS1049, EN-GJS-400-18U-LT	EN-JS1049, EN-GJS-400-18U-LT	≤DN80: P250GH, 1.0460 >DN80: GP240GH+N, 1.0619+N
3	Plug *	≤DN200: X20Cr13+QT, 1.4021+QT / >DN200: P265GH, 1.0425 / G19 9 Nb Si, 1.4551		
4.1	Bellows seal *	X6CrNiMoTi17 12 2, 1.4571		
4.2	Stem *	X20Cr13+QT, 1.4021+QT		
5	Handwheel	≤DN125: St (epoxy-coating) / >DN125: EN-JL1040, EN-GJL-250 (epoxy-coating)		
6	Packing ring *	Pure graphite		
7	Hexagon bolt	5.6	--	
7	Stud	--	25CrMo4, 1.7218	
8	Hexagon nut	--	C35E, 1.1181	
9	Gasket *	Pure graphite (CrNi laminated with graphite)		

* Spare part

Information / restriction of technical rules need to be observed!

Operating instructions can be ordered by phone +49 (0)5207 / 994-0 or fax +49 (0)5207 / 994-158 or -159.

ARI-Valves of EN-JL1040 are not allowed to be operated in systems acc. to TRD 110.

A production allowance acc. to TRB 801 No. 45 exists (acc. to TRB 801 No. 45 EN-JL1040 is not allowed.)

The engineer, designing a system or a plant, is responsible for the selection of the correct valve.

Dimensions

	DN	15	20	25	32	40	50	65	80	100	125	150	200	250	300
l	(mm)	90	95	100	105	115	125	145	155	175	200	225	275	325	375
H3	(mm)	190	190	195	195	210	210	220	235	325	345	370	485	615	665
ØC (PN16/25)	(mm)	126	126	126	126	150	150	175	175	225	300	400	520	520	520
ØC (PN40)	(mm)	126	126	126	126	150	150	175	225	300	300	400	520	--	--
Travel	(mm)	6	6	8	8	13	13	16	20	25	32	40	50	70	80
Kvs-value	(m³/h)	5,2	9,2	15	24	37	58	96	150	235	360	510	905	1430	2040
Zeta-value	--	3	3	2,8	2,9	3	3	3,1	2,9	2,9	3	3,1	3,1	3,1	3,1

Zeta-value ... range of tolerance for Kvs-values acc. to VDI/VDE 2173

Face-to-face dimension CTF series 8 according to DIN EN 558

Weights

Figure-No.	DN	15	20	25	32	40	50	65	80	100	125	150	200	250	300
12. / 22.047	(kg)	3,7	4,4	5,1	6,5	8,3	11,2	14,6	19,4	29,4	44	58	99	161	235
34.047	(kg)	--	--	--	--	--	--	--	--	--	--	--	124	153	261
35.047	(kg)	4,6	6,4	6,7	7,5	10,1	12,7	17,5	22	34	49	60	--	--	--

Stop valve - straight through with long bellow and flanges and bellows seal (Cast steel)

Figure-No.	Nominal pressure	Material	Nominal diameter
34.044	PN25	1.0619+N	DN15-400
35.044	PN40	1.0619+N	DN15-400
DN500 on request			
Test: German TA - Luft TÜV-Test-No. 088-945053			
At high differential pressures a balancing plug is necessary! (refer to page 13)			
DN15-300: Plug with marginal seat standard			

Bellows seal out of media flow path.
Especially for pulsating, turbulent flow directly behind pumps, elbows, junctions, etc.

Selection of possible applications

Industry, powerstations, flue gas purification plant, processing technology, gas supply, vapour facilities, recycling facilities, vacuum facilities, hot water, heating technology, district heating, thermal oil applications, general plant manufacturing, etc.
(other applications on request)

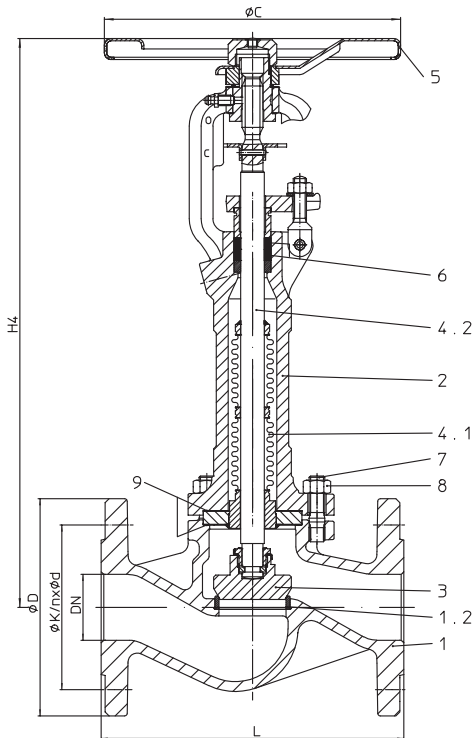
Selection of possible flow media

Steam, gases, hot water, thermal oil, process water, vacuum facilities, ammonia etc.
(other flow media on request)

Parts

Pos.	Description	Fig. 34.040 / 35.040
1	Body	GP240GH+N, 1.0619+N
1.2	Seat ring / Seat	≤DN50: X20Cr13+QT, 1.4021+QT / >DN50: G19 9 NbSi, 1.4551
2	Bonnet	GP240GH+N, 1.0619+N
3	Plug *	X39CrMo17-1+QT, 1.4122+QT
4.1	Bellows seal *	X6CrNiMoTi17 12 2, 1.4571
4.2	Stem *	X6CrNiTi18-10, 1.4541
5	Handwheel	≤DN125: St (epoxy-coating) / >DN125: EN-JL1040, EN-GJL-250 (epoxy-coating)
6	Packing ring *	Pure graphite
7	Stud	25CrMo4, 1.7218
8	Hexagon nut	C35E, 1.1181
9	Gasket *	Pure graphite (CrNi laminated with graphite)

* Spare part

Information / restriction of technical rules need to be observed!

Operating instructions can be ordered by phone +49 (0)5207 / 994-0 or fax +49 (0)5207 / 994-158 or -159.

A production allowance acc. to TRB 801 No. 45 exists

The engineer, designing a system or a plant, is responsible for the selection of the correct valve.

Dimensions

	DN	15	20	25	32	40	50	65	80	100	125	150	200	250	300	350	400
L	(mm)	130	150	160	180	200	230	290	310	350	400	480	600	730	850	980	1100
H4	(mm)	325	325	335	335	430	435	450	460	620	645	680	830	915	955	1255	1270
ØC	(mm)	175	175	175	175	225	225	225	225	300	300	400	520	520	520	640	640
Travel	(mm)	7	7	10	10	17	17	20	20	36	40	40	50	65	75	90	100
Kvs-value	(m³/h)	4,2	7,4	12	19	31	45	76	107	173	288	410	725	1145	1635	2220	3180
Zeta-value	--	4,6	4,7	4,3	4,6	4,3	4,9	4,9	5,7	5,3	4,7	4,8	4,9	4,8	4,8	4,9	4

Zeta-value ... range of tolerance for Kvs-values acc. to VDI/VDE 2173

Standard-flange dimensions refer to page 15

Face-to-face dimension FTF series 1 according to DIN EN 558

Weights

Figure-No.	DN	15	20	25	32	40	50	65	80	100	125	150	200	250	300	350	400
34./35.044	(kg)	6,1	7	8	10	13,3	16	24	28	42	65	90	170	300	360	410	600

Stop valve - straight through with long bellow and butt weld ends and bellows seal (Forged steel)

Figure-No.	Nominal pressure	Material	Nominal diameter
45.067	PN40	1.0460	DN15-50
Butt weld ends according to DIN EN 12627 - 4 (refer to page 12)			
Test: • German TA - Luft TÜV-Test-No. 088-945053			
Plug with marginal seat standard			

Bellows seal out of media flow path.
Especially for pulsating, turbulent flow directly behind pumps, elbows, junctions, etc.

Selection of possible applications

Industry, powerstations, flue gas purification plant, processing technology, gas supply, vapour facilities, recycling facilities, vacuum facilities, hot water, heating technology, district heating, thermal oil applications, general plant manufacturing, etc.
(other applications on request)

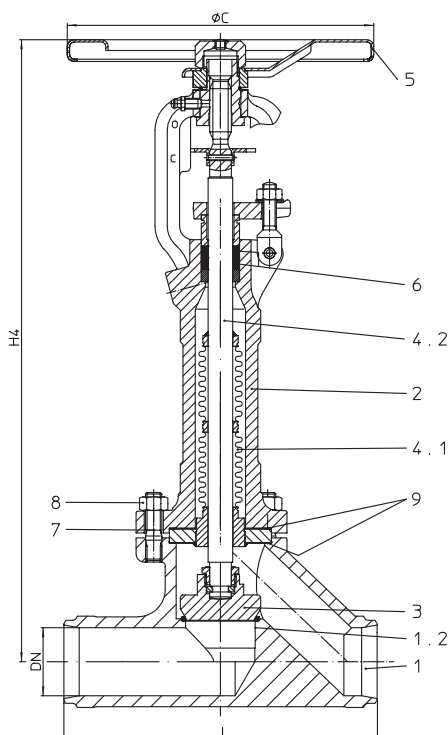
Selection of possible flow media

Steam, gases, hot water, thermal oil, process water, vacuum facilities, ammonia etc.
(other flow media on request)

Parts

Pos.	Description	Fig. 45.067
1	Body	P250 GH, 1.0460
1.2	Seat	G19 9 NbSi, 1.4551
2	Bonnet	GP240GH+N, 1.0619+N
3	Plug *	X39CrMo17-1+QT, 1.4122+QT
4.1	Bellows seal *	X6CrNiMoTi17 12 2, 1.4571
4.2	Stem *	X6CrNiTi18-10, 1.4541
5	Handwheel	Fe P01, 1.0330 (epoxy-coating)
6	Packing ring *	Pure graphite
7	Stud	25CrMo4, 1.7218
8	Hexagon nut	C35E, 1.1181
9	Gasket *	Pure graphite (CrNi laminated with graphite)

* Spare part

Information / restriction of technical rules need to be observed!

Operating instructions can be ordered by phone +49 (0)5207 / 994-0 or fax +49 (0)5207 / 994-158 or -159.

A production allowance acc. to TRB 801 No. 45 exists

The engineer, designing a system or a plant, is responsible for the selection of the correct valve.

Dimensions

	DN	15	20	25	32	40	50
L	(mm)	130	150	160	180	200	230
H4	(mm)	325	325	335	335	430	435
ØC	(mm)	175	175	175	175	225	225
Travel	(mm)	7	7	10	10	17	17
Kvs-value	(m³/h)	3,3	5,8	9,2	15	23,3	36
Zeta-value	--	7,4	7,6	7,4	7,4	7,5	7,7

Zeta-value ... range of tolerance for Kvs-values acc. to VDI/VDE 2173

Face-to-face dimension ETE series 1 according to DIN EN 12982

Weights

Figure-No.	DN	15	20	25	32	40	50
45.067	(kg)	4,7	5,1	6	7	9	11,5

Stop valve - straight through with long bellow and butt weld ends and bellows seal (Cast steel)

Figure-No.	Nominal pressure	Material	Nominal diameter
35.067	PN40	1.0619+N	DN65-300
Butt weld ends according to DIN EN 12627 - 4 (refer to page 12) alternative: DN 65-200 with shoed ends of P235GH			
Test: • German TA - Luft TÜV-Test-No. 088-945053			
At high differential pressures a balancing plug is necessary! (refer to page 13)			
Plug with marginal seat standard			

Bellows seal out of media flow path.
Especially for pulsating, turbulent flow directly behind pumps, elbows, junctions, etc.

Selection of possible applications

Industry, powerstations, flue gas purification plant, processing technology, gas supply, vapour facilities, recycling facilities, vacuum facilities, hot water, heating technology, district heating, thermal oil applications, general plant manufacturing, etc.
(other applications on request)

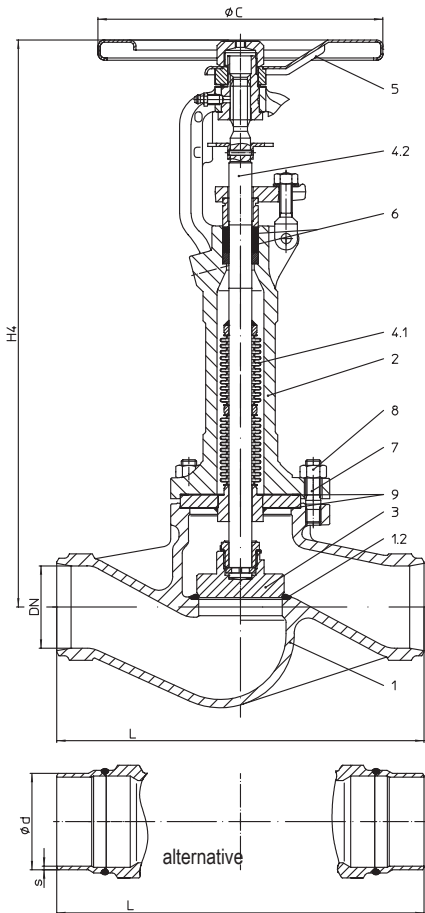
Selection of possible flow media

Steam, gases, hot water, thermal oil, process water, vacuum facilities, ammonia etc.
(other flow media on request)

Parts

Pos.	Description	Fig. 35.067
1	Body	GP240GH+N, 1.0619+N
1.2	Seat	G19 9 NbSi, 1.4551
2	Bonnet	GP240GH+N, 1.0619+N
3	Plug *	X39CrMo17-1+QT, 1.4122+QT
4.1	Bellows seal *	X6CrNiMoTi17 12 2, 1.4571
4.2	Stem *	X6CrNiTi18-10, 1.4541
5	Handwheel	≤DN125: St (epoxy-coating) / >DN125: EN-JL1040, EN-GJL-250 (epoxy-coating)
6	Packing ring *	Pure graphite
7	Stud	25CrMo4, 1.7218
8	Hexagon nut	C35E, 1.1181
9	Gasket *	Pure graphite (CrNi laminated with graphite)

* Spare part

Information / restriction of technical rules need to be observed!

Operating instructions can be ordered by phone +49 (0)5207 / 994-0 or fax +49 (0)5207 / 994-158 or -159.

A production allowance acc. to TRB 801 No. 45 exists

The engineer, designing a system or a plant, is responsible for the selection of the correct valve.

Dimensions

	DN	65	80	100	125	150	200	250	300
L	(mm)	290	310	350	400	480	600	730	850
H4	(mm)	450	460	620	645	680	830	915	955
ØC	(mm)	225	225	300	300	400	520	520	520
Travel	(mm)	20	20	36	40	40	50	65	75
Kvs-value	(m³/h)	76	107	173	288	410	725	1145	1635
Zeta-value	--	4,9	5,7	5,3	4,7	4,8	4,9	4,8	4,8

Zeta-value ... range of tolerance for Kvs-values acc. to VDI/VDE 2173

Face-to-face dimension ETE series 1 according to DIN EN 12982

Weights

Figure-No.	DN	65	80	100	125	150	200	250	300
35.067	(kg)	18,	22	32	50	70	130	245	290

Stop valve - Y-pattern with long bellow and butt weld ends and bellows seal (Cast steel)

Figure-No.	Nominal pressure	Material	Nominal diameter
35.068	PN40	1.0619+N	DN200-300
Butt weld ends according to DIN EN 12627 - 4 (refer to page 12)			
Test: • German TA - Luft TÜV-Test-No. 088-945053			
At high differential pressures a balancing plug is necessary! (refer to page 13)			
Plug with marginal seat standard			

Bellows seal out of media flow path.
Especially for pulsating, turbulent flow directly behind pumps, elbows, junctions, etc.

Selection of possible applications

Industry, powerstations, flue gas purification plant, processing technology, gas supply, vapour facilities, recycling facilities, vacuum facilities, hot water, heating technology, district heating, thermal oil applications, general plant manufacturing, etc.
(other applications on request)

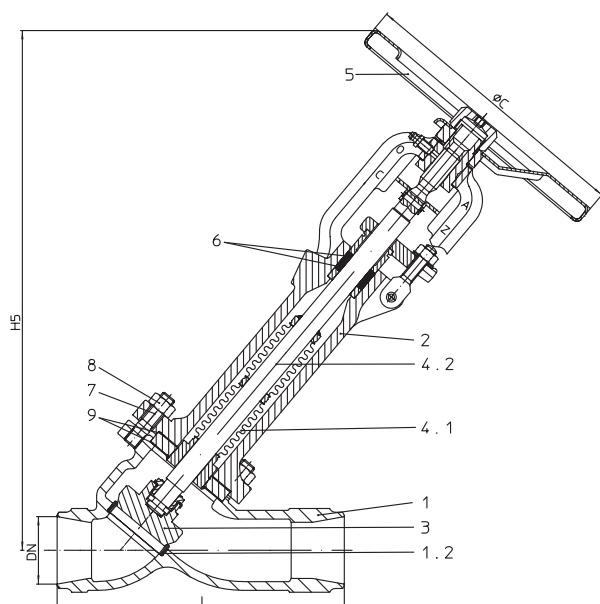
Selection of possible flow media

Steam, gases, hot water, thermal oil, process water, vacuum facilities, ammonia etc.
(other flow media on request)

Parts

Pos.	Description	Fig. 35.068
1	Body	GP240GH+N, 1.0619+N
1.2	Seat	G19 9 NbSi, 1.4551
2	Bonnet	GP240GH+N, 1.0619+N
3	Plug *	X39CrMo17-1+QT, 1.4122+QT
4.1	Bellows seal *	X6CrNiMoTi17 12 2, 1.4571
4.2	Stem *	X6CrNiTi18-10, 1.4541
5	Handwheel	EN-JL1040, EN-GJL-250 (epoxy-coating)
6	Packing ring *	Pure graphite
7	Stud	25CrMo4, 1.7218
8	Hexagon nut	C35E, 1.1181
9	Gasket *	Pure graphite (CrNi laminated with graphite)

* Spare part

Information / restriction of technical rules need to be observed!

Operating instructions can be ordered by phone +49 (0)5207 / 994-0 or fax +49 (0)5207 / 994-158 or -159.

A production allowance acc. to TRB 801 No. 45 exists

The engineer, designing a system or a plant, is responsible for the selection of the correct valve.

Dimensions

	DN	200	250	300
L	(mm)	600	730	850
H5	(mm)	830	890	935
ØC	(mm)	520	520	520
Travel	(mm)	50	65	75
Kvs-value	(m³/h)	709	1253	1655
Zeta-value	--	5,1	4	4,7

Zeta-value ... range of tolerance for Kvs-values acc. to VDI/VDE 2173

Face-to-face dimension ETE series 1 according to DIN EN 12982

Weights

Figure-No.	DN	200	250	300
35.068	(kg)	110	245	290

L = Face-to-face dimension
 Edge shaping acc. to DIN EN 25817

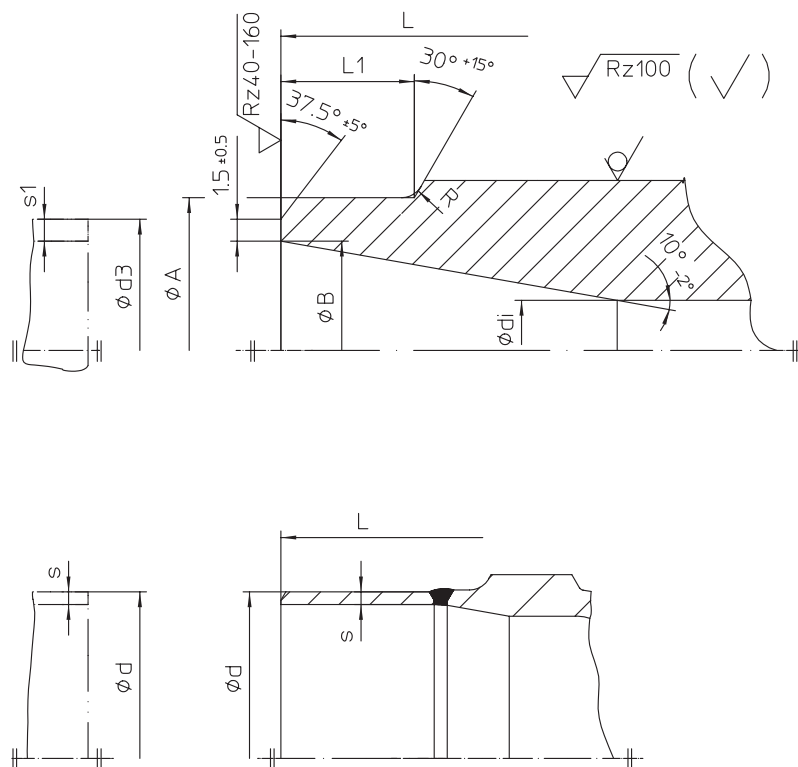
Butt weld ends according to DIN EN 12627 - 4

	DN	15	20	25	32	40	50	65	80	100	125	150	200	250	300	350	400
L	(mm)	130	150	160	180	200	230	290	310	350	400	480	600	730	850	980	1100
ØA	(mm)	22	28	35	44	50	62	77	91	117	144	172	223	278	329	362	413
ØB	(mm)	17,3	22,3	28,5	37,2	43,1	53,9	68,9	80,9	104,3	130,7	157,1	204,9	257,	307,9	338,	384,4
Ødi	(mm)	15	20	25	32	40	50	65	80	100	125	150	200	250	300	330	375
R	(mm)	3	3	3	3	3	3	3	3	3	3	3	5	5	5	5	5
L1	(mm)	10	10	10	10	10	10	10	12	14	18	20	20	25	33	45	45
Ød3	(mm)	21,3	26,9	33,7	42,4	48,3	60,3	76,1	88,9	114,3	139,7	168,3	219,1	273	323,9	355,6	406,4
s1	(mm)	2	2,3	2,6	2,6	2,6	3,2	3,6	4	5	4,5	5,6	7,1	8	8	8,8	11

Shoed ends of P235GH (Pipe connection ≙ welding neck flanges)

	DN	15	20	25	32	40	50	65	80	100	125	150	200	250	300	350	400
Ød	(mm)	--	--	--	--	--	--	76,1	88,9	114,3	139,7	168,3	219,1	--	--	--	--
Øs	(mm)	--	--	--	--	--	--	2,9	3,2	3,6	4	4,5	6,3	--	--	--	--

Face-to-face dimension ETE series 1 according to DIN EN 12982.

Butt weld ends according to DIN EN 12627 - 4.

Weld joint according to DIN EN 29692 code numer 1.3.3.

The material used for ARI valves with butt weld ends are:

GP240GH+N, 1.0619+N acc. to DIN EN 10213-2,

P250GH, 1.0460 acc. to DIN EN 10222-2.

The material used for ARI valves with shoed ends (DN 65-200) P235GH according to DIN EN 10216-2.

Based on our experience we recommend electric welding process for connecting valves or strainers with tubes or with each other

Lime based electrodes with an appropriate composite material should be used as filler material for welding.

Gas welding should be avoided.

Due to the different material composition and material thickness of valves and tubes, gas welding is more susceptible to produce faults than electric welding (hardness cracks, coarse-grained structure).

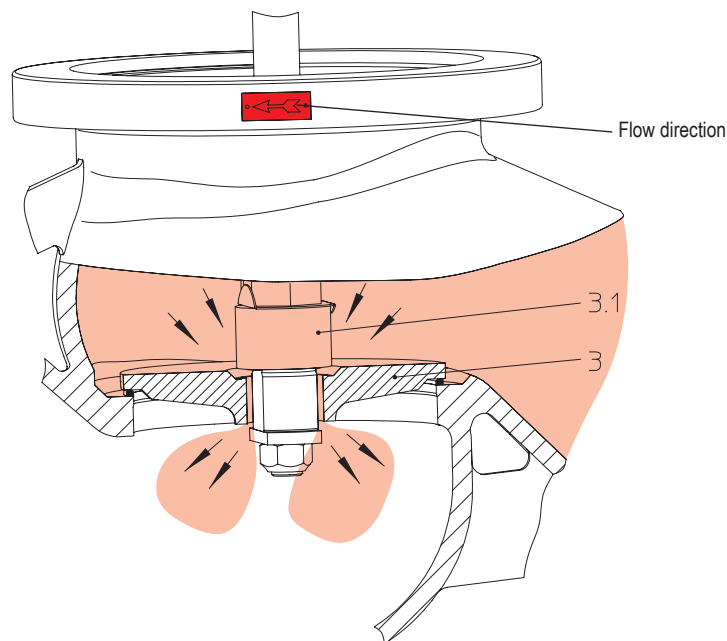
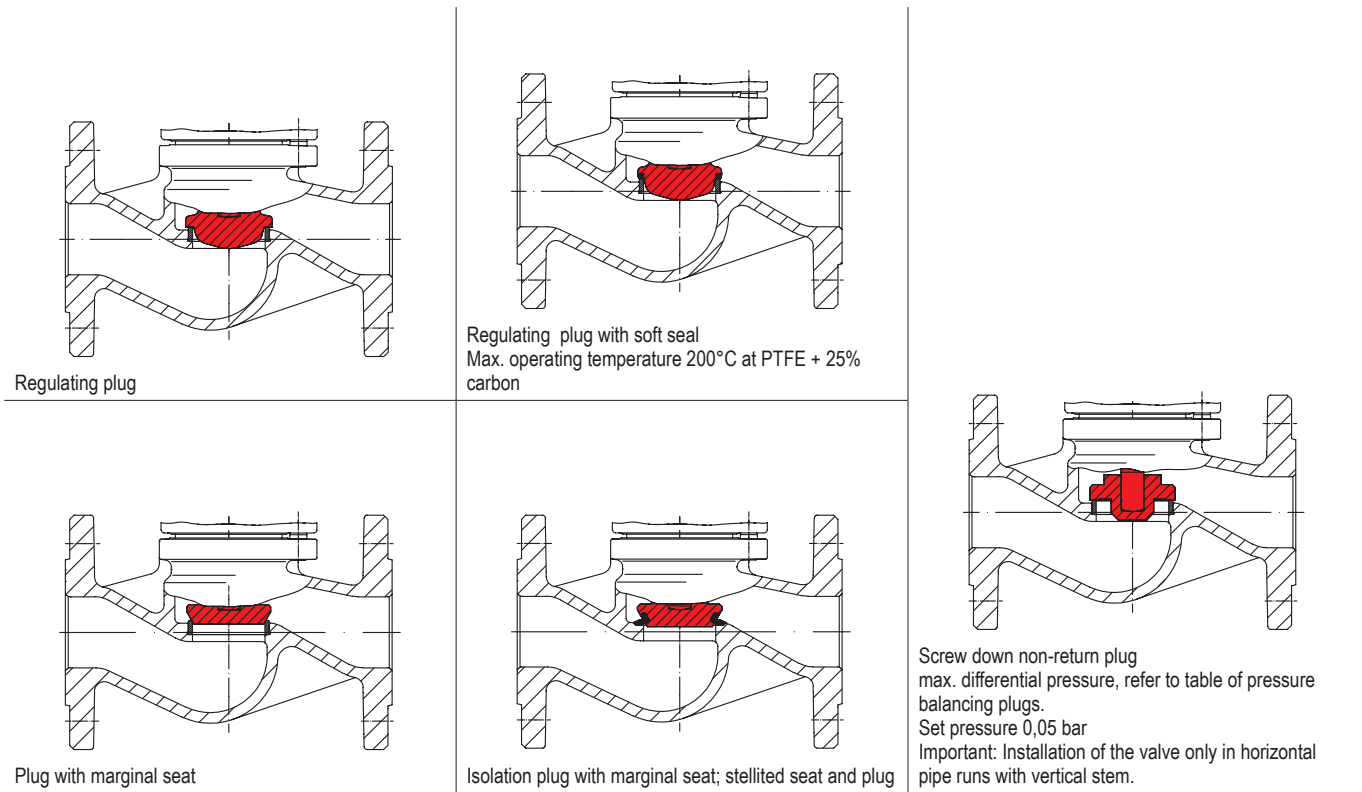

Valves with balancing plugs have to be installed with medium flowing over the plug (3) as indicated by flow direction arrow on valve body.

Working principles:

When the valve is closed, anticlockwise rotation of the hand wheel lifts the pilot plug (3.1) off the larger balancing plug (3).

This allows the medium to pass through the plug and equalizes the pressure of the medium under the plug (3). After the pressures have been equalized within the valves stated in the table, the valve can be opened by turning the valve further with normal manual force.

Balancing plugs are fully effective only in closed systems.

The pressures of the medium on either side of the plug can not be equalized if the medium is discharged into open air.

A bypass line or some other arrangement is necessary if too much time is required for pressure equalization owing to the volume in the piping system.

ARI-stop valves with differential pressures exceeding the following pressures, have to be fitted with pressure balancing plugs

	DN	125	150	200	250	300	350	400	500
Differential pressure (ΔP)	(bar)	25	21	14	9	6	4,5	3,5	1,5

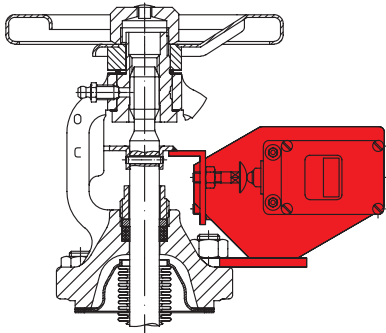

Limit switch

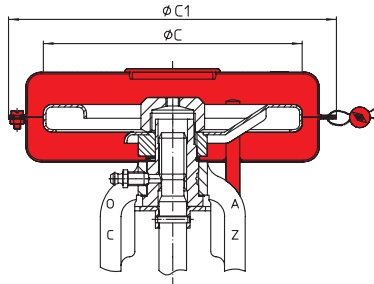

Hood valve
(tamper resistant handwheel cover)

Size	DN	ØC	ØC1
	(mm)	(mm)	(mm)
I	15-32	126	170
II	40-80	150	190
III	100-150	225	330

Handwheel-Ø from DN 65 reduced!

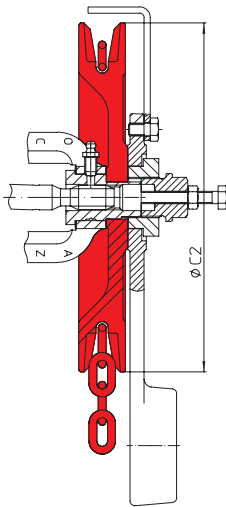

Chain wheel

DN	ØC2	Weight
(mm)	(mm)	(kg)
15-32	180	2,5
40-80	220	7
100-150	260	8,9
200-400	300	11

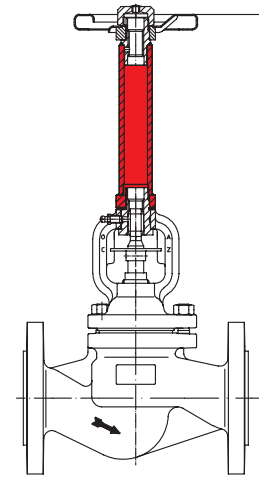

Stem extension (please specify height in your order)

Accessories: Travel limiter

Standard: Lubricating nipple, locking device

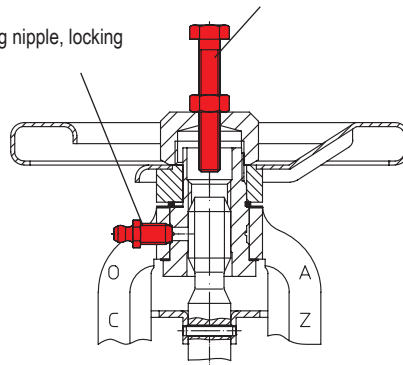

Lubricating nipple / locking device / travel limiter

Application of lubricating nipples

Functions:

1. Lubrication
(prevents the handwheel jamming)
2. Locking screw
(allows valve to be locked-off at desired travel)
3. Lubrication an locking
(lubrication with locked handwheel possible)

Travel limiter

(Accessories are not included !)

DN	Hexagon bolt
(mm)	(mm x mm)
15-80	M8 x 55
100	M12 x 70
125-150	M12 x 80
200	M12 x 100
250-300	M12 x 120
350-400	M16 x 160

Standard-flange dimensions

Flanges acc. to DIN EN 1092-1/2 (Flangeholes / -thickness tol. acc. to DIN 2533/2544/2545)

DN		(mm)	15	20	25	32	40	50	65	80	100	125	150	200	250	300	350	400	500
PN6	ØD	(mm)	80	90	100	120	130	140	160	190	210	240	265	320	--	--	--	--	--
PN6	ØK	(mm)	55	65	75	90	100	110	130	150	170	200	225	280	--	--	--	--	--
PN6	n x Ød	(mm)	4x11	4x11	4x11	4x14	4x14	4x14	4x14	4x18	4x18	8x18	8x18	8x18	--	--	--	--	--
PN16	ØD	(mm)	95	105	115	140	150	165	185	200	220	250	285	340	405	460	520	580	715
PN16	ØK	(mm)	65	75	85	100	110	125	145	160	180	210	240	295	355	410	470	525	650
PN16	n x Ød	(mm)	4x14	4x14	4x14	4x18	4x18	4x18	4x18	8x18	8x18	8x18	8x22	12x22	12x26	12x26	16x26	16x30	20x33
PN25	ØD	(mm)	95	105	115	140	150	165	185	200	235	270	300	360	425	485	555	620	730
PN25	ØK	(mm)	65	75	85	100	110	125	145	160	190	220	250	310	370	430	490	550	660
PN25	n x Ød	(mm)	4x14	4x14	4x14	4x18	4x18	4x18	8x18	8x18	8x22	8x26	8x26	12x26	12x30	16x30	16x33	16x36	20x36
PN40	ØD	(mm)	95	105	115	140	150	165	185	200	235	270	300	375	450	515	580	660	755
PN40	ØK	(mm)	65	75	85	100	110	125	145	160	190	220	250	320	385	450	510	585	670
PN40	n x Ød	(mm)	4x14	4x14	4x14	4x18	4x18	4x18	8x18	8x18	8x22	8x26	8x26	12x30	12x33	16x33	16x36	16x39	20x42

Pressure-temperature-ratings acc. to DIN EN 1092-2

Material	PN		-60°C to <-10°C*	-10°C to 120°C	150°C	200°C	250°C	300°C	350°C	400°C	450°C
EN-JL1040	16	bar	--	16	14,4	12,8	11,2	9,6	--	--	--
EN-JS1049	16	bar	on request	16	15,5	14,7	13,9	12,8	11,2	--	--
EN-JS1049	25	bar	on request	25	24,3	23	21,8	20	17,5	--	--
EN-JS1049	40	bar	on request	40	38,8	36,8	34,8	32	28	--	--

Pressure-temperature-ratings acc. to DIN EN 1092-1

Material	PN		-60°C to <-10°C*	-10°C to 50°C	100°C	150°C	200°C	250°C	300°C	350°C	400°C	450°C
1.0619+N	25	bar	18,7	25	23,3	21,7	19,4	17,8	16,1	15	14,4	13,9
1.0619+N	40	bar	30	40	37,3	34,7	30,2	28,4	25,8	24	23,1	22,2
1.0460	25	bar	18,7	25	23,3	31,7	19,4	17,8	16,1	15	14,4	10
1.0460	40	bar	30	40	37,3	34,7	30,2	28,4	25,8	24	23,1	16

Intermediate values for max. permissible operational pressures can be determined by linear interpolation of the given temperature / pressure chart.

* Studs and nuts made of A4-70 (at temperatures below -10°C)

Please indicate when ordering

- Figure-No.
- Nominal pressure
- Nominal diameter
- Special design / accessories

Example:

Figure 35.046; nominal pressure PN40; nominal diameter DN100.

 Dimensions in mm
 Weights in kg
 1 bar $\hat{=}$ 10⁵ Pa $\hat{=}$ 0,1 MPa
 Kvs in m³/h



Technology for the Future.
GERMAN QUALITY VALVES

ARI-Armaturen Albert Richter GmbH & Co. KG, D-33756 Schloß Holte-Stukenbrock,
Tel. +49 52 07 / 994-0, Telefax +49 52 07 / 994-158 or 159 Internet: <http://www.ari-armaturen.com> E-mail: info.vertrieb@ari-armaturen.com