

Work with

- | | |
|------------------|----------|
| * ATI | * Sauter |
| * Barber coleman | * Staefa |
| * Honeywell | * T/A |
| * Johnson | * TEG |
| * Landis & Gyr | * Others |
| * Satchwell | |

Electric Rotary Actuators

Synchronous motor drives, Modulating with Magnetic coupling safety system

AQR65.1.

AQR65.12120

- Aux. output 1=spt 2=140Ω 3=1000Ω 9=Converter
- Output Torque(Nm); 1=7.5N 2=15 3=20 4=30 9=Options
- Running time; 1=120s 2=60s 3=30s 4=15s 5=10s 6=5s 9=Options
- Supply voltage
- 1=110Vac, 2=24Vac, 3=220Vac, 4=380Vac, 7=12Vdc, 8=24Vdc
- 1=Rotary 2=Linear 9=Options
- Version No.
- Input signal: 2=On/Off, 3=3-pos. 220Vac, 5=4..20mA 6=0..10Vdc
- 7=0..20Vdc, 8=3-pos. 24Vac, 9=0..135Ω
- R=Damper
- Type of drive motor
- I= Induction, Q= Synchronous, S= Servo, U= DC, Z= Stepper
- Product group: A= Actuator

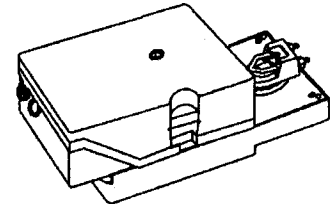

Description

Electrical actuator, 0...10Vdc control, rotating angle is 90 and magnetic coupling with mechanical limitation system without spring return.

Application

In heating, ventilating, air conditioning and other industrial installations for control of air dampers, VAV terminals and other ventilating openings to be controlled by electrical remote control.

Signals from other controllers are also acceptable.

Ordering Specification

When ordering, please give full designation and type reference of unit;

Ex: AQR65.12120 Electrical Damper Actuator Proportional, 0..10Vdc Rotary type, 120s, 24Vac, 15Nm for aux unit

STANDARD STOCK TYPE

AQR65.12110 AQR65.12120 AQR65.12130

Technical Data

Supply voltage	24V ac ± 20%
Frequency	50Hz, 60Hz
Power source	Synchronous motor
Power consumption	3VA...
Running time	125s at 60Hz. 150s at 50Hz
Model of control	Proportional(std)
Travel /angular rotation	90 (std)
Noise level	35[dB] max.
Nominal Torque	15Nm.constant
Control signal(Y)	
Voltage	0...10Vdc
Current	0.1mA max.
Control signal(R)	
Resistance	0...1000Ω (0...100%)
Control output(U)	
Voltage	Optional
Current	0...10Vdc(std) 0.5mA max.
Weight	1.Kg
Permissible amb.temp.	
Operation	-15...+50°C
Transport & storage	-30...+65°C
Permissible amb.humid.	class D to DIN 40040
Protection standard of housing	IP54 to DIN 40050
Max. medium temp.	+150 °C
Cable entry glands	PG11

Accessories;

position indication unit	
-potentiometer	-0...140
-potentiometer	-0...1000
position alarm switch	
-snap action switch	10(3)A 24...250Vac
Estimated life time	
-Drive motor	40,000,000 cycles
-Gear train	80,000,000 cycles

Summary of types

Type Nr.	Output Torque	Running time		Space for Aux.units			
		50Hz	60Hz	0	1	2	3
AQR65.12120	7.5Nm	150s	125s	0	SW	140Ω	1000Ω
AQR65.12140	15Nm	150s	125s	0	SW	140Ω	1000Ω
AQR65.12150	20Nm	150s	125s	0	SW	140Ω	1000Ω
AQR65.12180	30Nm	150s	125s	0	SW	140Ω	1000Ω
AQR65.12210	7.5Nm	72s	60s	0	SW	140Ω	1000Ω
AQR65.12220	15Nm	72s	60s	0	SW	140Ω	1000Ω
AQR65.12230	20Nm	72s	60s	0	SW	140Ω	1000Ω
AQR65.12240	30Nm	72s	60s	0	SW	140Ω	1000Ω

Function

The actuator is controlled by a standard signal of 0...10Vdc received from conventional electronic controller or DDC unit. It provides electronic position control which, in conjunction with ATI or any compatible venturi type air dampers or air valves, gives an equal percentage valve characteristic.

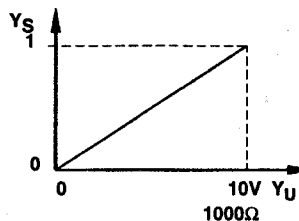

Correlation between control signal and correcting variable

Y_S = Correcting variable
Y_U = control signal 0...10Vdc
Y_R = correcting signal 0...10Vdc

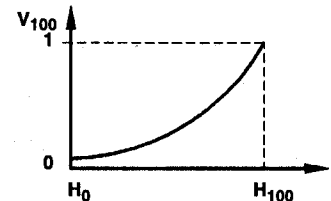

Correlation between valve stroke and volumetric flow

V₁₀₀ = volumetric flow
H_{..} = valve stroke

Auxiliary units

Control output U with a 0...10Vdc control signal allows control of the following units:

- Indication units
- On / Off switching units

Design Features

Actuator are supplied as separate units. Assembling them requires neither special tools nor adjustments.

- Maintenance free electrical actuator with reversible synchronous motor
- A switch on PCB can reverse the rotation of the actuator.
- Blocking proof gear train with self-lubrication sintered bearings
- Quick mounting bracket make easy installation.
- Constant speed and constant power-torque-
- Contactless coupling insures long life and quite operation.
- Gear train is made of aluminum die-cast and specially coated for corrosion proof.
- Important gears are made of sintered metal or special tool steel and heat treatment.

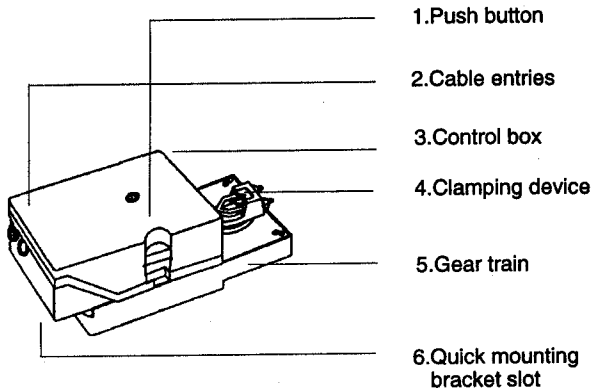

Special features

Utilizing hysteresis coupling technology gives more safer operation of actuators by providing constant output force and speed.

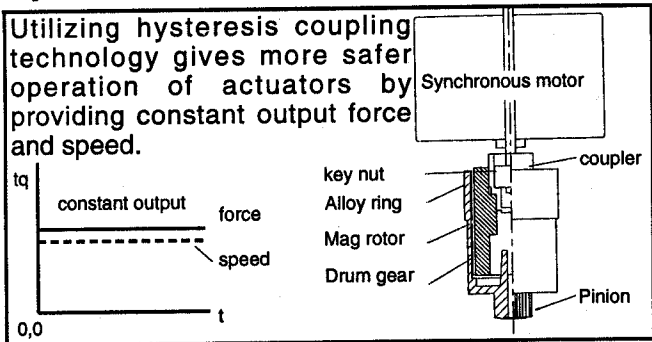

Application Advice

For further information on the complete regulating unit consist of actuator and valve also refer to the Data Sheet of the various type of valves, 4300... 4499. Observe the permissible temperatures. For details refer to <Application > and <Technical Data>

Dimensions

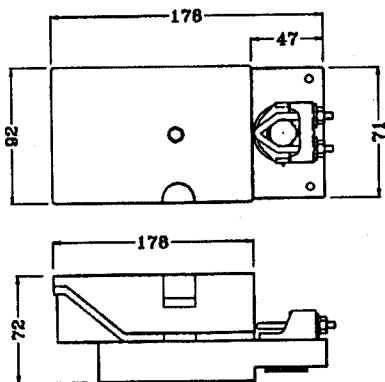

Dimensions in mm

Data Sheet 34001 contains basic system data on POLYTEK. All hints and explanations given in this sheet must be observed.

All units connected to terminals Y and U, together with the AQR..., must be connected to the same G0. The factory fitted link across terminals R and M may be removed only if a unit is connected between these terminals.

Mounting and Installation Advice

Mounting positions:

The actuator's mounting instructions are supplied in the box of the unit.

Commissioning Advice

When commissioning the installation, check the wiring and make a functional test.

Wiring Diagram

Internal Diagram

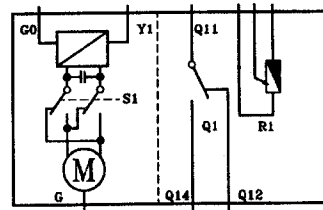

- G, G0 = Operating voltage 24Vac
- G = system potential (SP)
- G0 = system neutral (SN)
- Y = control signal 0...10Vdc
- S1 = Change-over switch
- Q1 = Switch unit
- R1 = Potentiometer
- M = Synchronous motor

Connecting terminals

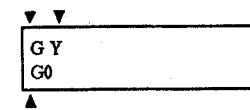

Wiring diagram

The wiring diagram shows all possible connections. How many and which of these are used depends on the system involved.

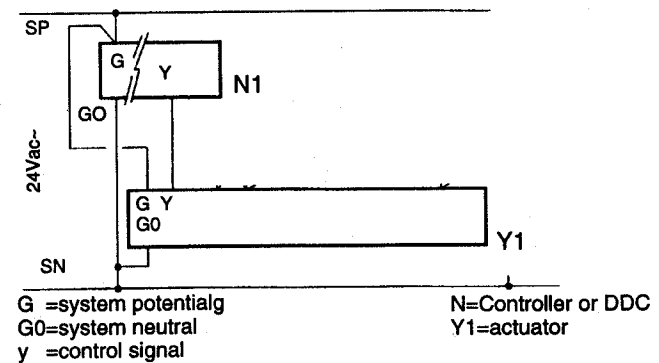

We reserve the right to make changes and improvements in our products which may affect the accuracy of the information contained in this leaflet.