

■ Contents
Introduction to HVAC

Software version	3
Safety regulations	4
Warning against unintended start	4
Introduction to the Design Guide	5
Available literature	7
Why use a frequency converter for controlling fans and pumps?	8
The clear advantage - energy savings	8
Example with varying flow over 1 year	9
Control principle	12
PC software and serial communication	15
CE-labelling	16
Application examples	17
Specification text	24
Ordering guide	30
Choice of frequency converter	30
Unpacking and ordering a VLT frequency converter	34
Type code ordering number string	34
Ordering form VLT 6000 HVAC	35

Installation

General technical data	42
Mains supply 3 x 200 - 240 V	45
Technical data, mains supply 3 x 380 - 460 V	46
Mechanical dimensions	48
Mechanical installation	50
Enclosure protection	50
Field-mounting	50
General information about electrical installation	52
High voltage warning	52
Earthing	52
Cables	52
Screened/armoured cables	52
Extra protection	52
RFI switch	53
High voltage test	53
Heat emission from VLT 6000 HVAC	53
EMC-correct electrical installation	54
Use of EMC-correct cables	55
Earthing of screened/armoured control cables	56
VLT 6000 HVAC enclosures	57
Tightening-up torque and screw sizes	62
Mains connection	62
Pre-fuses	62
Motor connection	62
DC bus connection	64
High-voltage relay	64
Electrical installation, control cables	65
Connection example, VLT 6000 HVAC	66
Switches 1-4	67

Introduction to HVAC
Installation
Programming
All about VLT 6000 HVAC

Programming

Control unit LCP	69
Quick menu	74
The Setup configuration	75
Setup of user-defined readout	76
Load and Motor 100-117	81
Configuration	81
References & Limits 200 - 228	88
Reference handling	89
Inputs and outputs 300-328	97
Analogue inputs	100
Analogue/digital outputs	103
Relay outputs	106
Application functions 400-427	108
Sleep mode	109
PID for process control	113
PID overview	115
Serial communication for FC protocol	121
Protocols	121
Telegram communication	121
Telegram build-up under FC protocol	122
Data character (byte)	123
Process word	127
Control word as per FC protocol	127
Status word as per FC protocol	129
Serial communication 500 - 556	132
Warning words 1+2 and Alarm word	140
Service functions 600-631	142

All about VLT 6000 HVAC

Status messages	148
List of warnings and alarms	150
Aggressive environments	156
Calculation of resulting reference	156
Extreme running conditions	158
Peak voltage on motor	159
Derating for ambient temperature	160
Efficiency	162
Definitions	167
Factory settings	169
Index	175

VLT 6000 HVAC

Design Guide
Software version: 1.0x



This Design Guide can be used with all VLT 6000 HVAC frequency converters that have software version 1.0x. See software version number in parameter 624 *Software version no.*



The voltage of the frequency converter is dangerous whenever the equipment is connected to mains. Incorrect installation of the motor or the frequency converter may cause damage to the equipment, serious personal injury or death. Consequently, the instructions in this manual, as well as national and local rules and safety regulations, must be complied with.

■ **Safety regulations**

1. The VLT frequency converter must be disconnected from mains if repair work is to be carried out.
Check that the mains supply has been disconnected and that the necessary time has passed before removing motor and mains plugs.
2. The [OFF/STOP] key on the control panel of the VLT frequency converter does not disconnect the equipment from mains and is thus not to be used as a safety switch.
3. Correct protective earthing of the equipment must be established, the user must be protected against supply voltage, and the motor must be protected against overload in accordance with applicable national and local regulations.
4. The earth leakage currents are higher than 3.5 mA.
5. Protection against motor overload is not included in the factory setting. If this function is required, set parameter 117, *Motor thermal protection*, to data value ETR trip or data value ETR warning.
Note: The function is initialised at 1.0 x rated motor current and rated motor frequency (see page 87).
For the North American market: The ETR functions ensure overload protection of the motor, Class 20, in accordance with NEC.

6. Do not remove the plugs for the motor and mains supply while the VLT frequency converter is connected to mains. Check that the mains supply has been disconnected and that the necessary time has passed before removing motor and mains plugs.
7. Reliable galvanic isolation (PELV) is not complied with if the RFI switch is placed in OFF position. This means that all control in- and outputs can no longer be considered low-voltage terminals.
8. Please note that the VLT frequency converter has more voltage inputs than L1, L2, L3 when the DC-bus terminals are used.
Check that all voltage inputs have been disconnected and that the necessary time has passed before repair work is commenced.

■ **Warning against unintended start**

1. The motor can be brought to a stop by means of digital commands, bus commands, references or a local stop, while the frequency converter is connected to mains.
If personal safety considerations make it necessary to ensure that no unintended start occurs, these stop functions are not sufficient.
2. While parameters are being changed, the motor may start. Consequently, the stop key [OFF/STOP] must always be activated, following which data can be modified.
3. A stopped motor may start if a fault occurs in the electronics of the VLT frequency converter, or if a temporary overload or a fault in the supply mains or the motor connection ceases.



Warning:

Touching the electrical parts may be fatal - even after the equipment has been disconnected from mains.

Using VLT 6001-6005: wait at least 4 minutes

Using VLT 6006-6275: wait at least 15 minutes

■ Introduction to the Design Guide

This Design Guide is a tool intended to facilitate the sizing of systems in which VLT 6000 HVAC frequency converters are used.

HVAC stands for Heating Ventilation Air-Conditioning.

This Design Guide progresses step-by-step through the different procedures required for selecting, installing and programming a VLT 6000 HVAC.

The Design Guide forms part of the literature concept supplied with VLT 6000 HVAC. However, the Design Guide is the most comprehensive document available.

When a VLT 6000 HVAC is supplied, it is accompanied by *Operating Instructions* and a *Quick Setup Guide*. See next page *Other literature*.

Operating Instructions: Describe how to ensure optimum mechanical and electrical installation, and also deal with commissioning and service. The *Operating Instructions* furthermore provide a description of the software parameters, thereby ensuring that you can easily fit the VLT 6000 HVAC into your application.

Quick Setup Guide: Helps you get your VLT 6000 HVAC installed and commissioned quickly.

Design Guide: Used when designing systems with VLT 6000 HVAC. The *Design Guide* gives all useful information about the VLT 6000 HVAC and HVAC systems. There is a selection tool for you to choose the right VLT 6000 HVAC with the relevant options and modules. The *Design Guide* has examples of the most common types of HVAC applications. In addition, the *Design Guide* has all information relating to Serial Communication.

This Design Guide is split in four sections that have information about VLT 6000 HVAC.

Introduction to HVAC: This section tells you the advantages that can be obtained by using frequency converters in HVAC systems. Furthermore, you can read about the way a frequency converter operates and about the advantages of the VLT 6000 HVAC, such as AEO - Automatic Energy Optimisation, RFI filter and other HVAC-relevant functions.

There are also examples of applications and information is given about Danfoss and CE-labelling.

The specification section deals with the requirements relating to being allowed to supply and install frequency converters. This section can be used in contract documents, whereby the total list of requirements relating to frequency converters is determined.

The section ends with an *Ordering Guide* that makes it easier for you to specify and order a VLT 6000 HVAC.

■ Introduction to the Design Guide

Installation: This section shows you how to carry out correct mechanical installation of a VLT 6000 HVAC. In addition, the section has a description of how you ensure that the installation of the VLT 6000 HVAC is EMC-correct. Furthermore, the section includes a list of mains and motor connections, as well as a description of control card terminals.

Programming: This section describes the control unit and the software parameters for the VLT 6000 HVAC. There is also a guide to the Quick Setup menu, which means that you will be able to start using your application very quickly.

All about VLT 6000: This section has information about status, warning and fault indications from the VLT 6000 HVAC. In addition, the section has technical data, service information, factory settings and information on special conditions.



This symbol indicates something to be noted by the reader.



This symbol indicates a general warning.



This symbol indicates a high-voltage warning.

■ Available literature

The chart below gives an overview of the literature available for the VLT 6000 HVAC. Please note that variations may occur from one country to the next

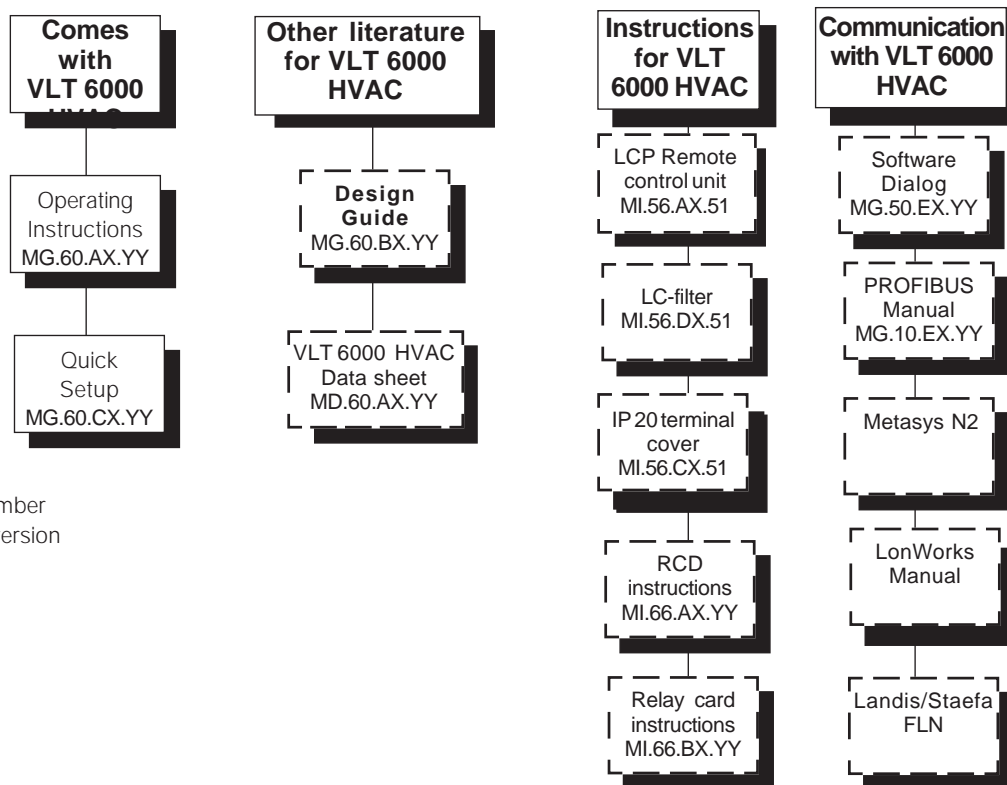

- X = version number
- YY = language version
- 01 = Danish
- 02 = English
- 03 = German
- 04 = French
- 05 = Spanish
- 06 = Italian
- 07 = Swedish
- 10 = Dutch
- 20 = Finnish
- 28 = Brazilian-Portuguese
- 51,52 = Danish, English, German

■ **Why use a frequency converter for controlling fans and pumps?**

A frequency converter takes advantage of the fact that centrifugal fans and pumps follow the laws of proportionality for such fans and pumps.

The graph below describes the laws of proportionality. The graph shows that flow and pressure can be regulated by changing the rpm figure.

■ **The clear advantage - energy savings**

The very clear advantage of using a frequency converter for controlling the speed of fans or pumps lies in the electricity savings to be obtained.

When comparing with alternative regulating systems and technologies, a frequency converter is the optimum energy control system for regulating fan and pump systems.

■ **Example of energy savings**

As can be seen from the figure (the laws of proportionality), the flow is regulated by changing the rpm figure. By reducing the speed only 20% from the rated speed, the flow is also reduced by 20%. This is because the flow is directly proportional to the rpm figure. The consumption of electricity, however, is reduced by 50%.

If the system in question only needs to be able to supply a flow that corresponds to 100% a few days in a year, while the average is below 80% of the rated flow for the remainder of the year, the amount of energy saved is even more than 50%.

The laws of proportionality

This figure describes the dependence of flow, pressure and power consumption on the rpm figure.

Q = Flow
 Q₁ = Rated flow
 Q₂ = Reducing flow

P = Power
 P₁ = Rated power
 P₂ = Reducing power

H = Pressure
 H₁ = Rated pressure
 H₂ = Reducing pressure

n = Speed regulation
 n₁ = Rated speed
 n₂ = Reducing speed

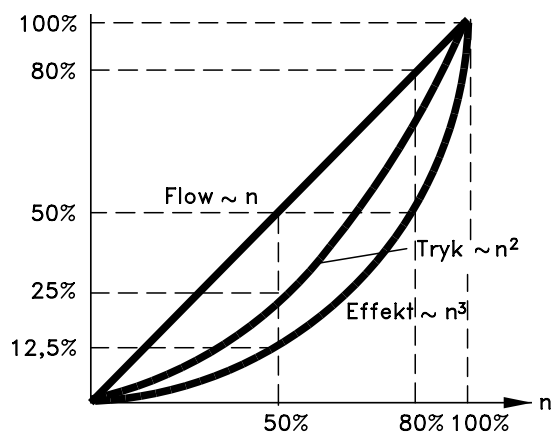

DANFOSS
 175HA208.10

Flow: $\frac{Q_1}{Q_2} = \frac{n_1}{n_2}$

Pressure: $\frac{H_1}{H_2} = \left(\frac{n_1}{n_2}\right)^2$

Power: $\frac{P_1}{P_2} = \left(\frac{n_1}{n_2}\right)^3$

■ Example with varying flow over 1 year

The example below is calculated on the basis of pump characteristics obtained from a pump data-sheet. (45 kW). The same examples of calculations can be used in the case of fan characteristics.

The result obtained is savings in excess of 50% at the

given flow distribution over a year, corresponding to 8,760 hours.

Typically, the example calculated below results in a pay-back period of one year - depending on the price per kWh and the price of the frequency converter.

Pump characteristics

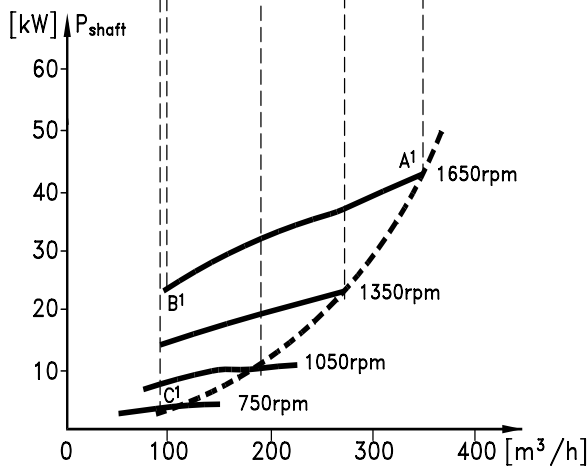
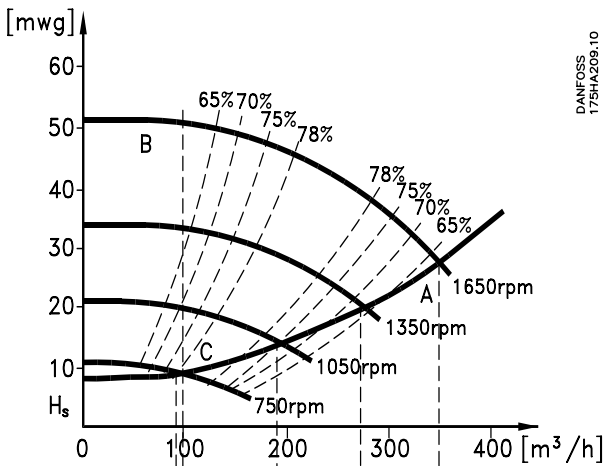

Energy savings

This figure compares flow regulation via valves and without speed control with flow regulation via a frequency converter.

$$P_{\text{shaft}} = P_{\text{shaft output}}$$

Flow distribution over 1 year

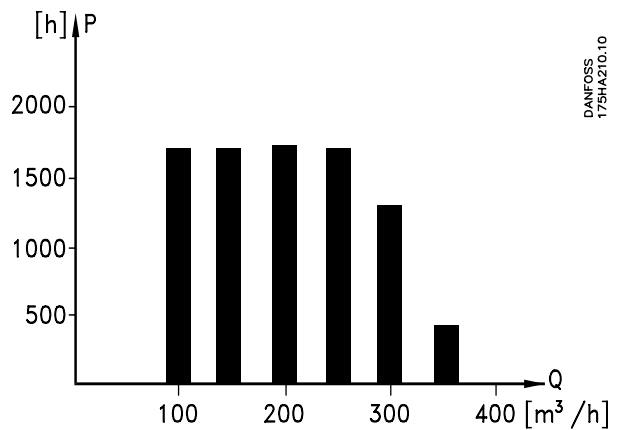

m3/t	Distribution		Valve regulation		Frequency converter control	
	%	Hours	Power A ₁ - B ₁	Consumption kWh	Power A ₁ - C ₁	Consumption kWh
350	5	438	42,5	18.615	42,5	18.615
300	15	1314	38,5	50.589	29,0	38.106
250	20	1752	35,0	61.320	18,5	32.412
200	20	1752	31,5	55.188	10,0	17.520
150	20	1752	28,0	49.056	6,5	11.388
100	20	1752	23,0	40.296	3,5	6.132
Σ	100	8760		275.064		124.173

■ Better regulation

If a frequency converter is used for regulating the flow or pressure of a system, improved regulation is obtained which can be adjusted very precisely. A frequency converter can vary the speed of the fan or pump infinitely, thereby obtaining infinitely variable control of flow and pressure.

Furthermore, a frequency converter can quickly regulate the speed of the fan or pump, so as to adapt it to new flow or pressure conditions in the system. More traditional, mechanical flow or pressure regulating systems tend to provide slow, inaccurate regulation if compared with that of the frequency converter.

■ Frequency converters generate less noise

If the speed of a fan is changed, the sound level changes, too. If the rpm figure is reduced by 50% from the rated rpm value, the sound level will go down by approx. 16 dB(A).

The formula is:

$$55 \log \left(\frac{n_1}{n_2} \right) = \text{dB(A)}$$

■ Simpler installation when using a frequency converter

A frequency converter can replace a traditional regulating system, in which mechanical dampers and valves are used for regulating flow or pressure. The great advantage involved in using a frequency converter is that the system becomes simpler, since a lot of the mechanical and electrical equipment is no longer required.

■ V-belts no longer required

In mechanical regulating systems, where the fan is driven by V-belts, it is necessary to change belt pulleys in order to adjust the fan speed to match the necessary maximum load. Using a frequency converter, the V-belts can be replaced by directly driven motors, whose speed is changed simply by means of the frequency converter.

The efficiency of the system improves and the entire installation takes up less space. There is no dust from the V-belt and less maintenance.

■ Regulating dampers and valves no longer required

Since the flow or pressure can be regulated by means of the frequency converter, no regulating dampers and valves are required in the system.

■ Cos φ compensation

Generally speaking, a frequency converter with a cos of 1 provides power factor correction for the cos φ of the motor, which means that there is no need to make allowance for the cos φ of the motor when sizing the power factor correction unit.

■ Star/delta starter or soft-starter not required

When larger motors are started, it is necessary in many countries to use equipment that limits the start-up current. In more traditional systems, a star/delta starter or soft-starter is widely used. Such motor starters are not required if a frequency converter is used.

As illustrated in the figure below, a frequency converter does not consume more than rated current.

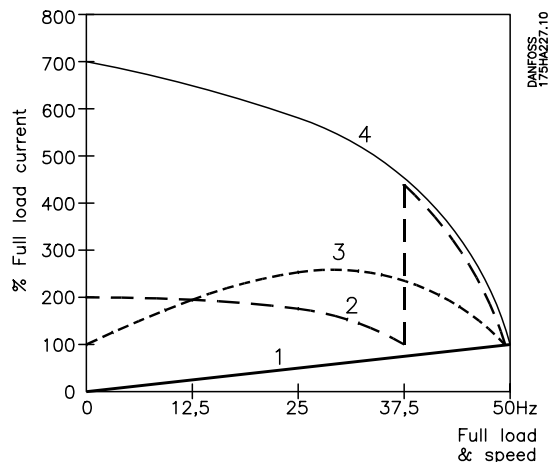

- 1 = VLT 6000 HVAC
- 2 = Star/delta starter
- 3 = Soft-starter
- 4 = Start directly on mains

■ Cost of using frequency converter not higher

The example on the following page shows that a lot of equipment is not required when a frequency converter is used. It is possible to calculate the cost of installing the two different systems. In the example on the following page, the two systems can be established at roughly the same price.

■ Without a frequency converter

The figure shows a fan system made in the traditional way.

- D.D.C. = Direct Digital Control
- E.M.S. = Energy Management System
- V.A.V. = Variable Air Volume
- Sensor P = Pressure
- Sensor T = Temperature

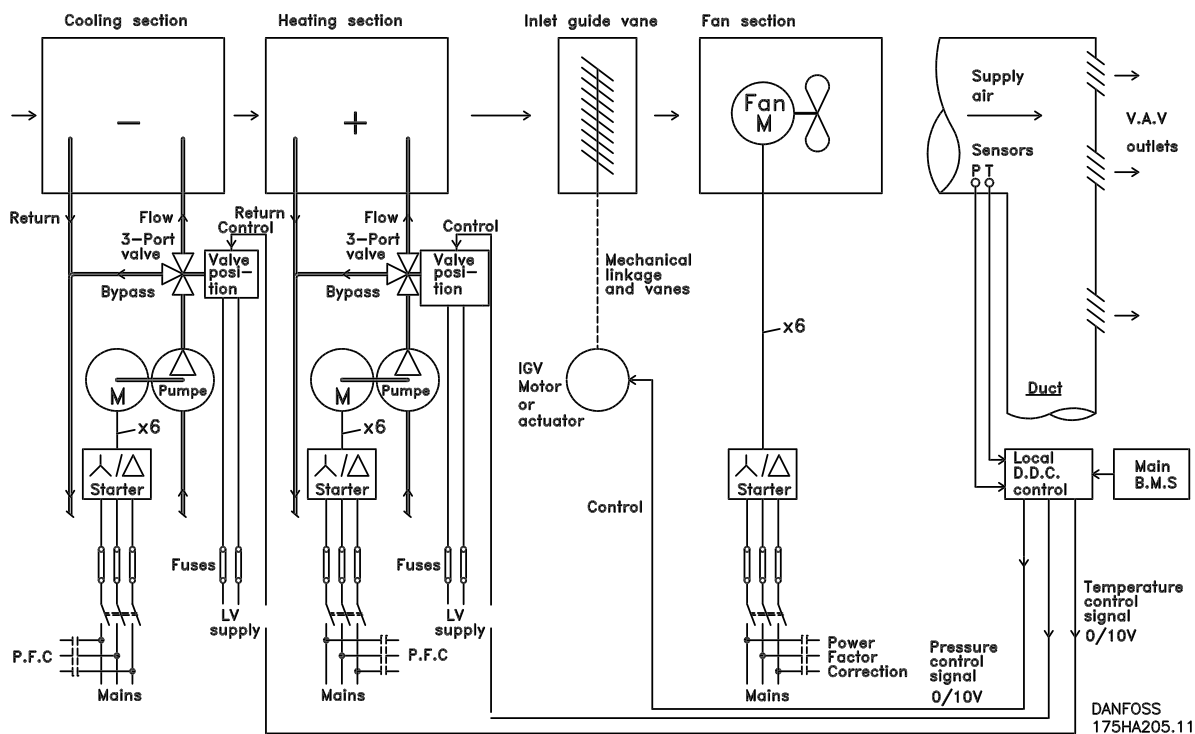

■ With a frequency converter

The figure shows a fan system controlled by VLT 6000 HVAC frequency converters.

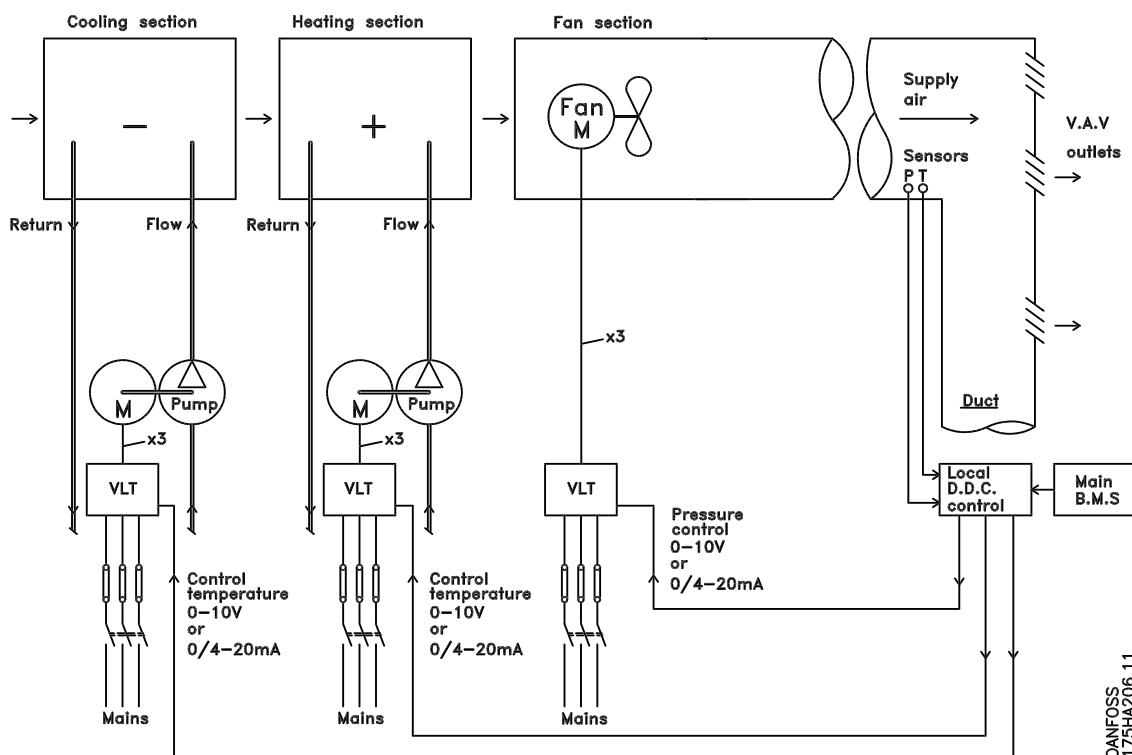

■ Control principle

A frequency converter rectifies AC mains voltage into DC voltage, after which the DC voltage is converted into an AC current with a variable amplitude and frequency.

The motor is thus supplied with variable voltage and frequency, which enables infinitely variable speed regulation of three phase, asynchronous standard motors.

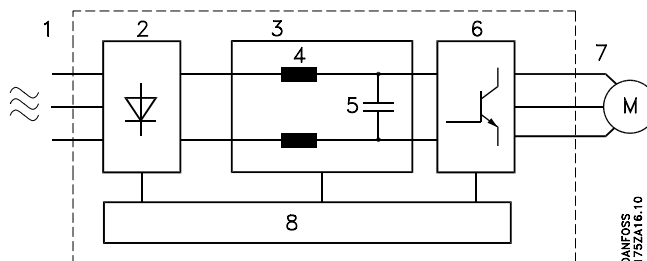
1. Mains voltage

3 x 200 - 240 V AC, 50 / 60 Hz
3 x 380 - 460 V AC, 50 / 60 Hz.

2. Rectifier

A three-phase rectifier bridge that rectifies AC into DC current.

3. Intermediate circuit

DC voltage = $\sqrt{2}$ x mains voltage [V].

4. Intermediate circuit coils

Smooth the intermediate circuit current and limit the repercussive effect of harmonic currents on the mains supply.

5. Intermediate circuit capacitors

Smooth the intermediate circuit voltage.

6. Inverter

Converts DC voltage into variable AC voltage with a variable frequency.

7. Motor voltage

Variable AC voltage, 10-100% of the supply voltage.

8. Control card

This is where to find the microprocessor that controls the inverter which generates the pulse pattern by which the DC voltage is converted into variable AC voltage with a variable frequency.

VVC^{PLUS} control principle

The VLT 6000 HVAC has an inverter system called VVC^{PLUS}, i.e. a further development of Voltage Vector Control (VVC). This principle is known from such units as Danfoss VLT 3500 HVAC.

The development of the VVC^{PLUS} principle is the result of a wish to maintain robust, sensorless regulation that is tolerant to different motor characteristics without motor derating being required.

VVC^{PLUS} controls an induction motor by energizing it with a variable frequency and a voltage that matches it. If the motor load is changed, the magnetisation and speed of the motor change too. Consequently, the motor current is measured continuously and the actual voltage requirement and slip of the motor are calculated from a motor model. Motor frequency and voltage are adjusted to ensure that the motor operating point remains optimised under varying conditions.

First and foremost, the current measurement and the motor model have been improved. The current is split into magnetising and torque-generating parts and provides for much better and quicker estimation of the actual motor loads. It is now possible to compensate much better for frequent load changes.

Good torque control properties, smooth transition to current limit operation and robust pull-out protection are ensured.

After automatic motor adaptation, VVC^{PLUS} will help to ensure extremely accurate motor control.

Because of the good load estimation achieved, an energy optimisation algorithm can be integrated - one that is effective regardless of the load characteristic.

Advantages of the V V C^{PLUS} control system:

- Good compensation for step loads
- Great tolerance towards varying motor characteristics
- Controlled transition from normal operation to current limit operation (and vice versa)
- Quick response from speed reference to full motor shaft torque
- Reliable pull-out torque protection throughout the speed range, also in the case of field weakening
- Torque control, comprising control of both the torque-generating and the magnetising component of the current

As standard, VLT 6000 HVAC comes with a number of integral components that would normally have to be acquired separately. These integral components are space-savers that simplify installation, since VLT 6000 HVAC fulfills most requirements without any additional components.

The use of a VLT 6000 HVAC offers the following additional advantages:

- All unit types are available with an integral RFI filter, complying with EN 55011 class 1-A in the case of a 150 m screened/armoured motor cable and EN 55011 class 1-B in the case of a screened/armoured motor cable up to 50 m long.
- Detachable LCP control panel with Hand-Off-Auto buttons and a graphics display of local speed.
- Automatic Motor Adaptation (AMA) ensures optimum motor performance.
- Integral PID regulator with option of connecting two feedback signals (in connection with zoning), as well as setting of two set-points.
- Sleep mode, which automatically turns the motor off, e.g. when there is no need for more pressure or flow in a system.

- The "flying start" function enables the unit to catch a rotating fan.
- Automatic ramp up/down to ensure that the VLT 6000 HVAC will not trip during acceleration or deceleration.
- All standard units have three integral, serial protocols - RS 485 FC protocol, Johnson's Metasys N2 and Landis/Staefa FLN. Communication option cards that can be connected are LonWorks, Profibus for the VLT 6000 HVAC.

Programmable control inputs and signal outputs in four Setups

VLT 6000 HVAC uses a digital technique which makes it possible to program the different control inputs and signal outputs and to select four different user-defined Setups for all parameters.

For the user, it is easy to program the required functions by means of the control panel on VLT 6000 HVAC or via serial communication.

Protection against mains interference

VLT 6000 HVAC is protected against the transients that occur in the mains supply, e.g. when switching power factor correction or if fuses blow when lightning strikes.

The rated motor voltage and full torque can be maintained all the way down to 10% undervoltage in the mains supply.

Minor interference on mains

Since as standard the VLT 6000 HVAC features intermediate circuit coils, there is only a small amount of harmonic mains supply interference. This ensures a good power factor (lower peak current), which reduces the load on the mains installation.

Advanced VLT protection

Current measurement on all three motor phases provides perfect protection of VLT 6000 HVAC against earthing and short-circuiting faults on the motor connection.

Constant monitoring of the three motor phases enables switching on the motor output, e.g. by means of a contactor.

Efficient monitoring of the three mains supply phases ensures that the unit trips in the case of phase failure. This avoids overloading the inverter and the capacitors in the intermediate circuit, which would dramatically reduce the service life of the frequency converter.

As standard, VLT 6000 HVAC features integral temperature protection. If a thermal overload occurs, this function cuts out the inverter.

Reliable galvanic isolation

In the VLT 6000 HVAC, all control terminals as well as terminals 1-5 (AUX relays) are supplied by or connected to circuits that comply with PELV requirements in relation to the mains potential.

Advanced motor protection

VLT 6000 HVAC features integrated electronic, thermal motor protection.

The frequency converter calculates the motor temperature on the basis of current, frequency and time.

As opposed to the traditional bimetallic protection, electronic protection takes account of the reduction in cooling at low frequencies that comes from reduced fan speed (motors with internal ventilation).

Thermal motor protection is comparable to a normal motor thermistor.

To obtain maximum protection against overheating of the motor if the motor is covered or blocked, or if the fan fails, a thermistor can be integrated and connected to the thermistor input of the frequency converter (terminals 53/54), see parameter 117 *Motor thermal protection*.

AEO - Automatic Energy Optimization

Normally, the U/f characteristics have to be set on the basis of the expected load at different frequencies. However, knowing the load at a given frequency in an installation is often a problem. This problem can be solved by using a VLT 6000 HVAC with its integral Automatic Energy Optimization (AEO), which ensures optimum energy utilization. All VLT 6000 HVAC units feature this function as a factory setting, i.e. it is not necessary to adjust the frequency converter U/f ratio in order to obtain maximum energy savings. In other frequency converters, the given load and voltage/frequency ratio (U/f) must be assessed to carry out correct setting of the frequency converter. Using Automatic Energy Optimization (AEO), you no longer need to calculate or assess the system characteristics of the installation, since Danfoss VLT 6000 HVAC units guarantee optimum, load-dependent energy consumption by the motor at all times.

The figure illustrates the working range of the AEO function, within which energy optimization is enabled.

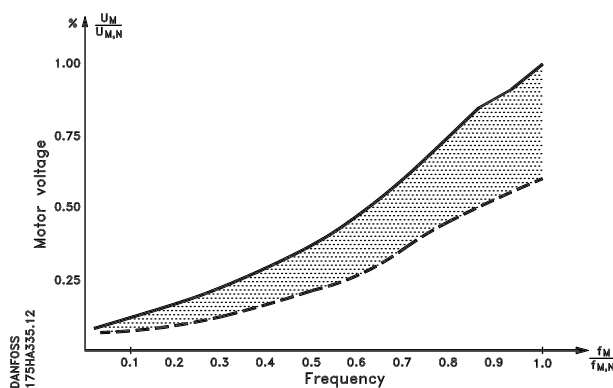

For torque characteristics, this function will be constantly active. If there is a major deviation from the optimum U/f ratio, the VLT frequency converter will quickly adjust itself.

Advantages of the AEO function

- Automatic energy optimization
- Compensation if an oversize motor is used
- AEO matches operations to daily or seasonal fluctuations
- Energy savings in a constant air volume system
- Compensation in the oversynchronous working range
- Reduces acoustic motor noise

■ PC software and serial communication

Danfoss offers various options for serial communication. Using serial communication makes it possible to monitor, programme and control one or several VLT 6000 HVAC from a centrally placed computer. For example, Danfoss offers an option card for Profibus. In addition, all VLT 6000 HVAC have an RS 485 port as standard, which enables them to communicate e.g. with a PC. A programme entitled VLT Software Dialog is available for this purpose.

VLT Software Dialog comes in three modules and - as a minimum - contains the programmes included in the Basic module.

The Basic module covers:



TEST RUN

is used for controlling and commissioning of a frequency converter, including:

- setting of reference value,
- simultaneous display of selected parameters in graphs,
- option of DDE link, e.g. to a spreadsheet.



PARAMETER SETUP

is used for setting up and transferring parameter sets, including:

- setting of frequency converter parameters,
- parameter sets can be obtained from and copied to a frequency converter,
- documentation/print-out of the Setup including diagrams.



HISTORY

provides information about the different stages of development of the VLT Software dialogue.



BUS ADDRESS SETUP

is only used for addressing the VLT FCM.

Logging module covers:



LOGGING

is used for collecting and displaying historical or real-time operating data.

- graphical representation of selected parameters from several frequency converters,
- collection of log data to file,
- option of DDE link e.g. to a spreadsheet.



MODEM SETUP

is used for setting up the frequency converter modem.

- sets the frequency converter modem via the communication port of the PC.

The template module covers:



TEMPLATE SETUP

is used for setting up template files for

PARAMETER SETUP:

- the template file functions as a mask that limits the number of accessible parameters when a parameter file is to be made or edited in PARAMETER SETUP,
- the template file may contain preset values for the parameters of the frequency converter.

NB!



The logging and template module calls for a Basic module to be installed on the same PC.

The guided tour covers:



GUIDED TOUR

offers a demonstration of the VLT Software Dialog programme.

■ CE-labelling**What is CE-labelling ?**

The purpose of CE-labelling is to avoid technical obstacles to trade within EFTA and the EU. The EU has introduced the CE-label as a simple way of showing whether a product complies with the relevant EU directives. The CE-label says nothing about the quality or specifications of a product. Three EU directives relate to frequency converters:

- **The machine directive (89/392/EEC)**

All machines with critical, moving parts are comprised by the machine directive which came into force on 1 January 1995. Since a frequency converter is largely electrical by function, it does not fall under the machine directive. However, if a frequency converter is supplied for use in a machine, we provide information about the safety aspects relating to the frequency converter. We do that by means of a manufacturer's declaration.

- **The low voltage directive (73/23/EEC)**

Frequency converters must be CE-labelled in accordance with the low voltage directive which came into force on 1 January 1997. This directive applies to all electrical equipment and units used in the 50-1000 V AC and 75-1500 V DC voltage ranges. Danfoss provides its units with CE-labels in accordance with the directive and issues declarations of conformity upon request.

- **The EMC directive (89/336/EEC)**

EMC is short for electromagnetic compatibility. The presence of electromagnetic compatibility means that the mutual interference between different components/appliances is so small that the functioning of the appliances is not affected. The EMC directive came into force on 1 January 1996. In accordance with the directive, Danfoss CE-labels its products and issues a declaration of conformity upon request.

To help ensure that your installation is EMC-correct, the manual provides detailed instructions for installation. Furthermore, we specify which norms that are complied with by which of our products. We offer the filters that can be seen from the specifications and gladly provide other types of assistance that can help you obtain the best possible EMC result.

In most cases the VLT frequency converter is used by professionals of the trade as a complex component forming part of a larger appliance, system or installation. It must be noted that the responsibility for the final EMC properties of the appliance, system or installation rests with the installer.

■ **Application examples**

The next few pages give typical examples of applications within HVAC.

If you would like to receive further information about a given application, please ask your Danfoss supplier for an information sheet that gives a full description of the application.

Variable Air Volume	page 18
Ask for <i>The Drive to...Improving Variable Air Volume Ventilation systems</i>	MN.60.A1.02
Constant Air Volume	page 19
Ask for <i>The Drive to...Improving Constant Air Volume Ventilation systems</i>	MN.60.B1.02
Cooling Tower Fan	page 20
Ask for <i>The Drive to...Improving fan control on cooling towers</i>	MN.60.C1.02
Condenser pumps	page 21
Ask for <i>The Drive to...Improving condenser water pumping systems</i>	MN.60.F1.02
Primary pumps	page 22
Ask for <i>The Drive to...Improve your primary pumping in primay/secondary pumping systems</i>	MN.60.D1.02
Secondary pumps	page 23
Ask for <i>The Drive to...Improve your secondary pumping in primay/secondary pumping systems</i>	MN.60.E1.02

■ Variable Air Volume

VAV or Variable Air Volume systems, are used to control both the ventilation and temperature to satisfy the requirements of a building. Central VAV systems are considered to be the most energy efficient method to air condition buildings. By designing central systems instead of distributed systems, a greater efficiency can be obtained. The efficiency comes from utilizing larger fans and larger chillers which have much higher efficiencies than small motors and distributed air-cooled chillers. Savings are also seen from the decreased maintenance requirements.

■ The new standard

While dampers and IGVs work to maintain a constant pressure in the ductwork, a VLT frequency converter solution saves much more energy and reduces the complexity of the installation. Instead of creating an artificial pressure drop or causing a decrease in fan efficiency, the VLT frequency converter decreases the speed of the fan to provide the flow and pressure required by the system. Centrifugal devices such as fans behave according to the centrifugal laws. This means the fans decrease the pressure and flow they produce as their speed is reduced. Their power consumption is thereby significantly reduced. The return fan is frequently controlled to maintain a fixed difference in airflow between the supply and return. The advanced PID controller of the VLT 6000 HVAC can be used to eliminate the need for additional controllers.

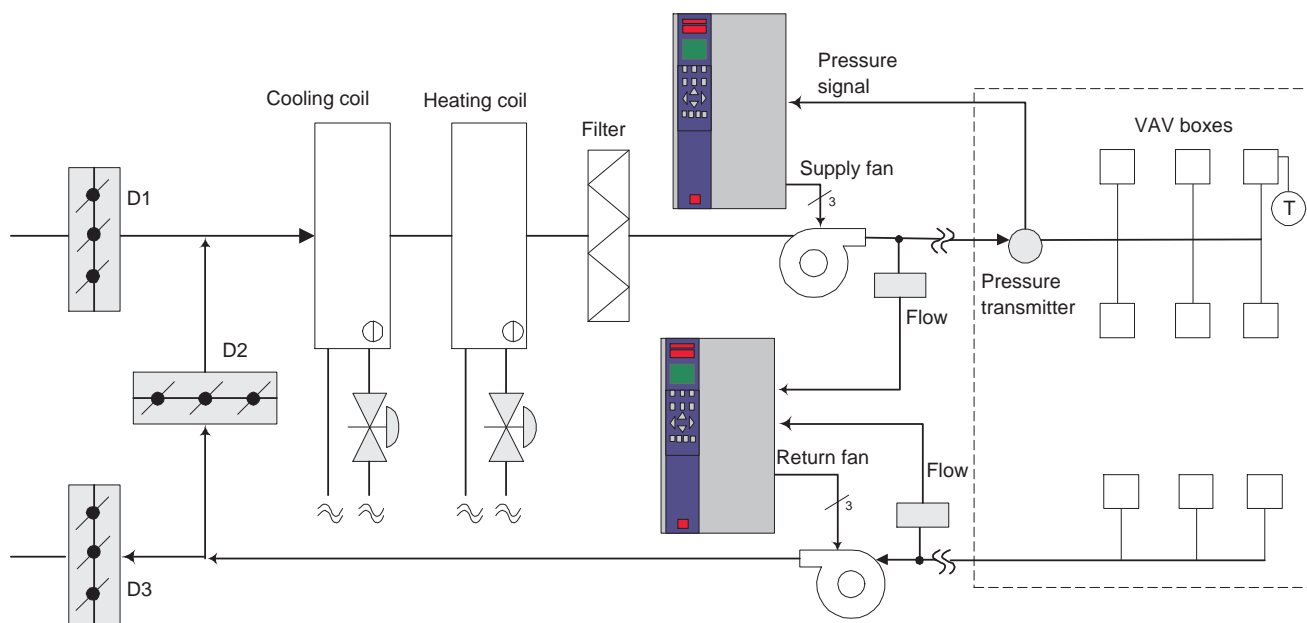

■ **Constant Air Volume**

CAV, or Constant Air Volume systems are central ventilation systems usually used to supply large common zones with the minimum amounts of fresh tempered air. They preceded VAV systems and therefore are found in older multi-zoned commercial buildings as well. These systems preheat amounts of fresh air utilizing Air Handling Units (AHUs) with a heating coil, and many are also used to air condition buildings and have a cooling coil. Fan coil units are frequently used to assist in the heating and cooling requirements in the individual zones.

■ **The new standard**

With a VLT frequency converter, significant energy savings can be obtained while maintaining decent control of the building. Temperature sensors or CO2 sensors can be used as feedback signals to VLT frequency converters. Whether controlling temperature, air quality, or both, a CAV system can be controlled to operate based on actual building conditions. As the number of people in the controlled area decreases, the need for fresh air decreases. The CO2 sensor detects lower levels and decreases the supply fans speed. The return fan modulates to maintain a static pressure setpoint or fixed difference between the supply and return air flows.

With temperature control, especially used in air conditioning systems, as the outside temperature varies as well as the number of people in the controlled zone changes, different cooling requirements exist. As the temperature decreases below the setpoint, the supply fan can decrease its speed. The return fan modulates to maintain a static pressure setpoint. By decreasing the air flow, energy used to heat or cool the fresh air is also reduced, adding further savings.

Several features of Danfoss HVAC dedicated VLT frequency converter, the VLT 6000 HVAC can be utilized to improve the performance of your CAV system. One concern of controlling a ventilation system is poor air quality. The programmable minimum frequency can be set to maintain a minimum amount of supply air regardless of the feedback or reference signal. The VLT frequency converter also includes a two zone, 2 setpoint PID controller which allows monitoring both temperature and air quality. Even if the temperature requirement is satisfied, the drive will maintain enough supply air to satisfy the air quality sensor. The controller is capable of monitoring and comparing two feedback signals to control the return fan by maintaining a fixed differential air flow between the supply and return ducts as well.

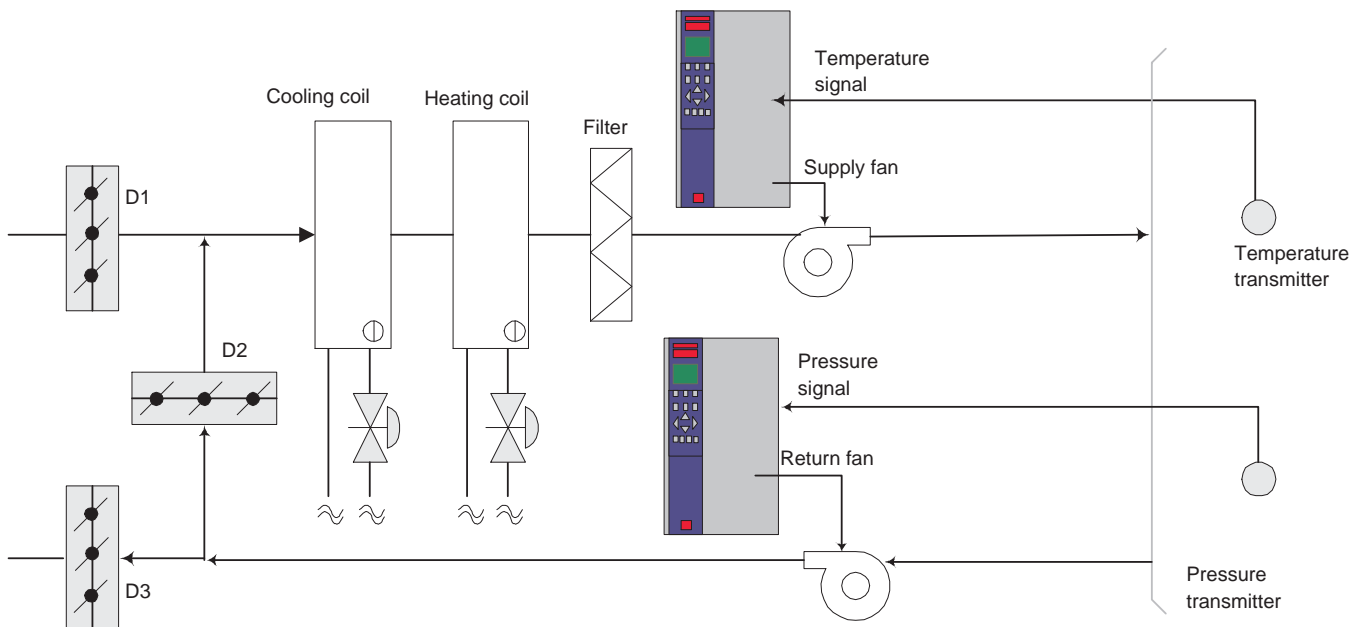

■ **Cooling Tower Fan**

Cooling Tower Fans are used to cool condenser water in water cooled chiller systems. Water cooled chillers provide the most efficient means of creating chilled water. They are as much as 20% more efficient than air cooled chillers. Depending on climate, Cooling towers are often the most energy efficient method of cooling the condenser water from chillers. They cool the condenser water by evaporation. The condenser water is sprayed into the cooling tower onto the cooling towers “fill” to increase its surface area. The tower fan blows air through the fill and sprayed water to aid in the evaporation. Evaporation removes energy from the water dropping its temperature. The cooled water collects in the cooling towers basin where it is pumped back into the chillers condenser and the cycle is repeated.

■ **The new standard**

With a VLT frequency converter, the cooling towers fans can be controlled to the required speed to maintain the condenser water temperature. VLT frequency converters can also be used to turn the fan on and off as needed.

Several features of Danfoss HVAC dedicated drive, the VLT 6000 HVAC can be utilized to improve the performance of your cooling tower fans application. As the cooling tower fans drop below a certain speed, the effect the fan has on cooling the water becomes small. Also, when utilizing a gear-box to VLT frequency converter the tower fan, a minimum speed of 40-50% may be required. The customer programmable minimum frequency setting of the VLT is available to maintain this minimum frequency even as the feedback or speed reference calls for lower speeds.

Also as a standard feature, you can program the VLT frequency converter to enter a “sleep” mode and stop the fan until a higher speed is required. Additionally, some cooling tower fans have undesirable frequencies that may cause vibrations. These frequencies can easily be avoided by programming the bypass frequency ranges in the VLT frequency converter.

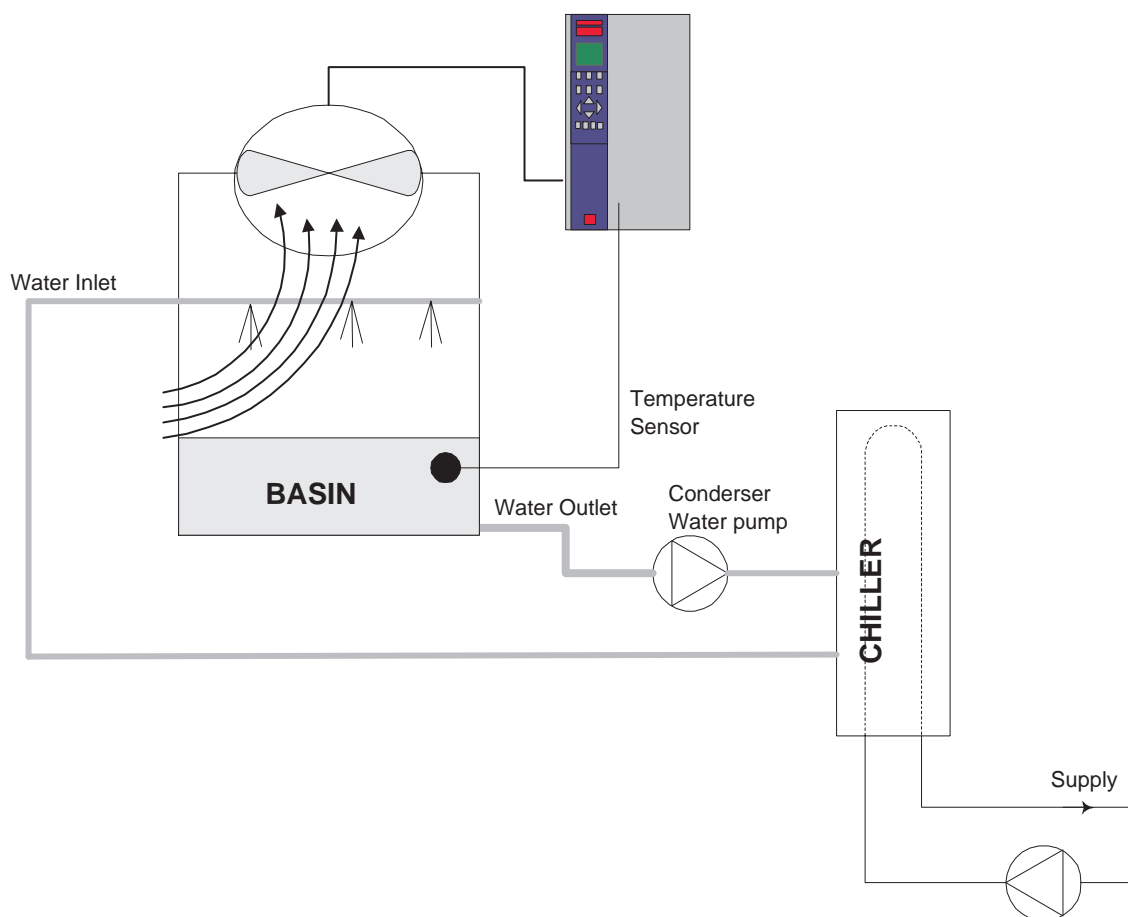

■ **Condenser pumps**

Condenser Water pumps are primarily used to circulate water through the condenser section of water cooled chillers and their associated cooling tower. The condenser water absorbs the heat from the chillers condenser section and releases it into the atmosphere in the cooling tower. These systems are used to provide the most efficient means of creating chilled water, they are as much as 20% more efficient than air cooled chillers.

■ **The new standard**

VLT frequency converters can be added to condenser water pumps instead of balancing the pumps with a throttling valve, to control the water temperature instead of tower fans, or to control the water temperature in addition to controlling the tower fans.

Pump control is used in conjunction with fan control to control the water temperature in free cooling applications or when the cooling towers are significantly oversized. In some circumstances the environment itself causes the water to become too cool even when the fan is off. The VLT frequency converter controlled pump maintains the appropriate temperature by increasing or decreasing the discharge pressure and flow rate. The decreased pressure at the spray nozzle in the cooling tower decreases the surface area of the water exposed to the air. Cooling is decreased and the design temperature can be maintained in periods of low loads.

Using a VLT frequency converter instead of a throttling valve simply saves the energy that would have been absorbed by the valve. This can amount to savings of 15-20% or more. VLT frequency converters are used to control the water temperature instead of controlling the cooling tower fans when it is more convenient to access the pumps than the tower fans.

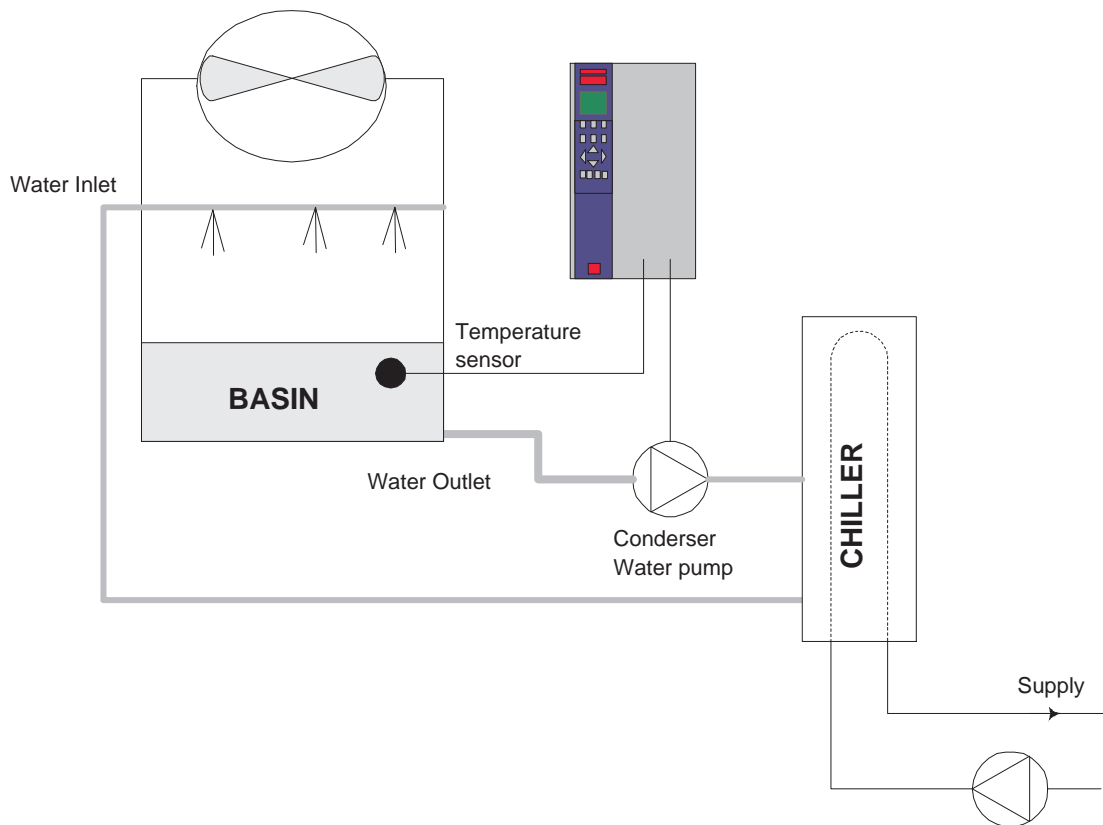

■ **Primary pumps**

Primary pumps in a primary/secondary pumping system can be used to maintain a constant flow through devices that encounter operation or control difficulties when exposed to variable flow. The primary/secondary pumping technique decouples the “primary” production loop from the “secondary” distribution loop. This allows devices such as chillers to obtain constant design flow and operate properly while allowing the rest of the system to vary in flow.

As the evaporator flow rate decreases in a chiller, the chilled water begins to become over-chilled. As this happens, the chiller attempts to decrease its cooling capacity. If the flow rate drops far enough, or too quickly, the chiller cannot shed its load sufficiently and the chiller’s low evaporator temperature safety trips the chiller requiring a manual reset. This situation is common in large installations especially when two or more chillers in parallel are installed if primary/secondary pumping is not utilized.

■ **The new standard**

Depending on the size of the system and the size of the primary loop, the energy consumption of the primary loop can become substantial. A VLT frequency converter can be added to the primary system, to replace the throttling valve and/or trimming of the impellers, leading to reduced operating expenses. Two control methods are common:

The first method uses a flow meter. Because the desired flow rate is known and is constant, a flow meter can be installed at the discharge of each chiller can be used to control the pump directly. Using the built-in PID controller, the VLT frequency converter will always maintain the appropriate flow rate, even compensating for the changing resistance in the primary piping loop as chillers and their pumps are staged on and off.

The other method is local speed determination. The operator simply decreases the output frequency until the design flow rate is achieved.

Using a VLT frequency converter to decrease the pumps speed is very similar to trimming the pumps impeller, except it doesn’t require any labor and the pumps efficiency remains higher. The balancing contractor simply decreases the speed of the pump until the proper flow rate is achieved and leaves the speed fixed. The pump will operate at this speed any time the chiller is staged on. Because the primary loop doesn’t have control valves or other devices that can cause the system curve to change and the variance due to staging pumps and chillers on and off is usually small, this fixed speed will remain appropriate. In the event the flow rate needs to be increased later in the systems life, the VLT frequency converter can simply increase the pumps speed instead of requiring a new pump impeller.

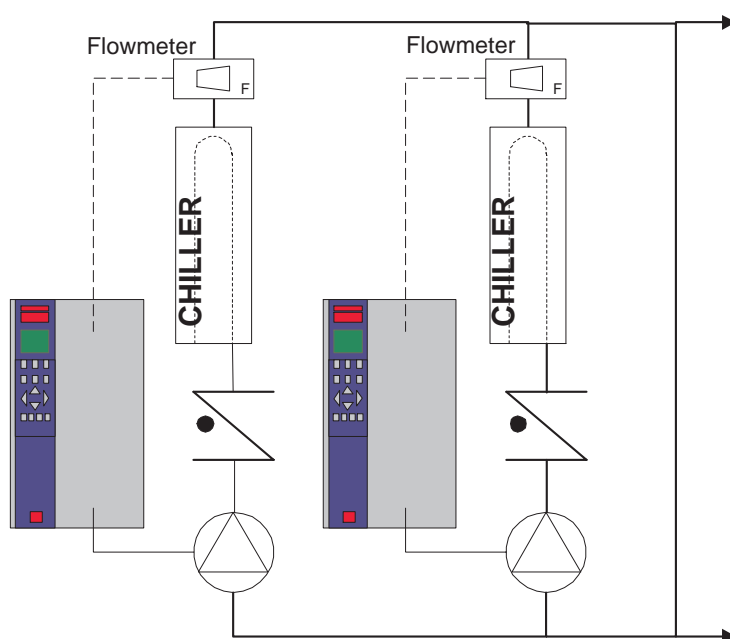

■ Secondary pumps

Secondary pumps in a primary/secondary chilled water pumping system are used to distribute the chilled water to the loads from the primary production loop. The primary/secondary pumping system is used to hydraulically decouple one piping loop from another. In this case, the primary pump is used to maintain a constant flow through the chillers while allowing the secondary pumps to vary in flow, increase control and save energy.

If the primary/secondary design concept is not used and a variable volume system is designed, when the flow rate drops far enough or too quickly, the chiller cannot shed its load properly. The chiller's low evaporator temperature safety then trips the chiller requiring a manual reset. This situation is common in large installations especially when two or more chillers in parallel are installed.

■ The new standard

While the primary-secondary system with two-way valves improves energy savings and eases system control problems, the true energy savings and control potential is realized by adding VLT frequency converters.

With the proper sensor location, the addition of VLT frequency converters allows the pumps to vary their speed to follow the system curve instead of the pump curve.

This results in the elimination of wasted energy and eliminates most of the over-pressurization the two-way valves can be subjected to.

As the monitored loads are satisfied, the loads two-way valves close down. This increases the differential pressure measured across the load and two-way valve. As this differential pressure starts to rise, the pump is slowed to maintain the control head also called setpoint value. This setpoint value is calculated by summing the pressure drop of the load and two way valve together under design conditions.



NB!

Please note that when running multiple pumps in parallel, they must run at the same speed to maximize energy savings, either with individual dedicated drives or one drive running multiple pumps in parallel.

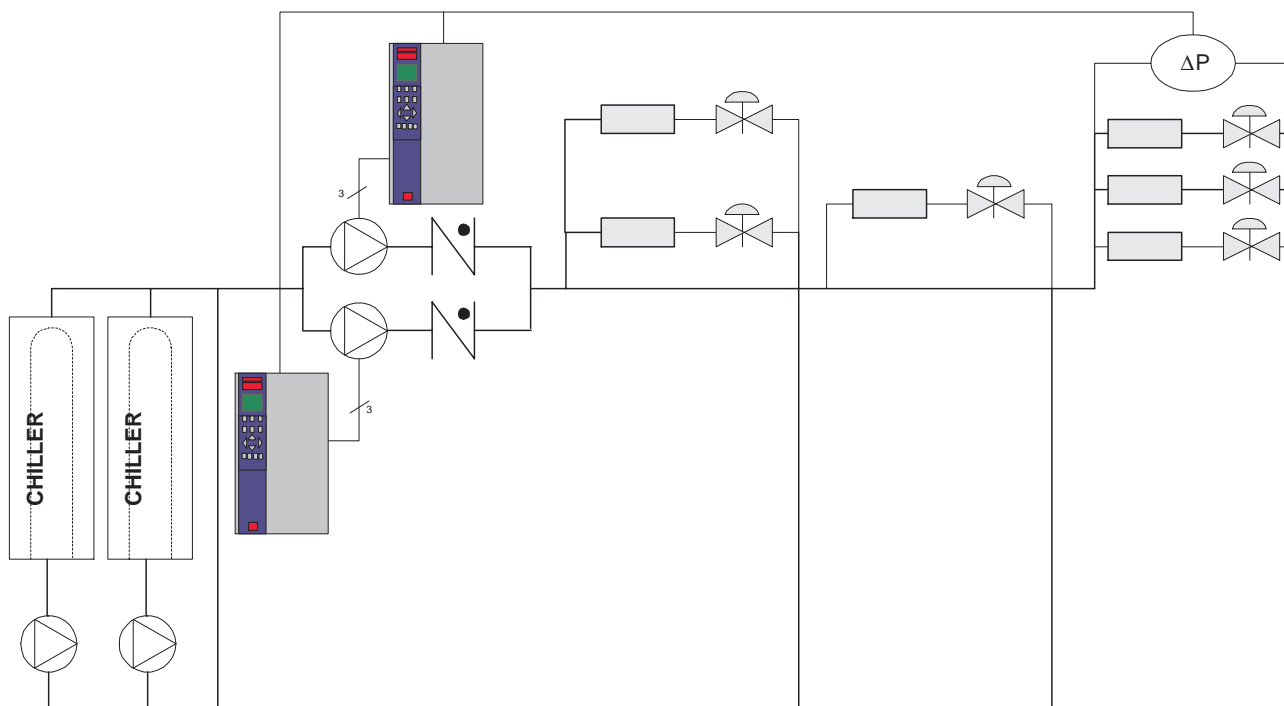

■ Specification text

The following is a proposal for a HVAC frequency converter specification text that can be supplied with tender material.

■ Part 1 General1.01 Section Includes

A. This section covers the requirements necessary to furnish and install frequency converters.

1.02 Related Work

A. This section shall be used in conjunction with the following other specifications and related Contract Documents to establish the total requirements for frequency converters:

1) Section 16000 - Basic Electrical Requirements

B. In the event of conflicts regarding frequency converter requirements between this section and any other section, the provision of this section shall govern.

1.03 References

Each frequency converter shall be designed and manufactured in accordance with the current edition of the following European and international standards and directives:

- A. EN 55011 - Limits and methods of measurement of radio disturbance characteristics (EMC Emission)
- B. EN 50178 - Electronic equipment for use in Power Installations
- C. EN 61800-3 - Adjustable speed electrical power drive systems - Part 3: EMC product standard
- D. EN 61000-3-2 - Limits for harmonic current emissions (equipment input current below 16 A per phase)
- E. prEN 61000-3-4 - Limits for harmonic current emissions (equipment input current above 16 A per phase)
- F. ENV 50140 - EMC/Radiated radio frequency electrical field (simulation of impact from GSM telephones)
- G. EMC Directive 89/336/EEC
- H. Low Voltage Directive 73/23/EEC
- I. EN 50082-2 - Generic Immunity, Industry
- J. EN/IEC 61000-4-2 - ElectroStatic Discharge (EMC Immunity)
- K. EN/IEC 61000-4-3 - Radiated electromagnetic field (EMC Immunity)

- L. EN/IEC 61000-4-4 - Burst (EMC Immunity)
- M. EN/IEC 61000-4-5 - Surge (EMC Immunity)
- N. EN/IEC 61000-4-6 - Cable born HF (EMC Immunity)
- O. VDE 0160 class W2 test pulse - Mains transients (EMC Immunity)
- P. UK Electricity Council Recommendation G5/3 Stage 2 (EMC Emission)
- Q. IEEE 519: 1992 - Harmonic Control in Electrical Power Systems
- R. UL 508
- S. US National Electric Code (NEC)
- T. Canadian Underwriters Laboratory (C-UL).

1.04 Design Criteria

- A. The frequency converter shall be designed for HVAC applications.
- B. The frequency converter shall be of the pulse width modulated voltage vector control type.
- C. The frequency converter shall be able to operate any asynchronous AC motor with a variable torque load.

1.05 Regulatory Requirements

- A. The frequency converters must be CE marked in accordance with the EMC Directive 89/336/EEC and the Low Voltage Directive 73/23/EEC.
- B. A Manufacturers Declaration must be issued in accordance with the Machine Directive 89/392/EEC.
- C. Conducted Radio Frequency Interference (RFI) shall be in accordance with EN 55011 Group 1 Class B with built-in RFI filters.
- D. The Total Harmonic Voltage Distortion in the electrical power system shall not exceed 5% at the Point of Common Coupling (transformer secondary side).
- E. The frequency converter immunity shall be in accordance with EN 50082-2.
- F. The manufacturer shall be certified in accordance with ISO 14001: 1996 Environmental Management Systems.

1.06 Quality Assurance

- A. The frequency converters shall be manufactured in accordance with ISO 9001: 1994 Quality Systems.
- B. To ensure quality and minimize failures at the jobsite, every frequency converter shall be tested by the manufacturer. The frequency converter shall operate a dynamometer at full load and the load and speed shall be cycled during the test.
- C. All optional features shall be functionally tested at the factory for proper operation.

1.07 Submittals

- A. Submit manufacturer's performance data including:
 - 1) dimensional drawings
 - 2) power circuit diagrams
 - 3) installation and maintenance manuals
 - 4) warranty description
 - 5) frequency converter's full load ampere rating
 - 6) UL certification agency file numbers
 - 7) catalog information
- B. The specification lists the minimum frequency converter performance requirements for this project. Each supplier shall list any exceptions to the specification. If no departures from the specification are identified, the supplier shall be bound by the specification.
- C. The frequency converter manufacturer shall carry out a harmonics study to determine compliance with the standards listed under *1.03 References* at the Point of Common Coupling prior to commencement of contract. Data necessary to perform the study will be made available to the manufacturer.

2.01 Manufacturers

Danfoss VLT® 6000 HVAC
Graham VLT® 6000 Series

2.02 General

- A. Furnish complete frequency converters as specified herein for the fans and pumps designated on the drawing schedules to be variable speed. All standard and optional features shall be included within the frequency converter enclosure, unless otherwise specified.
- B. All drive adjustments and programming shall be capable of being stored in non-volatile memory (EEPROM).
- C. Operating frequency shall be limited to zero to 120 Hz
- D. Active current limit function to provide nominal 110 percent torque for 1 minute.

2.03 Mechanical

- A. Frequency converters shall be housed in a metal IP 54 enclosure in accordance with IEC 529.

2.04 Electrical

- A. The frequency converter shall convert incoming fixed frequency three-phase AC power into a variable frequency and voltage for controlling the speed of three phase AC motors. The motor current shall closely approximate a sine wave. Motor voltage shall be varied with frequency to maintain desired motor magnetization current suitable for centrifugal pump and fan control.
- B. An advanced sine wave approximation and voltage vector control shall be used to allow operation at rated motor shaft output at nominal speed with no derating. This voltage vector control shall minimize harmonics to the motor to increase motor efficiency and life.

■ Part 2 Products

- C. The frequency converter shall include Automatic Motor Adaptation (AMA), to optimize motor performance, improve start capabilities and compensate for motor cable variances. AMA shall be carried out at motor standstill with no need for detaching the load from the motor.
- D. The frequency converter and options shall be tested to ANSI/UL Standard 508. The complete frequency converter, including all specified options, shall be listed by a nationally recognized testing agency such as UL, C-UL, ETL or CSA.
- E. The frequency converter shall have a DC link reactor integrated to minimize power line harmonics. There shall be reactors in both the positive and negative rails. Frequency converters without a DC link reactor shall provide 3% impedance AC line reactors.
- F. The frequency converter's full load amp rating shall meet or exceed NEC Table 430-150.
- G. The frequency converter shall be able to provide full rated output current continuously, 110% of rated current for 60 seconds and 160% torque for up to 5 seconds for high inertia and high friction loads.
- H. An automatic energy optimization feature shall be provided as standard in the frequency converter. This feature shall reduce voltages when the motor is lightly loaded and minimise the motor losses.
- I. For additional energy savings the frequency converter must be able to turn itself off, when operation does not serve a purpose as determined by the control signal. To prevent the frequency converter from turning on and off all the time, a Boost setpoint must be selectable.
- J. The frequency converter fan must automatically turn off at low temperatures.
- K. Unlimited output power circuit switching must be possible without the need for control circuit interlocking and without causing damage to the frequency converter.

2.05 Protective Features

- A. Class 20 I²t electronic motor overload protection for single motor applications and thermal-mechanical overloads for multiple motor applications.
- B. Protection against input transients, loss of AC line phase, short circuit, ground fault, overvoltage, undervoltage, frequency converter overtemperature and motor overtemperature. The frequency converter shall display all faults in plain text. Codes are not acceptable.
- C. Protection of frequency converter from sustained power or phase loss. The frequency converter shall incorporate a 300 msec control power loss ride through to eliminate nuisance tripping.
- D. The frequency converter shall incorporate a motor preheat circuit to keep the motor warm and prevent condensation build up in the stator.
- E. The frequency converter shall incorporate a run permissive function, which will exports a "run permissive standby" signal to a digital output, when a start signal is applied to the frequency converter. The frequency converter must not start until it receives a "ready" signal from an external contact.
- F. The frequency converter shall incorporate 4 skip frequencies with adjustable bandwidth, to prevent mechanical resonances from destroying the equipment.
- G. To prevent breakdown of the motor winding insulation, the U_{PEAK} must be below 1000 V. The supplier shall include with the quotation the U_{PEAK} values of the frequency converter.
- H. The frequency converter shall catch a rotating motor operating forward or reverse up to full speed to prevent nuisance tripping.
- I. A thermistor input must be available in the frequency converter.
- J. The frequency converter shall incorporate constant torque start to prevent nuisance tripping.
- K. Automatic adjustment of the ramp time, to prevent tripping, must be incorporated in the frequency converter.

- L. Autoderating of the maximum drive current shall be incorporated in the frequency converter, to allow continued operation at reduced speed, in case of an overtemperature, phase loss or mains imbalance, without damaging the frequency converter.
- M. Full galvanic isolation with suitable potential separation from the power sources to ensure compliance with the PELV requirements of EN 50178.

2.06 Control

- A. Hand/Off/Auto selector switches shall be provided on the keypad to start and stop the frequency converter. It must be possible to select local and remote reference independent of Hand/Off/Auto. The local speed reference must be adjustable from the keypad.
- B. Digital manual speed control. Potentiometers are not acceptable.
- C. Provide a 24 V DC, 40 mA max, output signal to indicate that the frequency converter is in Auto mode.
- D. Lockable, alphanumeric backlit display keypad can be remotely mounted up to 3 meters away.
- E. It must be possible to read 4 operating parameters on the display at the same time.
- F. It shall be possible to upload the frequency converter settings in the keypad, to allow programming of other drives through downloading of parameters. Upload/download must be possible between any frequency converter size.
- G. Frequency converters up to 200 kW shall use the same control panel.
- H. Displays shall be available in 9 languages including English, Spanish, German and French.
- I. A red FAULT light, a yellow WARNING light and a green POWER-ON light shall be provided.
- J. A Quick Setup menu with preset parameters shall be provided for easy pre-commissioning.
- K. It must be possible to connect an external key-lock to the frequency converter, to prevent unauthorised programming.
- L. The frequency converter shall be equipped with a RS 485 serial communication port and be supplied with software to display all monitoring, fault, alarm and status signals. The software shall allow parameter changes to be made to the frequency converter settings as well as storage of each controller's operating and Setup parameters. The protocol must be selectable. Choices must include Danfoss FC protocol, Johnson Controls Metasys N2, Landis-Staefa FLN.
- M. A LonMark certified option must be available for the frequency converter, to secure easy implementation in a LonWorks network.
- N. It must be possible to program a text string in the frequency converter display.
- O. PID controller shall be standard in the unit. Programming must be done in process units (including: Pa, MPa, mbar, inWG, ftWG, m³/h, m³/s, GPM, CFM, °C and °F).
- P. It shall be possible to program a feedback conversion, such that the frequency converter interprets a pressure as a flow. This must be accomplished by a automatic conversion of the squared pressure signal into a linear flow signal.
- Q. A low pass filter must be supplied with the PID controller.
- R. The PID controller shall be able to accept two feedback signals and two setpoints. Response to the setpoint/feedback differences must be programmable.
- S. It must be possible to increase/decrease speed in response to digital signals.
- T. An elapsed time meter and kWh meter shall be provided.
- U. The following displays shall be accessible from the control panel in actual units: Local and Remote Reference Signal Percent, Output Frequency, Output Amps, Motor HP, Motor kW, kWh, Output Voltage, No Load Warning, DC Bus Voltage, frequency converter Temperature (in °C) and Motor Speed in engineering units per application (in percent speed, RPM).

- V. The frequency converter will sense the loss of load and signal a no load/broken belt warning or fault.
- W. The frequency converter shall store in memory the last 10 faults and record all operational data.
- X. Eight programmable digital inputs shall be provided for interfacing with the system's control and safety interlock circuitry.
- Y. Two programmable relay outputs shall be provided for remote indication of frequency converter status.
- Z. Three programmable analog inputs shall be provided and shall accept a direct-or-reverse acting signal. Analog reference inputs accepted shall include 0-10 V DC, 0-20 mA and 4-20 mA.
- AA. Two programmable analog outputs shall be provided for indication of frequency converter status. These outputs shall be programmable for output speed, voltage, frequency, amps and kW.
- BB. Under fire mode conditions the frequency converter shall automatically default to a preset speed via a normally open (NO) contact.
- F. 4 Setups must be provided to allow changing between different operating modes, such as from normal operation to fire mode.
- G. Eight acceleration and eight deceleration ramps shall be provided. The shape of these curves shall be adjustable.
- H. Four current limit settings shall be provided.
- I. If the frequency converter trips on one of the following conditions, the frequency converter shall be programmable for automatic or manual reset: undervoltage, overvoltage, current limit, inverter overload and motor overload.
- J. The number of restart attempts shall be selectable from 0 through 20 and the time between attempts shall be adjustable from 0 through 600 seconds.

2.07 ADJUSTMENTS

- A. The frequency converter shall have an adjustable switching frequency of 2 to 10 kHz.
- B. It must be possible for the frequency converter to automatically adjust the switching frequency as high as possible, without derating, to reduce acoustic noise in the motor.
- C. The voltage/frequency ratio shall automatically be adjusted to minimize motor losses.
- D. A variable torque curve for parallel motors shall be available. The start voltage must be adjustable.
- E. It must be possible to obtain 160% break away torque for at least 0.5 sec.

2.08 BYPASS

- A. Where indicated on the drawings, the frequency converter is to be provided with a manual bypass consisting of a door interlocked main fused disconnect pad lockable in the off position, a built-in motor starter and a four position DRIVE/OFF/LINE/TEST switch controlling three contactors. In the DRIVE position, the motor is operated at an adjustable speed from the frequency converter. In the OFF position, the motor and frequency converter are disconnected. In the LINE position, the motor is operated at full speed from the AC power line and power is disconnected from the frequency converter, so that service can be performed. In the TEST position, the motor is operated at full speed from the AC line power. This allows the frequency converter to be given an operational test while continuing to run the motor at full speed in bypass. Customer supplied normally closed dry contact shall be interlocked with the frequency converters safety trip circuitry to stop the motor whether in DRIVE or BYPASS mode in case of an external safety fault.
- B. The bypass shall be made such that the Run Enable Function will operate in bypass mode.

2.09 SERVICE CONDITIONS

- A. Continuous operation at ambient temperature, -10 to +40°C (14 to 104°F), without derating.
- B. 0 to 95% relative humidity, non-condensing.
- C. Elevation to 3,300 feet without derating.
- D. AC line voltage variation, -10 to +10% of nominal voltage, while rated motor torque is maintained.
- E. No side clearance shall be required for cooling of wall mount units and all power and control wiring shall be done from the bottom.
- F. The frequency converter shall be capable of operating a motor up to 150m away without derating or field modification.

■ Part 3 Execution

3.01 Start-up Service

- A. The manufacturer shall provide start-up commissioning of the frequency converter and its optional circuits by a factory certified service technician who is experienced in start-up and repair services. The commissioning personnel shall be the same personnel that will provide the factory service and warranty repairs at the customer's site. Sales personnel and other agents who are not factory certified technicians for frequency converter field repair shall not be acceptable as commissioning agents. Start-up services shall include checking for verification of proper operation and installation for the frequency converter, its options and its interface wiring to the building automation system. Start-up shall include customer operator training at the time of the equipment commissioning.

3.02 Warranty

- A. The frequency converter shall be warranted by the manufacturer for a period of 18 months from date of shipment. The warranty shall include parts, labour, travel costs and living expenses incurred by the manufacturer to provide factory authorized on-site service.

3.03 Examination

- A. Contractor to verify that job site conditions for installation meet factory recommended and code-required conditions for frequency converter installation prior to start-up, including clearance spacing, temperature, contamination, dust, and moisture of the environment. Separate installation of the motor wiring, power wiring, and control wiring, and installation per the manufacturer's recommendations shall be verified.
- B. The frequency converter is to be covered and protected from installation dust and contamination until the environment is cleaned and ready for operation. The frequency converter shall not be operated while the unit is covered.

■ Ordering guide

This section makes it easier for you to specify and order a VLT 6000 HVAC.

■ Choice of frequency converter

The frequency converter should be chosen on the basis of the given motor current at maximum load on the system. The rated output current $I_{VLT,N}$ must be equal to or higher than the required motor current.

VLT 6000 HVAC is available for two mains voltage ranges: 200-240 V and 380-460 V.

■ Mains voltage

Choose mains voltage for 50/60 Hz:

- 200-240 V three-phase AC voltage
- 380-460 V three-phase AC voltage

Mains voltage 200 - 240 V

VLT type	Typical shaft output		Max continuous output current $I_{VLT,N}$ [A]	Max continuous output power at 240 V $S_{VLT,N}$ [kVA]
	$P_{VLT,N}$ [kW]	[HP]		
6002	1.1	1.5	6.6	2.7
6003	1.5	2.0	7.5	3.1
6004	2.2	3.0	10.6	4.4
6005	3.0	4.0	12.5	5.2
6006	4.0	5.0	16.7	6.9
6008	5.5	7.5	24.2	10.1
6011	7.5	10	30.8	12.8
6016	11	15	46.0	19.1
6022	15	20	59.4	24.7
6027	18.5	25	74.8	31.1
6032	22	30	88.0	36.6
6042	30	40	115/104*	43.2
6052	37	50	143/130*	54.0
6062	45	60	170/154*	64.0

* The first figure is for a motor voltage of 200-230 V.
The next figure is for a motor voltage of 231-240 V.

VLT® 6000 HVAC

Mains voltage 380 - 415 V

VLT type	Typical shaft output $P_{VLT.N}$		Max continuous output current $I_{VLT.N}$ [A]	Max continuous output power at 400 V $S_{VLT.N}$ [kVA]
	[kW]	[HP]		
6002	1.1	1.5	3.0	2.2
6003	1.5	2.0	4.1	2.9
6004	2.2	3.0	5.6	4.0
6005	3.0	-	7.2	5.2
6006	4.0	5.0	10.0	7.2
6008	5.5	7.5	13.0	9.3
6011	7.5	10	16.0	11.5
6016	11	15	24.0	17.3
6022	15	20	32.0	23.0
6027	18.5	25	37.5	27.0
6032	22	30	44.0	31.6
6042	30	40	61.0	43.8
6052	37	50	73.0	52.5
6062	45	60	90.0	64.7
6075	55	75	106	73.0
6100	75	100	147	102
6125	90	125	177	123
6150	110	150	212	147
6175	132	200	260	180
6225	160	250	315	218
6275	200	300	368	255

Mains voltage 440 - 460 V

VLT type	Typical shaft output $P_{VLT.N}$		Max continuous output current $I_{VLT.N}$ [A]	Max continuous output power at 460 V $S_{VLT.N}$ [kVA]
	[kW]	[HP]		
6002	1.1	1.5	3.0	2.4
6003	1.5	2.0	3.4	2.7
6004	2.2	3.0	4.8	3.8
6005	3.0	-	6.3	5.0
6006	4.0	5.0	8.2	6.5
6008	5.5	7.5	11.0	8.8
6011	7.5	10	14.0	11.2
6016	11	15	21.0	16.7
6022	15	20	27.0	21.5
6027	18.5	25	34.0	27.1
6032	22	30	40.0	31.9
6042	30	40	52.0	41.4
6052	37	50	65.0	51.8
6062	45	60	77.0	61.3
6075	55	75	106	84.5
6100	75	100	130	104
6125	90	125	160	127
6150	110	150	190	151
6175	132	200	240	191
6225	160	250	302	241
6275	200	300	361	288

■ Enclosure

VLT 6000 HVAC is available with the following enclosures:

- IP 00: 30 to 45 kW / 200-240 V
- IP 00: 55 to 200 kW / 380-460 V
- Bookstyle IP 20: 1.1 to 3.0 kW / 200-240 V
- Bookstyle IP 20: 1.1 to 7.5 kW / 380-460 V
- IP 20: 1.1 to 45 kW / 200-240 V
- IP 20: 1.1 to 200 kW / 380-460 V
- IP 54: 1.1 to 45 kW / 200-240 V
- IP 54: 1.1 to 200 kW / 380-460 V

IP 00: This enclosure is only available for the larger power sizes of the VLT 6000 HVAC series. It is recommended for installation in standard cabinets.

IP 20 Bookstyle: This enclosure is designed for cabinet installation. It takes up a minimum of space and can be fitted side-by-side without installation of extra cooling equipment.

IP 20: This enclosure is used as standard enclosure for VLT 6000 HVAC. It is ideal for cabinet installation in areas where a high degree of protection is required. This enclosure also permits side-by-side installation.

IP 54: This enclosure can be fitted direct to the wall. Cabinets are not required. IP 54 units can also be installed side-by-side.

■ RFI filter

As standard, the VLT 6000 HVAC has an integral RFI filter up to and including 7.5 kW (3 kW 200 V).

These RFI filters comply with EMC standards EN 55011-1A, provided max. 150 m screened/armoured cable is used, and with EN 55011-1B, provided 50 m screened/armoured cable is used (Bookstyle max. 20 m screened/armoured).

Select a RFI filter for dampening of interference in accordance with EN 55011-1A and EN 55011-1B.

■ Harmonic filter

The harmonic currents do not directly affect the electricity consumption, but they do increase the heat losses in the installation (transformers, cables). That is why in systems with a rather high percentage of rectifier load it is important to keep the harmonic currents at a low level in order to avoid transformer overloads and high cable temperatures.

As standard, the VLT 6000 HVAC has coils in the intermediate circuit in order to ensure low harmonic currents. This typically reduces the input current I_{RMS} by 40 %.

■ Control unit (LCP)

The VLT 6000 HVAC is available with or without control unit (LCP); however, IP 54 units always come with the control unit.

This control unit makes up a complete interface for control and programming of the VLT 6000 HVAC. The control panel is detachable and may - as an alternative - be mounted up to 3 metres away from the VLT frequency converter, i.e. in a cabinet, by means of a fitting kit delivered with the unit.

Data information is given in a 4-line alpha-numerical display, which under normal operation is able to continuously show four operating data items and three operating modes. During programming, all the information required for quickly and efficiently setting up VLT frequency converter parameters will be shown.

As a supplement to the display, there are three indicator lamps for voltage (ON), warning (WARNING) and alarm (ALARM).

All VLT frequency converter parameter Setups can be changed directly via the control panel.

The following options are available:

- Control panel LCP (only for IP 20 units).
- LCP remote-mounting kit for remote control of IP 00 and IP 20 units.
- LCP remote-mounting kit for remote control of IP 54.
- 3 metre cable for LCP.

■ **Fieldbus protocols**

Danfoss VLT frequency converters are able to fulfil many different functions in an automated building management system. The VLT frequency converter can be integrated directly in an overall monitoring system.

This means that detailed process data can be transmitted via serial communication. The protocols listed below are based on a RS 485 bus system with a maximum transmission speed of 9600 bauds.

As standard, the following protocols are supported:

- Danfoss FC protocol
- Johnson's Control Metasys N2
- Landis/Staefa FLN ¹⁾

¹⁾ Available from approx. October 1998.

A frequency converter can be set and applied in all building management control systems.

Status messages, warnings and alarms provide valuable assistance in visualising and assessing processes.

■ **Fieldbus options**

The increasing need for information in building management systems makes it necessary to collect or visualise many different types of process data. Important process data can help the system technician in the day-by-day monitoring of the system, which means that a negative development - e.g. an increase in energy consumption - can be rectified in time.

The substantial amount of data in large buildings may generate a need for a higher transmission speed than 9600 bauds. Danfoss VLT 6000 HVAC is available with LonWorks® or Profibus®, both of which have higher performance than standard integrated serial communication.

■ **Profibus**

Profibus is a fieldbus system with FMS and DP, which can be used for linking automation units, such as sensors and actuators, to the controls by means of a two-conductor cable.

Profibus **FMS** is used if major communication tasks are to be solved at cell and system level by means of large volumes of data.

Profibus **DP** is an extremely fast communication protocol, made specially for communication between the automation system and various units.

■ **LON - Local Operating Network**

LonWorks is an intelligent fieldbus system which improves the possibility of decentralising control, as communication is enabled between individual units in the same system (Peer-to-Peer).

This means that there is no need for a big main station for handling all the signals of the system (Master-Slave). Signals are sent direct to the unit that needs them via a common network medium. This makes communication much more flexible and the central building state control and monitoring system can be changed into a dedicated building state monitoring system whose task is to ensure that everything is running as planned. If the potential of LonWorks is fully utilised, sensors will also be connected to the bus, which means that a sensor signal can quickly be moved to another controller. If room dividers are mobile, this is a particularly useful feature.

Two feedback signals can be linked to the VLT 6000 HVAC by means of LonWorks, thereby enabling the internal PID regulator to regulate directly on the bus feedback.

■ **Unpacking and ordering a VLT frequency converter**

Are you are in doubt as to which VLT frequency converter you have received and which options it contains? Use the following table to find out. The table can also be used for ordering a VLT 6000 HVAC.

■ **Type code ordering number string**

On the basis of your order, the VLT frequency converter is given an ordering number that can be seen from the nameplate on the unit. The number may look as follows:

VLT-6008-H-T5-B20-R3-DL-F10-A10

This means that the frequency converter ordered is a VLT 6008 for three-phase mains voltage of 380-460 V (**T4**) in Bookstyle enclosure IP 20 (**B20**). The hardware variant is with integral RFI filter, classes A & B (**R3**). The frequency converter features a control unit (**DL**) with a PROFIBUS option card (**F10**). Character no. 8 (**H**) indicates the application range of the unit: **H** = HVAC.

Bookstyle IP 20

Motor power	Mains voltage, rated:	
	200-240 V	380-460 V
1.1 kW	VLT 6002	VLT 6002
1.5 kW	VLT 6003	VLT 6003
2.2 kW	VLT 6004	VLT 6004
3.0 kW	VLT 6005	VLT 6005
4.0 kW		VLT 6006
5.5 kW		VLT 6008
7.5 kW		VLT 6011

Motor power	Mains voltage, rated:	
	200-240 V	380-460 V
1.1 kW	VLT 6002	VLT 6002
1.5 kW	VLT 6003	VLT 6003
2.2 kW	VLT 6004	VLT 6004
3.0 kW	VLT 6005	VLT 6005
4.0 kW	VLT 6006	VLT 6006
5.5 kW	VLT 6008	VLT 6008
7.5 kW	VLT 6011	VLT 6011
11 kW	VLT 6016	VLT 6016
15 kW	VLT 6022	VLT 6022
18.5 kW	VLT 6027	VLT 6027
22 kW	VLT 6032	VLT 6032
30 kW	VLT 6042	VLT 6042
37 kW	VLT 6052	VLT 6052
45 kW	VLT 6062	VLT 6062

Units in the range of 1.1-45 kW come with enclosure IP 20, IP 54.

Mains voltage, rated:

Motor power	400 V ¹⁾	460 V ¹⁾
55 kW	VLT 6075	-
75 kW	VLT 6100	VLT 6075
90 kW	VLT 6125	VLT 6100
110 kW	VLT 6150	VLT 6125
132 kW	VLT 6175	VLT 6150
160 kW	VLT 6225	VLT 6175
200 kW	VLT 6275	VLT 6225
250 kW		VLT 6275

Units in the range of 55-250 kW come with enclosure IP 00, IP 20 or IP 54.

¹⁾ The max. output depends on the mains voltage connected to the unit.

Hardware variants

All units in the programme are available in the following hardware variants:

ST: Standard unit w/ or w/o control unit.

RFI-filter

Bookstyle units always come *with* an integral RFI filter that complies with EN 55011-1B with 20 m screened /armoured motor cable and EN 55011-1A with 150 m screened/armoured motor cable.

Units for a mains voltage of 240 V and a motor power of up to and including 4.0 kW (VLT 6006) and units for a mains voltage of 380-460 V and a motor power of up to 7.5 kW (VLT 6011) are always supplied with an integral class 1A & 1B filter.

Units for higher motor power than these (4.0 and 7.5 kW, respectively) can be ordered either with or without an RFI filter.

Control unit (keypad and display)

All types of units in the programme, except for IP 54 units, can be ordered either with or without the control unit. IP 54 units always come *with* a control unit.

Ordering form VLT 6000 HVAC

Introduction to HVAC

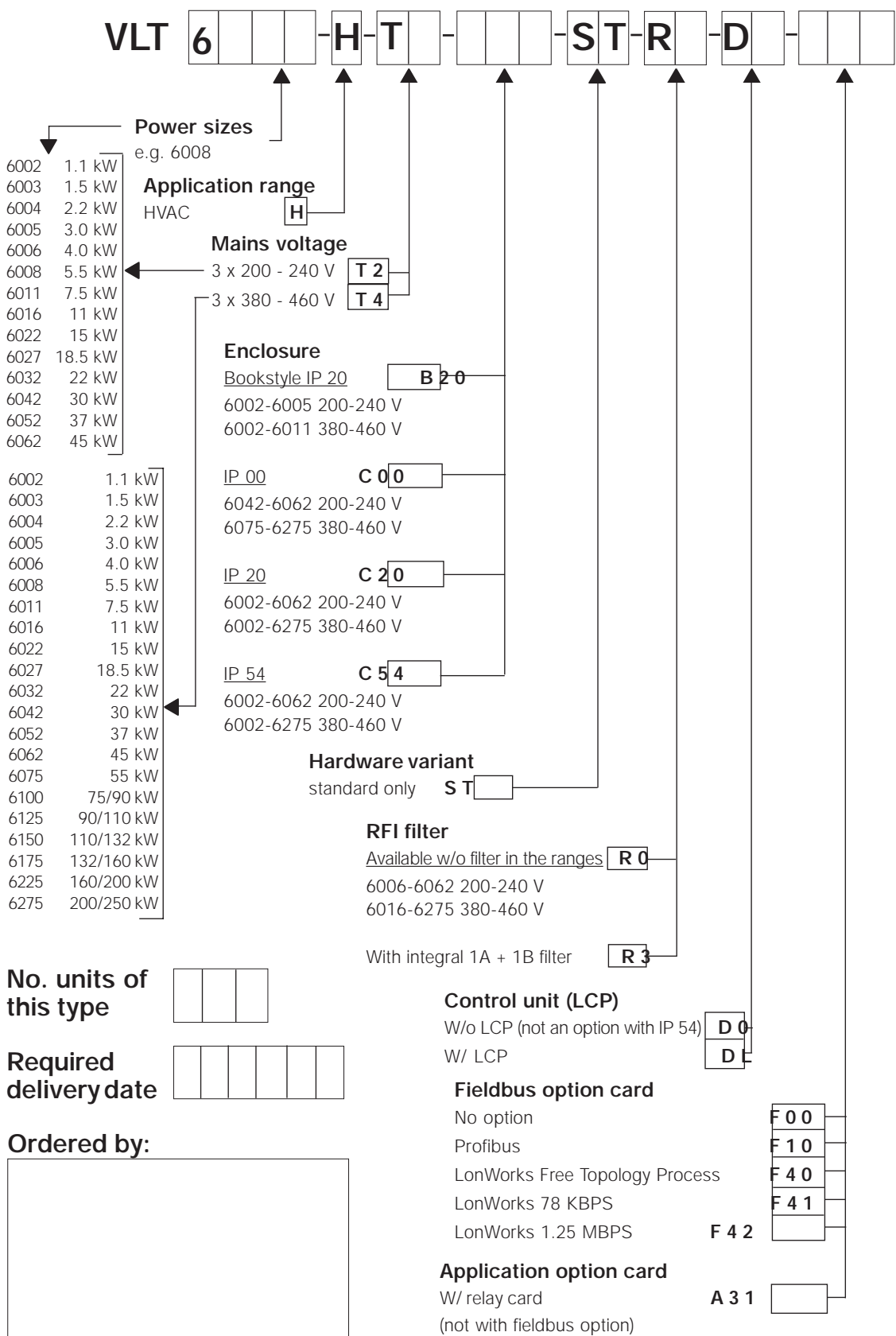

Date: _____

Take a copy of the ordering forms. Fill them in and send or fax your order to the nearest office of the Danfoss sales organisation.

■ Accessories for VLT 6000 HVAC

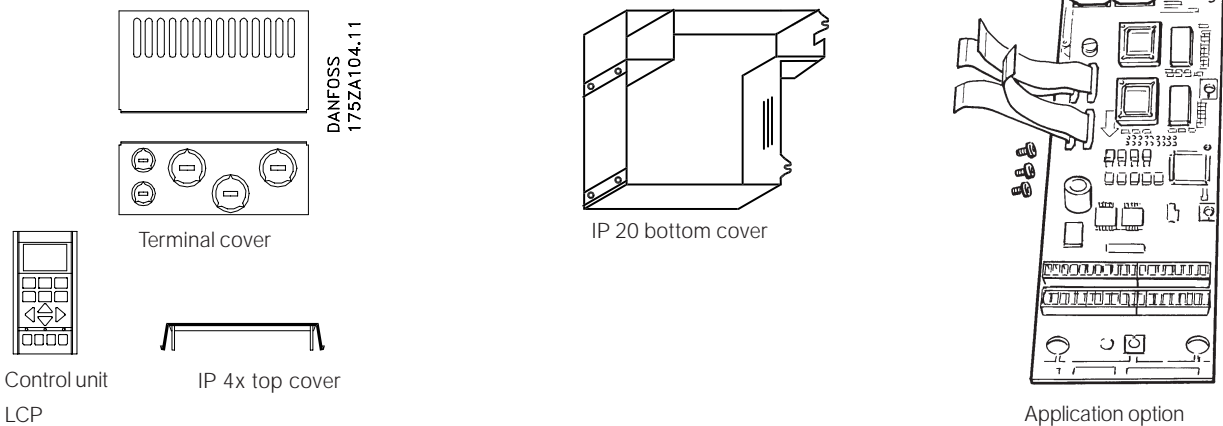

■ Ordering numbers, misc.

Type	Description	Order no.
IP 4x top cover ¹⁾	Option, VLT type 6002-6005 200-240 V	175Z0928
IP 4x top cover ¹⁾	Option, VLT type 6002-6011 380-460 V	175Z0928
NEMA 12 bonding plate ²⁾	Option, VLT type 6002-6005 200-240 V	175H4195
NEMA 12 bonding plate ²⁾	Option, VLT type 6002-6011 380-460 V	175H4195
IP 20 terminal cover	Option, VLT type 6006-6016 200-240 V	175Z4622
IP 20 terminal cover	Option, VLT type 6022-6027 200-240 V	175Z4623
IP 20 terminal cover	Option, VLT type 6016-6032 380-460 V	175Z4622
IP 20 terminal cover	Option, VLT type 6042-6062 380-460 V	175Z4623
IP 20 bottom cover	Option, VLT type 6042-6062 200-240 V	176F1800
IP 20 bottom cover	Option, VLT type 6060-6100 380-460 V	176F1800
IP 20 bottom cover	Option, VLT type 6125-6250 380-460 V	176F1801
Control panel LCP	Separate LCP	175Z7804
LCP remote-mounting kit IP 00 & 20 ³⁾	Remote-mounting kit for LCP, for IP 00 and IP 20 units	175Z0850 incl. 3 m cable
LCP remote-mounting kit IP 54 ⁴⁾	Remote-mounting kit for LCP, for IP 54 units	175Z7802 incl. 3 m cable
Cable for LCP	Separate cable	175Z0929 3 m cable
VLT® Software, Dialog	Basic module Danish manual	175Z0900
VLT® Software, Dialog	Basic module English manual	175Z0903
VLT® Software, Dialog	Basic module German manual	175Z0904
VLT® Software, Dialog	Basic module Italian manual	175Z0905
VLT® Software, Dialog	Basic module Spanish manual	175Z0906
VLT® Software, Dialog	Basic module French manual	175Z0907
VLT® Software, Dialog	Logging module	175Z0909
VLT® Software, Dialog	Template module	175Z0908
VLT® Software, Dialog	Guided tour	175Z0952
Relay card	Application card with four relay outputs	175Z7803 3 m cable
Profibus option		175Z7800
LonWorks option, Free topology		176F1515
LonWorks option, 78 KBPS		176F1516
LonWorks option, 1.25 MBPS		176F1517

- 1) IP 4x/NEMA 1 top cover is for IP 20 units only and only horizontal surfaces comply with IP 4x. The kit also contains a bonding plate (UL).
- 2) NEMA 12 bonding plate (UL) is only for IP 54 units.
- 3) The remote-mounting kit is only for IP 00 and IP 20 units. Enclosure of the remotemounting kit is IP 65.
- 4) The remote-mounting kit is only for IP 54 units. Enclosure of the remote-mounting kit is IP 65.

VLT 6000 HVAC is available with an integral fieldbus option or application option. Ordering numbers for the individual VLT types with integrated options can be seen from the relevant manuals or instructions. In addition, the ordering number system can be used for ordering a VLT frequency converter with an option.

■ LC filters for VLT 6000 HVAC

When a motor is controlled by a frequency converter, resonance noise will be heard from the motor. This noise, which is caused by the design of the motor, occurs each time one of the inverter switches in the frequency converter is activated. Consequently, the resonance noise frequency corresponds to the switching frequency of the frequency converter.

For the VLT 6000 HVAC, Danfoss offers a LC filter to dampen the acoustic motor noise.

This filter reduces the voltage rise time, the peak voltage U_{PEAK} and the ripple current ΔI to the motor, thereby making current and voltage almost sinusoidal. The acoustic motor noise is therefore reduced to a minimum.

Because of the ripple current in the coils, there will be some noise from the coils. This problem can be solved entirely by integrating the filter in a cabinet or similar.

■ Examples of the use of LC filtersSubmersible pumps

For small motors with up to and including 5.5 kW rated motor power, use a LC filter, unless the motor is equipped with phase separation paper. This applies e.g. to all wet running motors. If these motors are used without LC filter in connection with a frequency converter, the motor windings will short-circuit. If in doubt, ask the motor manufacturer whether the motor in question is equipped with phase separation paper.

Well pumps

If immersion pumps are used, e.g. submerged pumps or well pumps, the supplier should be contacted for clarification of requirements. It is recommended to use a LC filter if a VLT frequency converter is used for immersion operations.

Long motor cables

If screened/armoured motor cables longer than 150 m or unscreened/unarmoured motor cables longer than 300 m are used, a LC filter should be applied. The LC filter reduces the capacitive earth leakage currents and the voltage peak loads.

**NB!:**

If a VLT frequency converter controls several motors in parallel, the motor cables must be added up to give the total cable length.

■ Ordering numbers, LC filter modules
Mains supply 3 x 200 - 240 V

LC filter for VLT type	LC filter enclosure	Rated current at 200 V	Max. output frequency	Power loss	Order no.
6002-6003 Bookstyle	IP 20 Bookstyle	7.8 A	120 Hz		175Z0825
6004-6005 Bookstyle	IP 20 Bookstyle	15.2 A	120 Hz		175Z0826
6002-6005	IP 20	15.2 A	120 Hz		175Z0832
6006-6008	IP 00	25.0 A	60 Hz	85 W	175Z4600
6011	IP 00	32 A	60 Hz	90 W	175Z4601
6016	IP 00	46 A	60 Hz	110 W	175Z4602
6022	IP 00	61 A	60 Hz	170 W	175Z4603
6027	IP 00	73 A	60 Hz	250 W	175Z4604
6032	IP 00	88 A	60 Hz	320 W	175Z4605

Mains supply 3 x 380 - 460 V

LC filter for VLT type	LC filter enclosure	Rated current at 400/460 V	Max. output frequency	Power loss	Order no.
6002-6005 Bookstyle	IP 20 Bookstyle	7.2 A / 6.3 A	120 Hz		175Z0825
6006-6011 Bookstyle	IP 20 Bookstyle	16 A / 16 A	120 Hz		175Z0826
6002-6011	IP 20	16 A / 16 A	120 Hz		175Z0832
6016	IP 00	24 A / 21.7 A	60 Hz	125 W	175Z4606
6022	IP 00	32 A / 27.9 A	60 Hz	130 W	175Z4607
6027	IP 00	37.5 A / 32 A	60 Hz	140 W	175Z4608
6032	IP 00	44 A / 41.4 A	60 Hz	170 W	175Z4609
6042	IP 00	61 A / 54 A	60 Hz	250 W	175Z4610
6052	IP 00	73 A / 65 A	60 Hz	360 W	175Z4611
6062	IP 00	90 A / 78 A	60 Hz	450 W	175Z4612
6075	IP 20	106 A / 106 A	60 Hz		175Z4701
6100	IP 20	147 A / 130 A	60 Hz		175Z4702
6125	IP 20	177 A / 160 A	60 Hz		175Z4703
6150	IP 20	212 A / 190 A	60 Hz		175Z4704
6175	IP 20	260 A / 240 A	60 Hz		175Z4705
6225	IP 20	315 A / 302 A	60 Hz		175Z4706
6275	IP 20	395 A / 361 A	60 Hz		175Z4707

■ LC filters 6002-6006, 200 - 240 V / 6002-6011 380 - 460 V

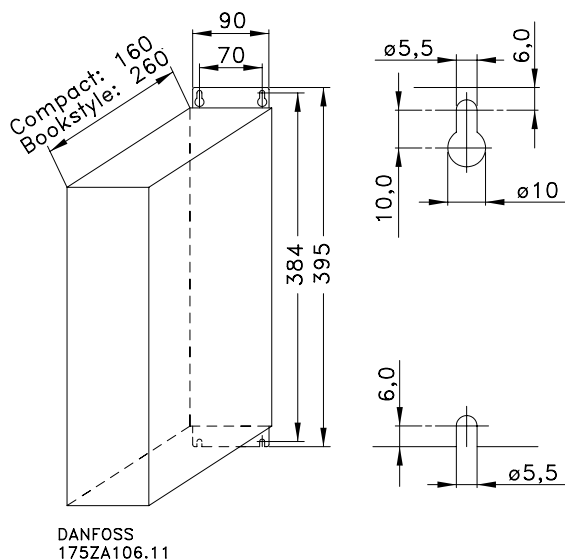

The drawing on the left gives the measurements of IP 20 LC filters for the above-mentioned power range. Min. space above and under enclosure: 100 mm.

IP 20 LC filters have been designed for side-by-side installation without any space between enclosures.

Max. motor cable length:

- 150 m screened/armoured cable
- 300 m unscreened/unarmoured cable

If EMC standards are to be complied with:

- EN 55011-1B: Max. 50 screened/armoured cable
Bookstyle: Max. 20 m screened/armoured cable
- EN 55011-1A: Max. 150 m screened/armoured cable

Weight:	175Z0825	7.5 kg
	175Z0826	9.5 kg
	175Z0832	9.5 kg

■ Installation of LC filter IP 20 Bookstyle

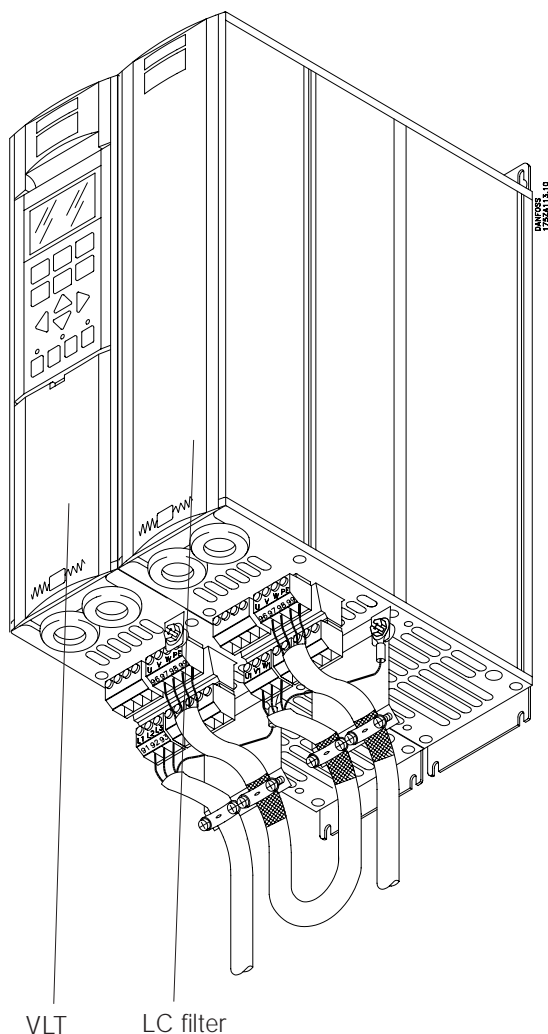

■ Installation of LC filter IP 20

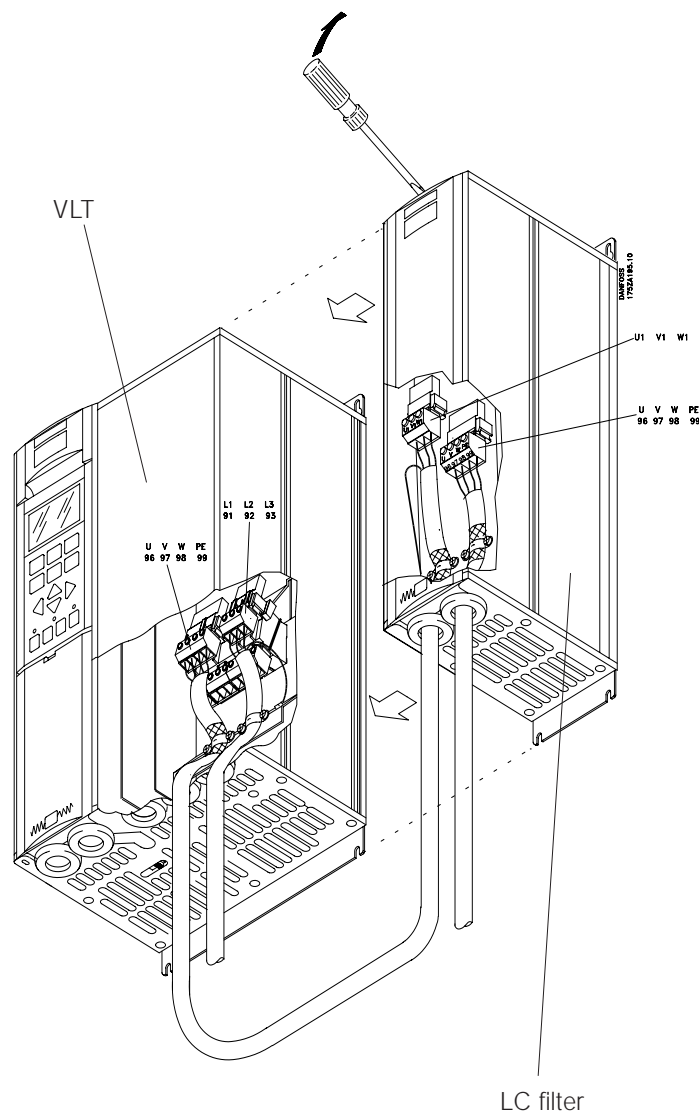

■ LC filters VLT 6008-6032, 200 - 240 V / 6016-6062 380 - 460 V

The table and the drawing give the measurements of IP 00 LC filters for Compact units.

IP 00 LC filters must be integrated and protected against dust, water and corrosive gases.

Max. motor cable length:

- 150 m screened/armoured cable
- 300 m unscreened/unarmoured cable

If EMC standards are to be complied with:

- EN 55011-1B: Max. 50 screened/armoured cable
Bookstyle: Max. 20 m screened/armoured cable
- EN 55011-1A: Max. 150 m screened/armoured cable

LC filter IP 00

LC type	A [mm]	B [mm]	C [mm]	D [mm]	E [mm]	F [mm]	G [mm]	Weight [kg]
175Z4600	220	135	92	190	68	170	8	10
175Z4601	220	145	102	190	78	170	8	13
175Z4602	250	165	117	210	92	180	8	17
175Z4603	295	200	151	240	126	190	11	29
175Z4604	355	205	152	300	121	240	11	38
175Z4605	360	215	165	300	134	240	11	49
175Z4606	280	170	121	240	96	190	11	18
175Z4607	280	175	125	240	100	190	11	20
175Z4608	280	180	131	240	106	190	11	23
175Z4609	295	200	151	240	126	190	11	29
175Z4610	355	205	152	300	121	240	11	38
175Z4611	355	235	177	300	146	240	11	50
175Z4612	405	230	163	360	126	310	11	65

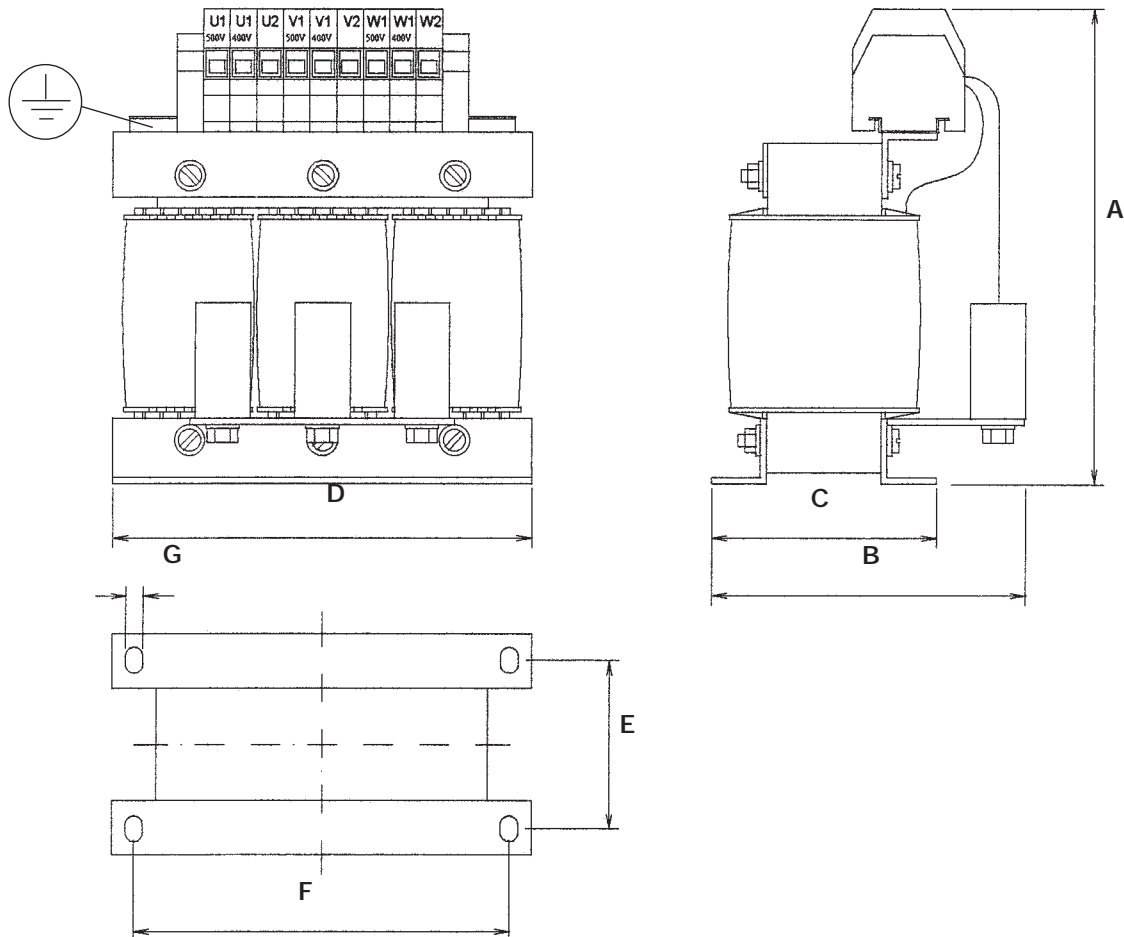

■ **LC filter 6075-6275 380 - 460 V**

The table and the drawing give the measurements of IP 20 LC filters. IP 20 LC filters must be integrated and protected against dust, water and aggressive gases.

Max. motor cable length:

- 150 m screened/armoured cable
- 300 m unscreened/unarmoured cable

If EMC standards are to be complied with:

- EN 55011-1B: Max. 50 m screened/armoured cable
Bookstyle: Max. 20 m screened/armoured cable
- EN 55011-1A: Max. 150 m screened/armoured cable

LC-filter IP 20								
LC type	A [mm]	B [mm]	C [mm]	D [mm]	E [mm]	F [mm]	G [mm]	Weight [kg]
175Z4701	740	550	600					70
175Z4702	740	550	600					70
175Z4703	740	550	600					110
175Z4704	740	550	600					120
175Z4705	830	630	650					220
175Z4706	830	630	650					250
175Z4707	830	630	650					250

DANFOSS
175HA428.10

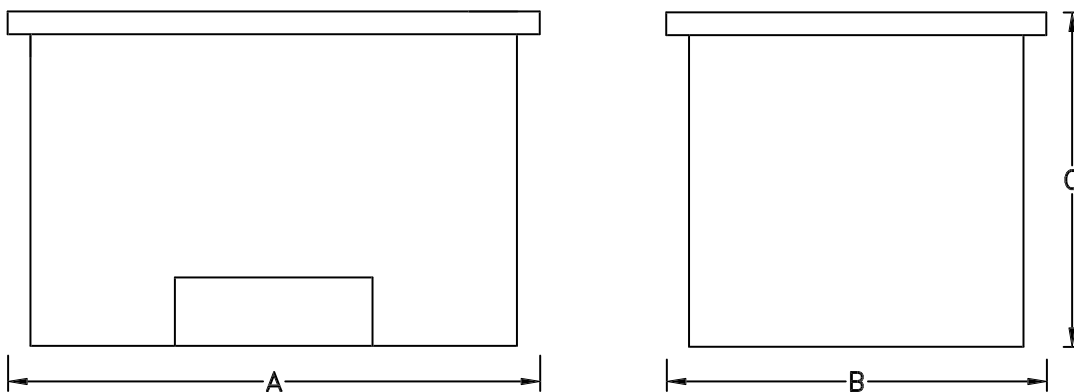

■ General technical data
Mains supply (L1, L2, L3):

Supply voltage 200-240 V units	3 x 200/208/220/230/240 V ±10%
Supply voltage 380-460 V units	3 x 380/400/415/440/460 V ±10%
Supply frequency	50/60 Hz
Max. imbalance of supply voltage	±2% of rated supply voltage
Power factor / cos. ϕ	0.90/1.0 at rated load
No. of switches on supply input L1, L2, L3	approx. 1 time/min.
Max. short-circuit current	100.000 A

VLT output data (U, V, W):

Output voltage	0-100% of supply voltage
Output frequency	0 - 120 Hz, 0 - 1000 Hz
Rated motor voltage, 200-240 V units	200/208/220/230/240 V
Rated motor voltage, 380-460 V units	380/400/415/440/460/500 V
Rated motor frequency	50/60 Hz
Switching on output	Unlimited
Ramp times	1- 3600 sec.

Torque characteristics:

Starting torque	110% for 1 min.
Starting torque (parameter 110 <i>High break-away torque</i>)	Max. torque: 160% for 0.5 sec.
Acceleration torque	100%
Overload torque	110%

Control card, digital inputs:

Number of programmable digital inputs	8
Terminal nos.	16, 17, 18, 19, 27, 29, 32, 33
Voltage level	0-24 V DC (PNP positive logics)
Voltage level, logical '0'	< 5 V DC
Voltage level, logical '1'	> 10 V DC
Maximum voltage on input	28 V DC
Input resistance, R_i	approx. 2 k Ω
Scanning time per input	3 msec.

Reliable galvanic isolation: All digital inputs are galvanically isolated from the supply voltage (PELV). In addition, the digital inputs can be isolated from the other terminals on the control card by connecting an external 24 V DC supply and opening switch 4. See drawing on page 65.

Control card, analogue inputs:

No. of programmable analogue voltage inputs	2
Terminal nos.	53, 54
Voltage level	0 - 10 V DC (scalable)
Input resistance, R_i	approx. 10 k Ω
No. of programmable analogue current inputs	1
Terminal no.	60
Current range	0/4 - 20 mA (scalable)
Input resistance, R_i	approx. 200 Ω
Resolution	10 bit + sign
Accuracy on input	Max. error 1% of full scale
Scanning time per input	3 msec.

Reliable galvanic isolation: All analogue inputs are galvanically isolated from the supply voltage (PELV) and other high-voltage terminals.

■ General technical data
Control card, pulse input:

No. of programmable pulse inputs	3
Terminal nos.	17, 29, 33
Max. frequency on terminal 17	5 kHz
Max. frequency on terminals 29, 33	20 kHz (PNP open collector)
Max. frequency on terminals 29, 33	65 kHz (Push-pull)
Voltage level	0-24 V DC (PNP positive logics)
Voltage level, logic '0'	< 5 V DC
Voltage level, logic '1'	> 10 V DC
Maximum voltage on input	28 V DC
Input resistance, R_i	approx. 2 k Ω
Scanning time per input	3 msec.
Resolution	10 bit + sign
Accuracy (100-1 kHz), terminals 17, 29, 33	Max. error: 0.5% of full scale
Accuracy (1-5 kHz), terminal 17	Max. error: 0.1% of full scale
Accuracy (1-65 kHz), terminals 29, 33	Max. error: 0.1% of full scale

Reliable galvanic isolation: All pulse inputs are galvanically isolated from the supply voltage (PELV). In addition, pulse inputs can be isolated from the other terminals on the control card by connecting an external 24 V DC supply and opening switch 4. See drawing on page 65.

Control card, digital/pulse and analogue outputs:

No. of programmable digital and analogue outputs	2
Terminal nos.	42, 45
Voltage level at digital/pulse output	0 - 24 V DC
Minimum load to frame (terminal 39) at digital/pulse output	600 Ω
Frequency ranges (digital output used as pulse output)	0-32 kHz
Current range at analogue output	0/4 - 20 mA
Maximum load to frame (terminal 39) at analogue output	500 Ω
Accuracy of analogue output	Max. error: 1.5% of full scale
Resolution on analogue output	8 bit

Reliable galvanic isolation: All digital and analogue outputs are galvanically isolated from the supply voltage (PELV) and other high-voltage terminals.

Control card, 24 V DC supply:

Terminal nos.	12, 13
Max. load	200 mA

Reliable galvanic isolation: The 24 V DC supply is galvanically isolated from the supply voltage (PELV), but has the same potential as the analogue outputs.

Control card, RS 485 serial communication:

Terminal nos.	68 (TX+, RX+), 69 (TX-, RX-)
--------------------	------------------------------

Reliable galvanic isolation: Full galvanic isolation (PELV).

Relay outputs:

No. of programmable relay outputs	2
Terminal nos., control card	4-5 (make)
Max. terminal load (AC) on 4-5, control card	50 V AC, 1 A, 60 VA
Max. terminal load (DC) on 4-5, control card	75 V DC, 1 A, 30 W
Max. terminal load (AC) on 4-5, control card for UL/cUL applications	30 V AC, 1 A
Max. terminal load (DC) on 4-5, control card for UL/cUL applications	42.2 V DC, 1 A
Terminal nos., power card and relay card	1-3 (break), 1-2 (make)
Max. terminal load (AC) on 1-3, 1-2, power card and relay card	240 V AC, 2 A, 60 VA
Min. terminal load on 1-3, 1-2, power card and relay card	24 V DC 10 mA, 24 V AC 100 mA

■ General technical data
Cable lengths and cross-sections:

Max. motor cable length, screened/armoured cable	150 m
Max. motor cable length, unscreened/unarmoured cable	300 m
Max. motor cable length, screened/armoured cable VLT 6011 380-460 V	100 m
Max. DC-bus cable length, screened/armoured cable	25 m from frequency converter to DC bar.
<i>Max. cable cross-section to motor, see next section</i>	
Max. cross-section for control cables	1.5 mm ² /16 AWG
Max. cross-section for serial communication	1.5 mm ² /16 AWG

Control characteristics:

Frequency range	0 - 1000 Hz
Resolution on output frequency	±0.003 Hz
System response time	3 msec.
Speed, control range (open loop)	1:100 of synchro. speed
Speed, control range (closed loop)	1:1000 of synchro. speed
Speed, accuracy (open loop)	< 1500 rpm: max. error ± 7.5 rpm > 1500 rpm: max. error of 0.5% of actual speed
Speed, accuracy (closed loop)	< 1500 rpm: max. error ± 1.5 rpm > 1500 rpm: max. error of 0.1% of actual speed

All control characteristics are based on a 4-pole asynchronous motor

Accuracy of Display readout (parameters 009-012 Display readout):

Motor current [5], 0 - 140% load	Max. error: ±2.0% of rated output current
Power kW [6], Power HP [7], 0 - 90% load	Max. error: ±5.0% of rated output power

Externals:

Enclosure	IP 00, IP 20, IP 54
Vibration test	0.7 g
Max. relative humidity	93 % +2 %, -3 % (IEC 68-2-3) for storage/transport
Ambient temperature IP 00/20/54	Max. 45°C (24-hour average max. 40°C)
Ambient temperature IP 20/54 VLT 6011 460 V	Max. 40°C (24-hour average max. 35°C)
<i>Derating for high ambient temperature, see page 160</i>	
Min. ambient temperature in full operation	0°C
Min. ambient temperature at reduced performance	-10°C
Temperature during storage/transport	-25 - +65/70°C
Max. altitude above sea level	1000 m

Derating for high air pressure, see page 160

EMC standards applied, Emission	EN 50081-1/2, EN 61800-3, EN 55011, EN 55014
Immunity	EN 50082-2, EN 61000-4-2, IEC 1000-4-3, EN 61000-4-4 EN 61000-4-5, ENV 50204, EN 61000-4-6, VDE 0160/1990.12

VLT 6000 HVAC protection:

- Electronic motor thermal protection against overload.
- Temperature monitoring of heat-sink ensures that the VLT frequency converter cuts out if the temperature reaches 90°C for IP 00 and IP 20. For IP 54, the cut-out temperature is 80°C. An overtemperature can only be reset when the temperature of the heat-sink has fallen below 60°C.
- The VLT frequency converter is protected against short-circuiting on motor terminals U, V, W.
- The VLT frequency converter is protected against earth fault on motor terminals U, V, W.
- Monitoring of the intermediate circuit voltage ensures that the VLT frequency converter cuts out if the intermediate circuit voltage gets too high or too low.
- If a motor phase is missing, the VLT frequency converter cuts out.
- If there is a mains fault, the VLT frequency converter is able to carry out a controlled deramping.
- If a mains phase is missing, the VLT frequency converter will cut out when a load is placed on the motor.

■ Mains supply 3 x 200 - 240 V

According to international requirements

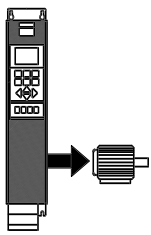

	VLT type	6002	6003	6004	6005	6006	6008	6011
Output current ⁴⁾	$I_{VLT,N}$ [A]	6.6	7.5	10.6	12.5	16.7	24.2	30.8
	$I_{VLT,MAX}$ (60 s) [A]	7.3	8.3	11.7	13.8	18.4	26.6	33.9
Output (240 V)	$S_{VLT,N}$ [kVA]	2.7	3.1	4.4	5.2	6.9	10.1	12.8
Typical shaft output	$P_{VLT,N}$ [kW]	1.1	1.5	2.2	3.0	4.0	5.5	7.5
Typical shaft output	$P_{VLT,N}$ [HP]	1.5	2	3	4	5	7.5	10
Max. cable cross-section to motor and DC-bus	[mm ² /AWG]	4/10	4/10	4/10	4/10	4/10	16/6	16/6

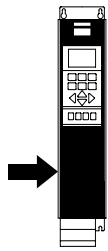

Max. input current (200 V)	$I_{L,N}$ [A]	6.0	7.0	10.0	12.0	16.0	23.0	30.0
Max. cable cross-section power [mm ²]/[AWG] ²⁾		4/10	4/10	4/10	4/10	4/10	16/6	16/6
	Max. pre-fuses	[A]/UL ¹⁾ [A]	16/10	16/15	25/20	25/25	35/30	50
Mains contactor	[Danfoss type]	CI 6	CI 9	CI 12	CI 12	CI 6	CI 9	CI 16
	[AC value]	AC-3	AC-3	AC-3	AC-3	AC-1	AC-1	AC-1
Efficiency ³⁾		0.95						
Weight IP 20	[kg]	7	7	9	9	23	23	23
Weight IP 54	[kg]	11.5	11.5	13.5	13.5	35	35	38
Power loss at max. load. [W]	Total	76	95	126	172	194	426	545
	Enclosure	VLT type	Bookstyle IP 20/Compact IP 20/IP 54					

(Bookstyle IP 20 is available in power range VLT 6002-6005).

■ Mains supply 3 x 200 - 240 V

According to international requirements

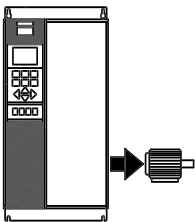

	VLT type	6016	6022	6027	6032	6042	6052	6062
Output current ⁴⁾	$I_{VLT,N}$ [A]	46.0	59.4	74.8	88.0	104	130	154
	$I_{VLT,MAX}$ (60 s) [A]	50.6	65.3	82.3	96.8	115	143	170
Output (240 V)	$S_{VLT,N}$ [kVA]	19.1	24.7	31.1	36.6	43.2	54.0	64.0
Typical shaft output	$P_{VLT,N}$ [kW]	11	15	18.5	22	30	37	45
Typical shaft output	$P_{VLT,N}$ [HP]	15	20	25	30	40	50	60
Max. cable cross-section to motor and DC-bus	[mm ² /AWG]	16/6	35/2	35/2	50/0	70/1/0	95/3/0	120/4/0
	Min. cable cross-section to motor and DC-bus	[mm ² /AWG]	10/8	10/8	10/8	16/6	10/8	10/8

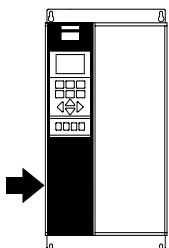

Max. input current (200 V)	$I_{L,N}$ [A]	46.0	59.2	74.8	88.0	101.3	126.6	149.9
Max. cable, cross-section, power	[mm ²]/[AWG]	16/6	35/2	35/2	50/0	70/1/0	95/3/0	120/4/0
	Max. pre-fuses	[A]/UL ¹⁾ [A]	60	80	125	125	150	200
Mains contactor	[Danfoss type]	CI 32	CI 32	CI 37	CI 45	-	-	-
	[AC value]	AC-1	AC-1	AC-1	AC-1			
Efficiency ³⁾		0.95						
Weight IP 00	[kg]	-	-	-	-	90	90	90
Weight IP 20	[kg]	23	30	30	48	101	101	101
Weight IP 54	[kg]	38	49	50	55	104	104	104
Power loss at max. load:	[W]	545	783	1042	1243	1089	1361	1613
Enclosure		IP 20+NEMA 1 kit, IP 54/NEMA 12						

1. If UL/cUL is to be complied with, pre-fuses type Bussmann KTN-R 200 V, KTS-R 500 V or similar must be used. In the remainder of the world, the first-mentioned pre-fuses must be used. These pre-fuses must be semi-conductor fuses of the gL type. The fuses must be placed to protect a circuit capable of supplying max. 100,000 amps rms (symmetrical), 500 V maximum.
2. American Wire Gauge.
3. Measured using 30 m screened/armoured motor cable at rated load and rated frequency.
4. Current ratings fulfill UL requirements for 208-240 V

■ Technical data, mains supply 3 x 380 - 460 V

According to international requirements

VLT type		6002	6003	6004	6005	6006	6008	6011
Output current	$I_{VLT,N}$ [A] (380-415 V)	3.0	4.1	5.6	7.2	10.0	13.0	16.0
	$I_{VLT,MAX}$ (60 s) [A] (380-415 V)	3.3	4.5	6.2	7.9	11.0	14.3	17.6
	$I_{VLT,N}$ [A] (440-460 V)	3.0	3.4	4.8	6.3	8.2	11.0	14.0
	$I_{VLT,MAX}$ (60 s) [A] (440-460 V)	3.3	3.7	5.3	6.9	9.0	12.1	15.4
Output	$S_{VLT,N}$ [kVA] (400 V)	2.2	2.9	4.0	5.2	7.2	9.3	11.5
	$S_{VLT,N}$ [kVA] (460 V)	2.4	2.7	3.8	5.0	6.5	8.8	11.2
Typical shaft output	$P_{VLT,N}$ [kW]	1.1	1.5	2.2	3.0	4.0	5.5	7.5
Typical shaft output	$P_{VLT,N}$ [HP]	1.5	2	3	-	5	7.5	10
Max. cable cross-section to motor	[mm ² /AWG]	4/10	4/10	4/10	4/10	4/10	4/10	4/10
Max. input current	$I_{L,N}$ [A] (380 V)	2.8	3.8	5.3	7.0	9.1	12.2	15.0
	$I_{L,N}$ [A] (460 V)	2.5	3.4	4.8	6.0	8.3	10.6	14.0
Max. cable cross-section, power	[mm ²]/[AWG] ²⁾	4/10	4/10	4/10	4/10	4/10	4/10	4/10
Max. pre-fuses	[A]/UL ¹⁾ [A]	16/6	16/10	16/10	16/15	25/20	25/25	35/30
Mains contactor	[Danfoss type]	CI 6	CI 6	CI 6	CI 9	CI 12	CI 5	CI 6
	[AC value]	AC-3	AC-3	AC-3	AC-3	AC-3	AC-1	AC-1
Efficiency ³⁾		0.96						
Weight IP 20	[kg]	8	8	8,5	8,5	10,5	10,5	10,5
Weight IP 54	[kg]	11.5	11.5	12	12	14	14	14
Power loss at max. load. [W]	Total	67	92	110	139	198	250	295
Enclosure	VLT type	Bookstyle IP 20/Compact IP 20/IP 54						
(Bookstyle IP 20 is available in the VLT 6002-6011 power range)								

■ Mains supply 3 x 380 - 460 V

According to international requirements

VLT type		6016	6022	6027	6032	6042	6052	6062
Output current	$I_{VLT,N}$ [A] (380-415 V)	24.0	32.0	37.5	44.0	61.0	73.0	90.0
	$I_{VLT,MAX}$ (60 s) [A] (380-415 V)	26.4	35.2	41.3	48.4	67.1	80.3	99.0
	$I_{VLT,N}$ [A] (440-460 V)	21.0	27.0	34.0	40.0	52.0	65.0	77.0
	$I_{VLT,MAX}$ (60 s) [A] (440-460 V)	23.1	29.7	37.4	44.0	57.2	71.5	84.7
Output	$S_{VLT,N}$ [kVA] (400 V)	17.3	23.0	27.0	31.6	43.8	52.5	64.7
	$S_{VLT,N}$ [kVA] (460 V)	16.7	21.5	27.1	31.9	41.4	51.8	61.3
Typical shaft output	$P_{VLT,N}$ [kW]	11	15	18.5	22	30	37	45
Typical shaft output	$P_{VLT,N}$ [HP]	15	20	25	30	40	50	60
Max. cable cross-section to motor and DC-bus	[mm ² /AWG]	16/6	16/6	16/6	16/6	35/2	35/2	50/0
Min. cable cross-section to motor and DC-bus ⁴⁾	[mm ² /AWG]	10/8	10/8	10/8	10/8	10/8	10/8	16/6
Max. input current	$I_{L,N}$ [A] (380 V)	32.0	32.0	37.5	44.0	60.0	72.0	89.0
	$I_{L,N}$ [A] (460 V)	27.6	27.6	34.0	41.0	53.0	64.0	77.0
Max. cable cross-section, power	[mm ²]/[AWG]	16/6	16/6	16/6	16/6	35/2	35/2	50/0
Max. pre-fuses	[A]/UL ¹⁾ [A]	63/40	63/40	63/50	63/60	80/80	100/100	125/125
Efficiency at rated frequency		0.96						
Weight IP 20	[kg]	23	23	23	30	30	48	48
Weight IP 54	[kg]	48	48	48	51	61	67	70
Power loss at max. load. [W]		419	559	655	768	1065	1275	1571
Enclosure		IP 20/IP 54						

1. If UL/cUL is to be complied with, pre-fuses type Bussmann KTS-R or similar must be used. In the remainder of the world, the first-mentioned pre-fuses must be used. These pre-fuses must be semi-conductor fuses of the gL type. The fuses must be placed to protect a circuit capable of supplying max. 100,000 amps rms (symmetrical), 500 V maximum.
2. American Wire Gauge.
3. Measured using 30 m screened/armoured motor cable at rated load and rated frequency.
4. Min. cable cross-section is the smallest cable cross-section allowed to be fitted on the terminals.
Always comply with national and local regulations on min. cable cross-section.

■ Technical data, mains supply 3 x 380 - 460 V

According to international requirements

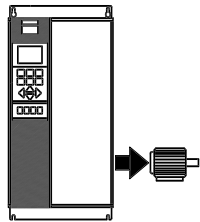

	VLT type	6075	6100	6125	6150	6175	6225	6275
Output current	$I_{VLT,N}$ [A] (380-415 V)	106	147	177	212	260	315	368
	$I_{VLT,MAX}$ (60 s) [A] (380-415 V)	117	162	195	233	286	347	405
	$I_{VLT,N}$ [A] (440-460 V)	106	130	160	190	240	302	361
	$I_{VLT,MAX}$ (60 s) [A] (440-460 V)	117	143	176	209	264	332	397
Output	$S_{VLT,N}$ [kVA] (400 V)	73	102	123	147	180	218	255
	$S_{VLT,N}$ [kVA] (460 V)	84,5	104	127	151	191	241	288
Typical shaft output (380-415 V)	$P_{VLT,N}$ [kW]	55	75	90	110	132	160	200
Typical shaft output (440-460 V)	$P_{VLT,N}$ [HP]	75	100	125	150	200	250	300
Max. cross-section of copper cable to motor and DC-bus (380-415 V)	[mm ²]	70	95	120	2x70	2x70	2x95	2x120
Max. cross-section of copper cable to motor and DC-bus (440-460 V)	[mm ²]	70	70	95	2x70	2x70	2x95	2x120
Max. cross-section of aluminium cable to motor and DC-bus (380-415 V)	[mm ²]	95	90	120	2x70	2x95	2x120	2x150
Max. cross-section of aluminium cable to motor and DC-bus (440-460 V)	[mm ²]	70	120	150	2x70	2x120	2x120	2x150
Max. cross-section of copper cable to motor and DC-bus (380-415 V)	[AWG]	1/0	3/0	4/0	2x1/0	2x2/0	2x3/0	2x250mcm
Max. cross-section of copper cable to motor and DC-bus (440-460 V)	[AWG]	1/0	2/0	3/0	2x1/0	2x1/0	2x3/0	2x4/0
Max. cross-section of aluminium cable to motor and DC-bus (380-415 V)	[AWG]	3/0	250mcm	300mcm	2x2/0	2x4/0	2x250mcm	2x350mcm
Max. cross-section of aluminium cable to motor and DC-bus (440-460 V)	[AWG]	3/0	4/0	250mcm	2x2/0	2x3/0	2x250mcm	2x300mcm
Max. cross-section of cable to motor, and DC-bus ⁴⁾	[mm ² /AWG]	10/8	10/8	10/8	10/8	10/8	16/6	16/6

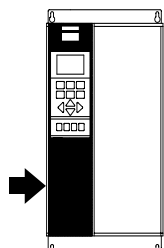

Max. input current	$I_{L,N}$ [A] (400 V)	131	155	217	262	310	384	476
	$I_{L,N}$ [A] (460 V)	117	155	192	236	277	355	457
Max. cross-section of copper cable to power (380-415 V)	[mm ²]	70	95	120	2x70	2x70	2x95	2x120
Max. cross-section of copper cable to power (440-460 V)	[mm ²]	70	70	95	2x70	2x70	2x95	2x120
Max. cross-section of aluminium cable to power (380-415 V)	[mm ²]	95	90	120	2x70	2x95	2x120	2x150
Max. cross-section of aluminium cable to power (440-460 V)	[mm ²]	70	120	150	2x70	2x120	2x120	2x150
Max. cross-section of copper cable to power (380-415 V)	[AWG]	1/0	3/0	4/0	2x1/0	2x2/0	2x3/0	2x250mcm
Max. cross-section of copper cable to power (440-460 V)	[AWG]	1/0	2/0	3/0	2x1/0	2x1/0	2x3/0	2x4/0
Max. cross-section of aluminium cable to power (380-415V)	[AWG]	3/0	250mcm	300mcm	2x2/0	2x4/0	2x250mcm	2x350mcm
Max. cross-section of aluminium cable to power (440-460 V)	[AWG]	3/0	4/0	250mcm	2x2/0	2x3/0	2x250mcm	2x300mcm
Min. cable cross-section to motor, and DC-bus ⁴⁾	[mm ² /AWG]	10/8	10/8	10/8	10/8	10/8	16/6	
Max. pre-fuses	[A]/UL ¹⁾ [A]	150/150	250/220	250/250	300/300	350/350	450/400	500/500
Integral pre-fuses	[A]/UL ¹⁾ [A]	15/15	15/15	15/15	30/30	30/30	30/30	30/30
Pre-fuses SMPS	[A]/UL ¹⁾ [A]	5.0/5.0						
Weight IP 00	[kg]	109	109	109	146	146	146	146
Weight IP 20	[kg]	121	121	121	161	161	161	161
Weight IP 54	[kg]	124	124	124	177	177	177	177
Efficiency at rated frequency		0.96-0.97						
Power loss at max. load	[W]	1430	1970	2380	2860	3810	4770	5720
Enclosure		IP 00 / IP 20/ IP 54						

1. If UL/cUL is to be complied with, pre-fuses type Bussmann KTN-R, KTS-R or similar must be used. In the remainder of the world, the first-mentioned pre-fuses must be used. These pre-fuses must be semi-conductor fuses of the gL type. The fuses must be placed to protect a circuit capable of supplying max. 100,000 amps rms (symmetrical), 500 V maximum.
2. American Wire Gauge.
3. Measured using 30 m screened/armoured motor cable at rated load and rated frequency.
4. Min. cable cross-section is the smallest cable cross-section allowed to be fitted on the terminals. Always comply with national and local regulations on min. cable cross-section.

■ Mechanical dimensions

All measurements in mm.

VLT type	A	B	C		a	b	a/b	Type
Bookstyle IP 20 200-240 V								
6002 - 6003	395	90	260		384	70	100	A
6004 - 6005	395	130	260		384	70	100	A
Bookstyle IP 20 380-460 V								
6002 - 6005	395	90	260		384	70	100	A
6006 - 6011	395	130	260		384	70	100	A
IP 00 200-240 V								
6042 - 6062	800	370	335		780	270	250	B
IP 00 380-460 V								
6075 - 6125	800	370	335		780	270	250	B
6150 - 6275	1400	420	400		1380	350	300	B
IP 20 200-240 V								
6002 - 6003	395	220	160		384	200	100	C
6004 - 6005	395	220	200		384	200	100	C
6006 - 6011	560	242	260		540	200	200	D
6016 - 6022	700	242	260		680	200	200	D
6027 - 6032	800	308	296		780	270	200	D
6042 - 6062	975	370	335		780	270	250	E
IP 20 380-460 V								
6002 - 6005	395	220	160		384	200	100	C
6006 - 6011	395	220	200		384	200	100	C
6016 - 6027	560	242	260		540	200	200	D
6032 - 6042	700	242	260		680	200	200	D
6052 - 6062	800	308	296		780	270	200	D
6075 - 6125	975	370	335		780	270	250	E
6150 - 6275	1575	420	400		1380	350	300	E
VLT type	A	B	C	D	a	b	a/b	Type
IP 54 200-240 V								
6002 - 6003	460	282	195	85	260	258	100	F
6004 - 6005	530	282	195	85	330	258	100	F
6006 - 6011	810	355	280	70	560	330	200	F
6016 - 6032	940	400	280	70	690	375	200	F
6042 - 6062	937	495	421	-	830	374	250	G
IP 54 380-460 V								
6002 - 6005	460	282	195	85	260	258	100	F
6006 - 6011	530	282	195	85	330	258	100	F
6016 - 6032	810	355	280	70	560	330	200	F
6042 - 6062	940	400	280	70	690	375	200	F
6075 - 6125	937	495	421	-	830	374	250	G
6150 - 6275	1572	495	425	-	1465	445	300	G
Option for IP 00 VLT 6075-6275	A1	B1	C1					
IP 20 bottom cover								
6075 - 6125	175	370	335					
6150 - 6275	175	420	400					

a: Min. air above enclosure

b: Min. air below enclosure

■ Mechanical dimensions

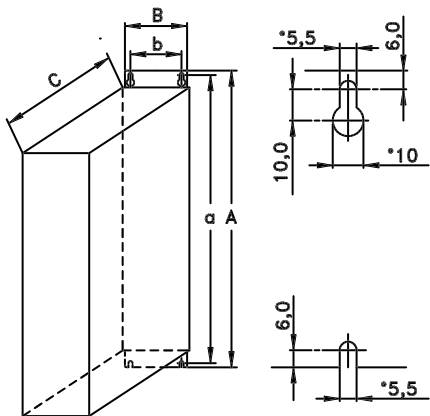

Type A, IP20

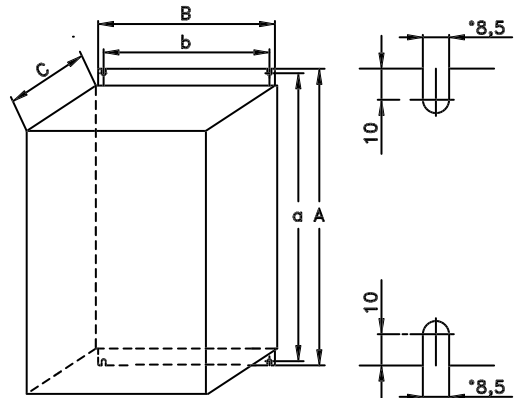

Type D, IP20

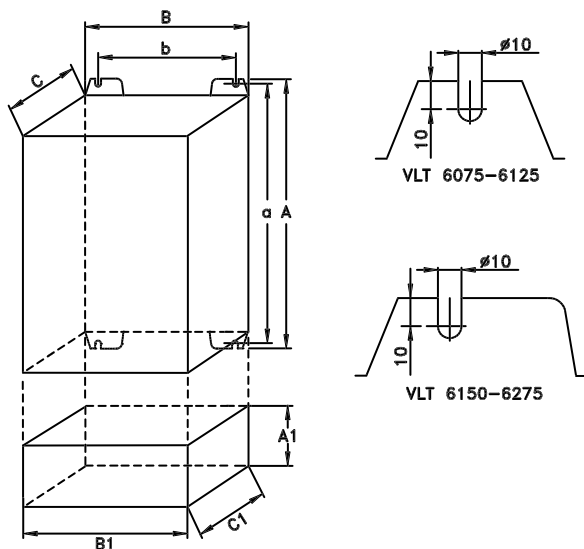

Type B, IP00
With option and enclosure IP20

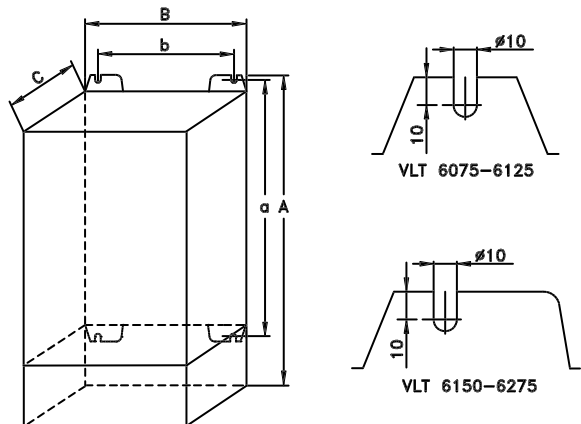

Type E, IP20

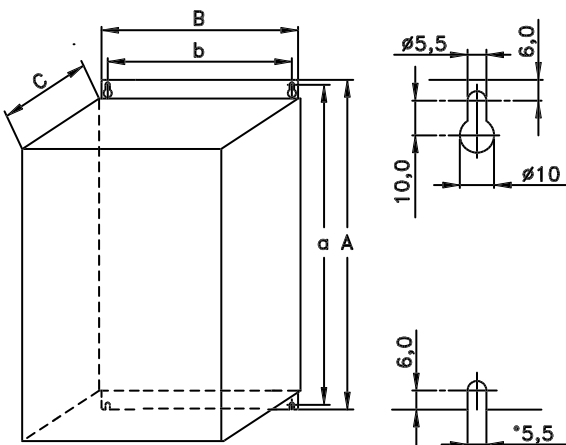

Type C, IP20

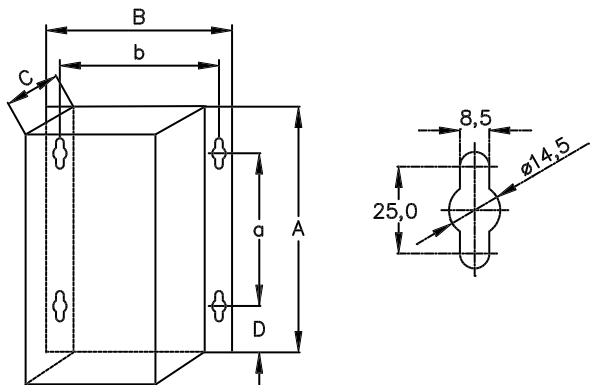

Type F, IP54

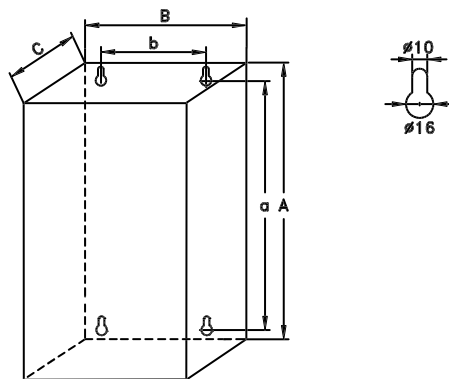

Type G, IP54

■ Mechanical installation



Please pay attention to the requirements that apply to integration and field mounting kit, see the below list. The

information given in the list must be observed to avoid serious damage or injury, especially when installing large units.

The VLT frequency converter *must* be installed vertically.

The VLT frequency converter is cooled by means of air circulation. For the unit to be able to release its cooling air, the *minimum* distance over and below the unit must be as shown in the illustration below.

To protect the unit from overheating, it must be ensured that the ambient temperature *does not rise above the max. temperature stated for the VLT frequency converter* and that the 24-hour average temperature *is not exceeded*. The max. temperature and 24-hour average can be seen from the General Technical Data on page 42.

If the ambient temperature is in the range of 45°C - 55°C, derating of the VLT frequency converter will become relevant, see the diagram on page 160.

The service life of the VLT frequency converter will be reduced if derating for ambient temperature is not taken into account.

■ Enclosure protection

	IP 00	IP 20	IP 54
Bookstyle	-	OK	-
VLT 6002-6032 200-240 V	-	OK	OK
VLT 6002-6275 380-460 V	OK	OK	OK

■ Field-mounting

	IP 00	IP 20	IP 54
Bookstyle	-	No	-
VLT 6002-6032 200-240 V	-	No	OK
VLT 6002-6275 380-460 V	No	No	OK

IP 20 with 4x top cover

VLT 6002-6005 200-240 V	-	OK	OK
VLT 6002-6016 380-460 V	-	OK	OK

IP 20 terminal cover

VLT 6006-6032 200-240 V	-	OK	OK
VLT 6022-6062 380-460 V	-	OK	OK

■ Spacing when installing of VLT 6002-6005 200-240 V, VLT 6002-6011 380-460 V Bookstyle IP 20, Compact IP 20 and IP 54.

Cooling

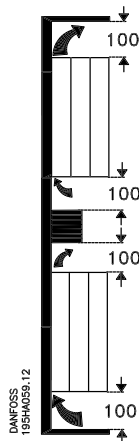

All the above-mentioned units require a minimum of 100 mm air above and below the enclosure.

Side-by-side

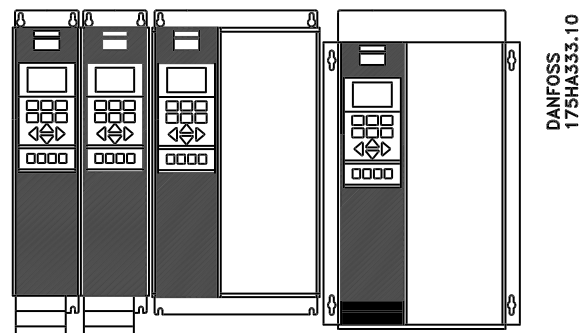

All the above-mentioned units can be installed side by side without any space, since these units do not require any cooling on the sides.

■ Installation of VLT 6006-6032 200-240 V, VLT 6016-6062 380-460 V IP 20 and IP 54 Cooling

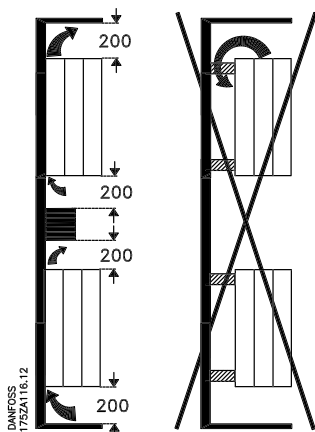

Side-by-side

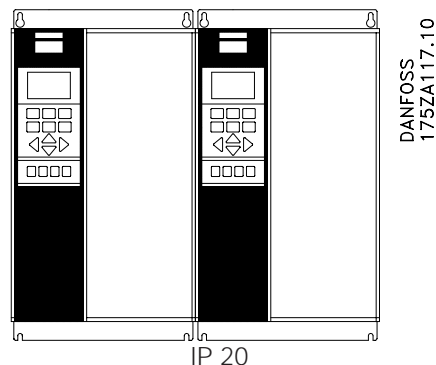

IP 20

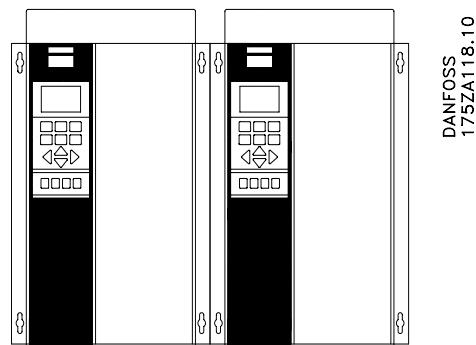

IP 54 (flange-by-flange)

All units in the above-mentioned series require a minimum of 200 mm of air above and below the enclosure and must be installed on a plane, vertical surface (no spacers). This applies both to IP 20 and IP 54 units.

These units can be installed side by side without any spacing, since they do not require any cooling on the sides.

■ Installation of VLT 6042-6062 200-240 V, VLT 6075-6275 380-460 V IP 00, IP 20 and IP 54 Cooling

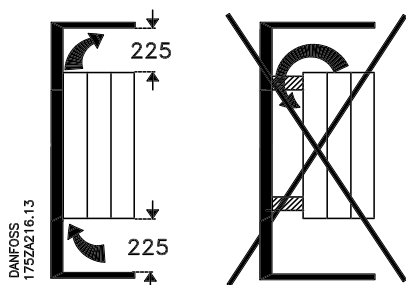

VLT 6075-6125

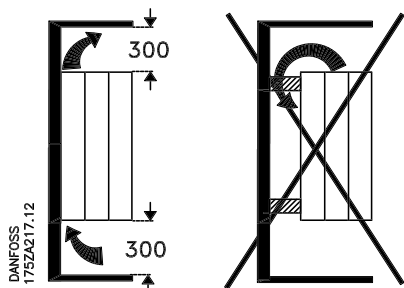

VLT 6150-6275

Side-by-side

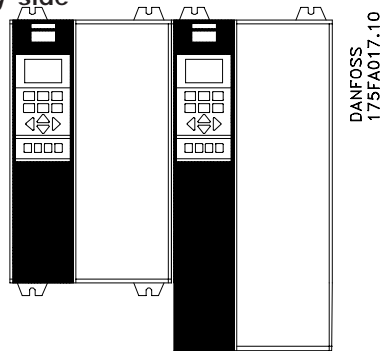

VLT 6075-6275 IP 00 and IP 20

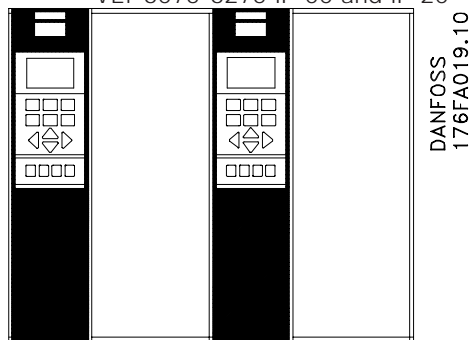

VLT 6075-6275 IP 54

All units in the above-mentioned series require the minimum of air shown above and below the enclosure and must be installed on a plane, vertical surface (no spacers). This applies to IP 00, IP 20 and IP 54 units alike.

All IP 00 and IP 20 units in the above-mentioned series can be installed side by side without any spacing.

■ General information about electrical installation

■ High voltage warning



The voltage of the frequency converter is dangerous whenever the equipment is connected to mains. Incorrect installation of the motor or the frequency converter may cause damage to the equipment, serious personal injury or death.

Consequently, the instructions in this Design Guide, as well as national and local safety regulations, must be complied with.

Touching the electrical parts may be fatal - even after disconnection from mains:

Using VLT 6002-6005 wait at least 4 minutes and using VLT 6006-6275 wait at least 15 minutes.



NB!

It is the user's or certified electrician's responsibility to ensure correct earthing and protection in accordance with applicable national and local norms and standards.

■ Earthing

The following basic issues need to be considered when installing a frequency converter, so as to obtain electromagnetic compatibility (EMC).

- **Safety earthing:** Please note that the frequency converter has a high leakage current and must be earthed appropriately for safety reasons. Apply local safety regulations.
- **High-frequency earthing:** Keep the earth wire connections as short as possible.

Connect the different earth systems at the lowest possible conductor impedance. The lowest possible conductor impedance is obtained by keeping the conductor as short as possible and by using the greatest possible surface area. A flat conductor, for example, has a lower HF impedance than a round conductor for the same conductor cross-section C_{VESS} .

If more than one device is installed in cabinets, the cabinet rear plate, which must be made of metal, should be used as a common earth reference plate. The metal cabinets of the different devices are mounted on the cabinet rear plate using the lowest possible HF impedance. This avoids having different HF voltages for the individual devices and avoids the risk of radio interference currents running in connection cables that may be used between the devices. The radio interference will have been reduced.

In order to obtain a low HF impedance, use the fastening bolts of the devices as HF connection to the rear plate. It is necessary to remove insulating paint or similar from the fastening points.

■ Cables

Control cables and the filtered mains cable should be installed separate from the motor cables so as to avoid interference overcoupling. Normally, a distance of 20 cm will be sufficient, but it is recommended to keep the greatest possible distance wherever possible, especially where cables are installed in parallel over a substantial distance.

With respect to sensitive signal cables, such as telephone cables and data cables, the greatest possible distance is recommended with a minimum of 1 m per 5 m of power cable (mains and motor cable). It must be pointed out that the necessary distance depends on the sensitivity of the installation and the signal cables, and that therefore no precise values can be stated.

If cable jaws are used, sensitive signal cables are not to be placed in the same cable jaws as the motor cable or brake cable.

If signal cables are to cross power cables, this should be done at an angle of 90 degrees.

Remember that all interference-filled in- or outgoing cables to/from a cabinet should be screened/armoured or filtered.

See also *EMC-correct electrical installation*.

■ Screened/armoured cables

The screen must be a low HF-impedance screen. This is ensured by using a braided screen of copper, aluminium or iron. Screen armour intended for mechanical protection, for example, is not suitable for an EMC-correct installation.

See also *Use of EMC-correct cables*.

■ Extra protection

ELCB relays, multiple protective earthing or earthing can be used as extra protection, provided that local safety regulations are complied with.

In the case of an earth fault, a DC content may develop in the faulty current.

Never use ELCB relays, type A, since such relays are not suitable for DC fault currents. If ELCB relays are used, this must be done in accordance with local regulations.

If ELCB relays are used, they must be:

- Suitable for protecting equipment with a direct current content (DC) in the faulty current (3-phase bridge rectifier)
- Suitable for power-up with short charging current to earth
- Suitable for a high leakage current.

■ RFI switch

Mains supply isolated from earth:

When the VLT frequency converter is supplied from an isolated mains source (IT mains), the RFI switch must be closed (OFF). In the OFF position, the internal RFI capacitors (filter capacitors) between the chassis and the intermediate circuit are cut out so as to avoid damaging the intermediate circuit and to reduce the earth leakage currents (see IEC 1800-3).

The position of the RFI switch can be seen from pages 57-59.



NB!

When the RFI switch is set to OFF parameter 407 *Switching frequency* max is allowed to be set to factory setting.



NB!

The VLT 6011/460 V has no RFI switch, since the factory setting is ON.



NB!

The RFI switch is not to be operated with mains supply connected to the unit. Check that the mains supply has been disconnected before operating the RFI switch.



NB!

The RFI switch disconnects the capacitors galvanically; however, transients higher than approx. 1,000 V will be bypassed by a spark gap.



Reliable galvanic isolation (PELV) is lost if the RFI switch is placed in the OFF position. This means that all control in- and outputs can no longer be considered low-voltage terminals. In addition, the VLT 6000 HVAC EMC performance will be reduced if the RFI switch is placed in the OFF position.

Mains supply connected to earth:

The RFI switch must be ON for all installations on earthed mains supplies.

■ High voltage test

A high voltage test can be carried out by short-circuiting terminals U, V, W, L₁, L₂ and L₃ and energizing by max. 2.5 kV DC for one second between this short-circuit and the chassis.



NB!

The RFI switch must be closed (position ON) when high voltage tests are carried out.

The mains and motor connection must be interrupted in the case of high voltage tests of the total installation if the leakage currents are too high.

■ Heat emission from VLT 6000 HVAC

The tables on page 45-47 show the power loss P_φ(W) from VLT 6000 HVAC. The maximum cooling air temperature t_{IN, MAX} is 40° at 100% load (of rated value).

■ Ventilation of integrated VLT 6000 HVAC

The quantity of air required for cooling frequency converters can be calculated as follows:

1. Add up the values of P_φ for all the frequency converters to be integrated in the same panel. The highest cooling air temperature (t_{IN}) present must be lower than t_{IN, MAX} (40°C). The day/night average must be 5°C lower (VDE 160). The outlet temperature of the cooling air must not exceed: t_{OUT, MAX} (45° C).
2. Calculate the permissible difference between the temperature of the cooling air (t_{IN}) and its outlet temperature (t_{OUT}):
Δt= 45° C-t_{IN}.
3. Calculate the required

$$\text{quantity of air} = \frac{\sum P_{\phi} \times 3.1}{\Delta t} \quad \text{m}^3/\text{h}$$

Insert Δt in Kelvin

The outlet from the ventilation must be placed above the highest-mounted frequency converter. Allowance must be made for the pressure loss across the filters and for the fact that the pressure is going to drop as the filters are choked.

■ EMC-correct electrical installation

General points to be observed to ensure EMC-correct electrical installation:

- Use only screened/armoured motor cables and screened/armoured control cables.
- Connect the screen to earth at both ends.
- Avoid installation with twisted screen ends (pigtailed), since this ruins the screening effect at high frequencies. Use cable clamps instead.
- It is important to ensure good electrical contact from the installation plate through the installation screws to the metal cabinet of the VLT frequency converter.
- Use toothed discs and galvanically conductive installation plates.
- Do not use unscreened/unarmoured motor cables in the installation cabinets.

The illustration below shows EMC-correct electrical installation; the VLT frequency converter has been fitted in an installation cabinet and connected to a PLC.

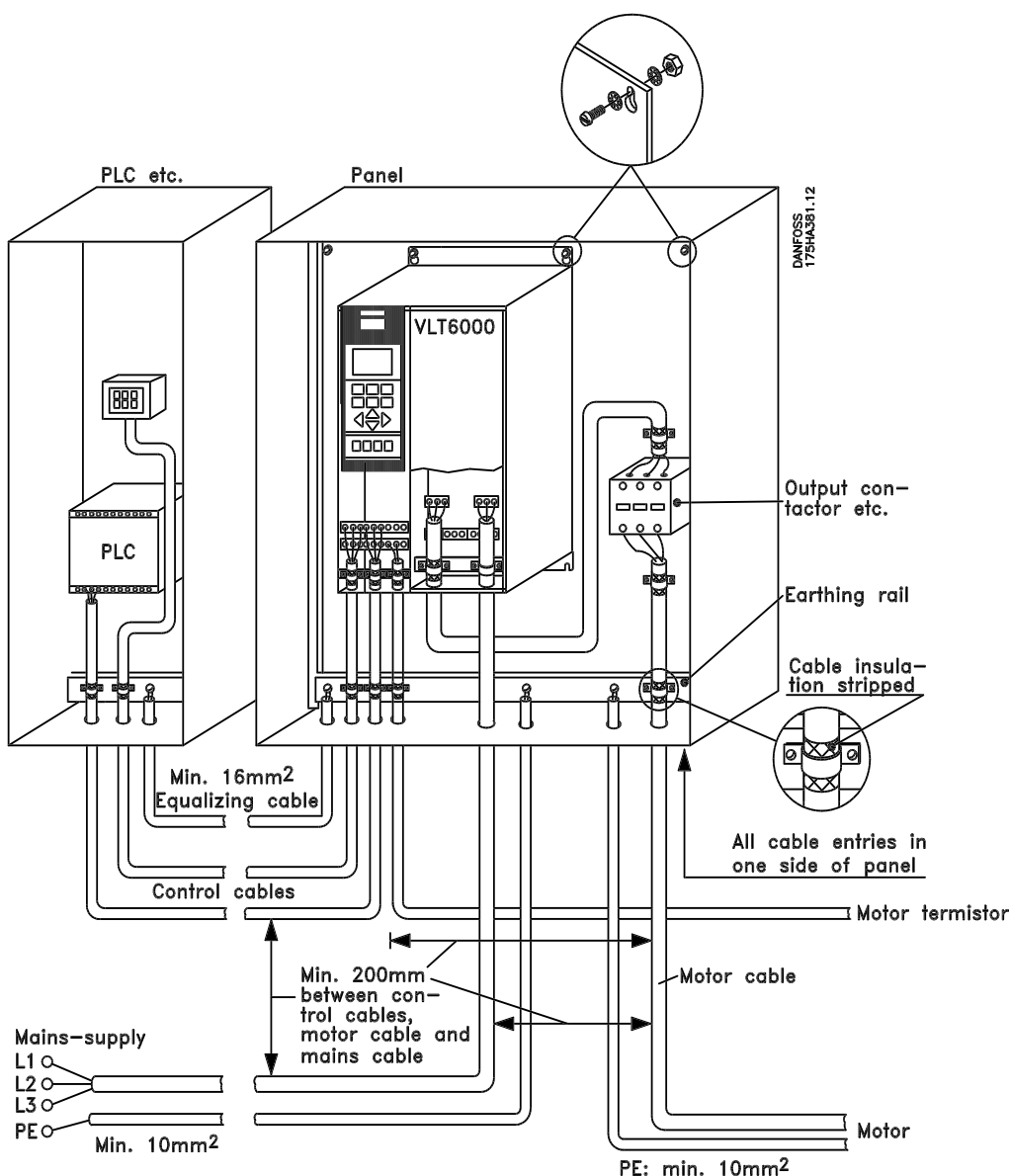

■ Use of EMC-correct cables

Screened/armoured cables are recommended to optimise EMC immunity of the control cables and the EMC emission from the motor cables.

The ability of a cable to reduce the in- and outgoing radiation of electric noise depends on the switching impedance (Z_T). The screen of a cable is normally designed to reduce the transfer of electric noise; however, a screen with a lower Z_T value is more effective than a screen with a higher Z_T . Z_T is rarely stated by cable manufacturers, but it is possible to estimate Z_T by looking at the cable and assessing its physical design.

Z_T can be assessed on the basis of the following factors:

- The contact resistance between the individual screen conductors.
- The screen coverage, i.e. the physical area of the cable covered by the screen - often stated as a percentage value. Should be min. 85%.
- The screen type, i.e. braided or twisted pattern. A braided pattern or a closed tube is recommended.

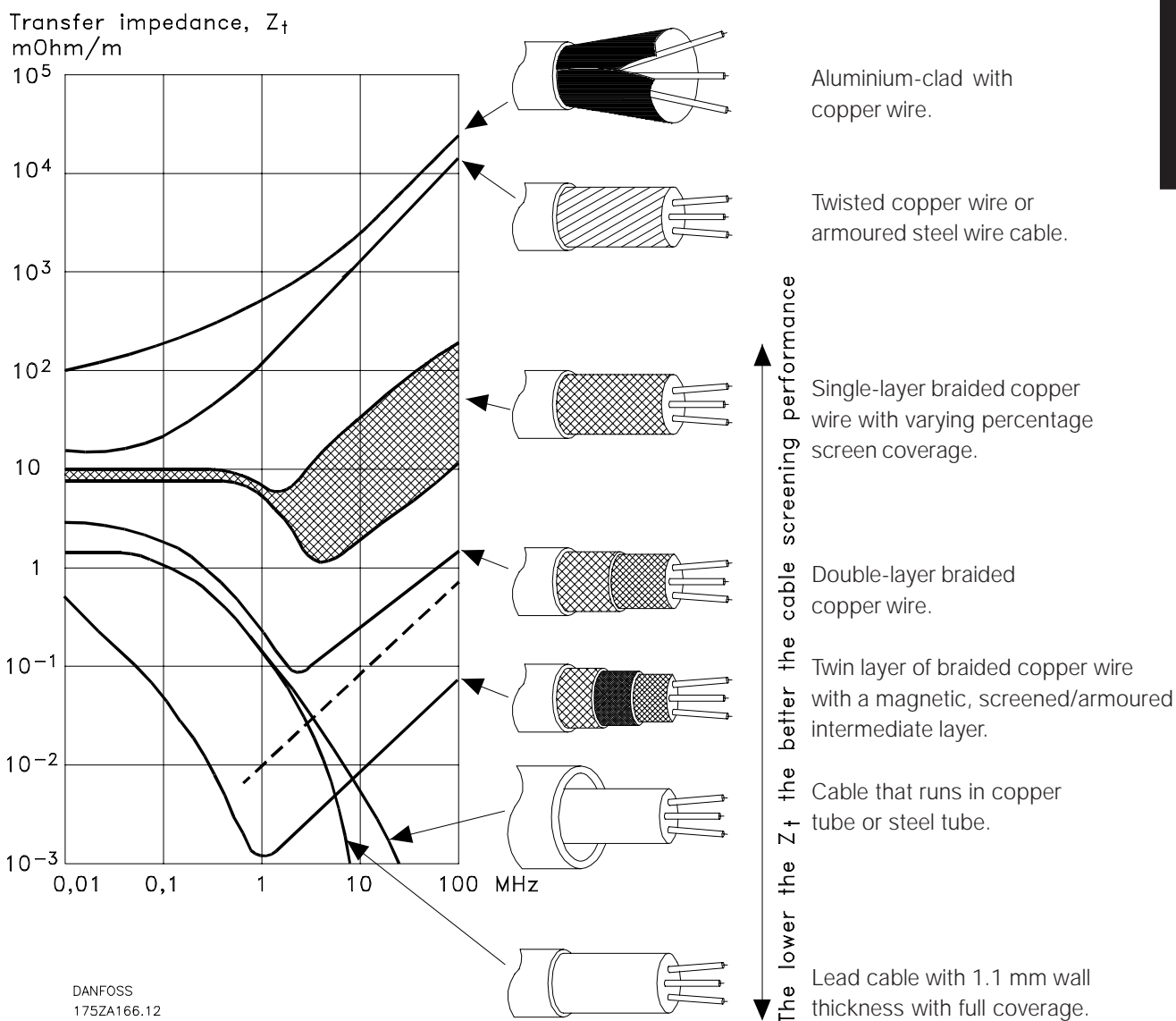

■ Earthing of screened/armoured control cables

Generally speaking, control cables must be screened/armoured and the screen must be connected by means of a cable clamp at both ends to the metal cabinet of the unit.

The drawing below indicates how correct earthing is carried out and what to be done if in doubt.

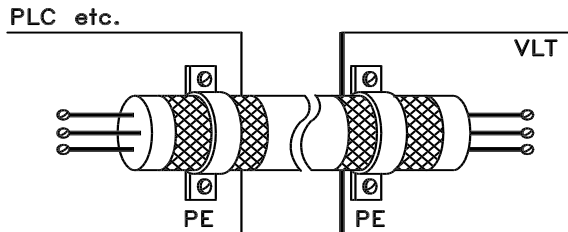

Correct earthing

Control cables and cables for serial communication must be fitted with cable clamps at both ends to ensure the best possible electrical contact.

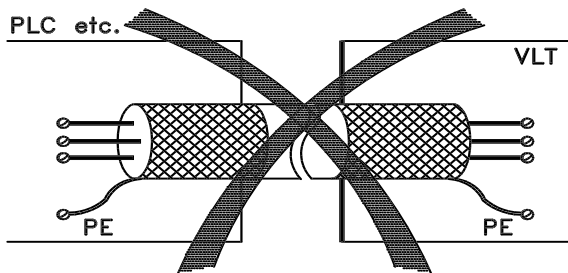

Wrong earthing

Do not use twisted cable ends (pigtailed), since these increase the screen impedance at high frequencies.

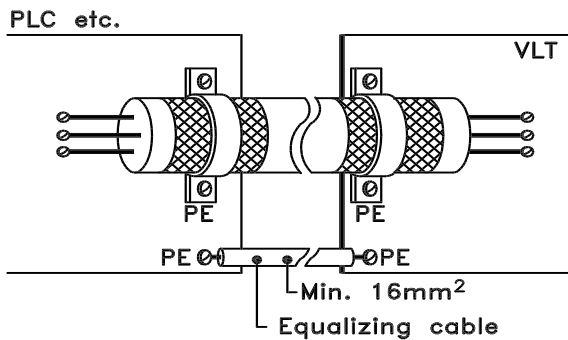

Protection with respect to earth potential between PLC and VLT

If the earth potential between the VLT frequency converter and the PLC (etc.) is different, electric noise may occur that will disturb the whole system. This problem can be solved by fitting an equalizing cable, to be placed next to the control cable. Minimum cable cross-section: 16 mm².

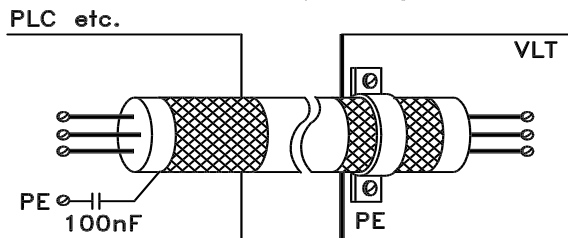

For 50/60 Hz earth loops

If very long control cables are used, 50/60 Hz earth loops may occur that will disturb the whole system. This problem can be solved by connecting one end of the screen to earth via a 100nF condenser (keeping leads short).

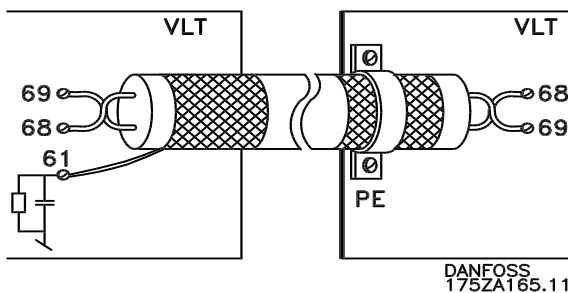

Cables for serial communication

Low-frequency noise currents between two VLT frequency converters can be eliminated by connecting one end of the screen to terminal 61. This terminal is connected to earth via an internal RC link. It is recommended to use twisted-pair cables to reduce the differential mode interference between the conductors.

DANFOSS
175ZA165.11

■ VLT 6000 HVAC enclosures

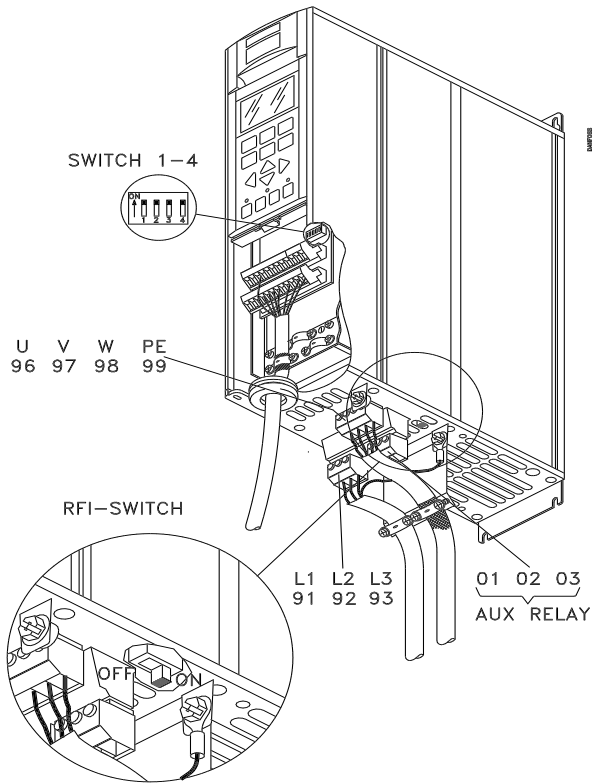

Bookstyle IP 20
VLT 6002-6005, 200-240 V
VLT 6002-6011, 380-460 V

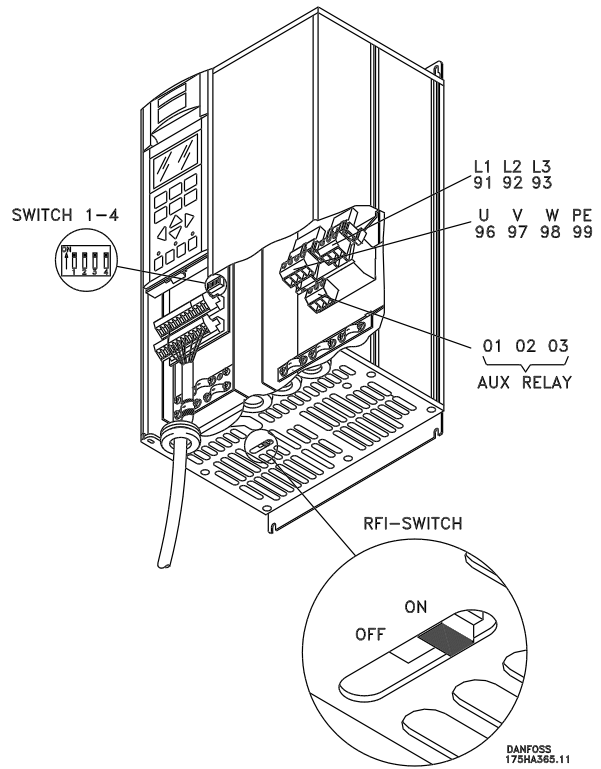

Compact IP 20
VLT 6002-6005, 200-240 V
VLT 6002-6011, 380-460 V

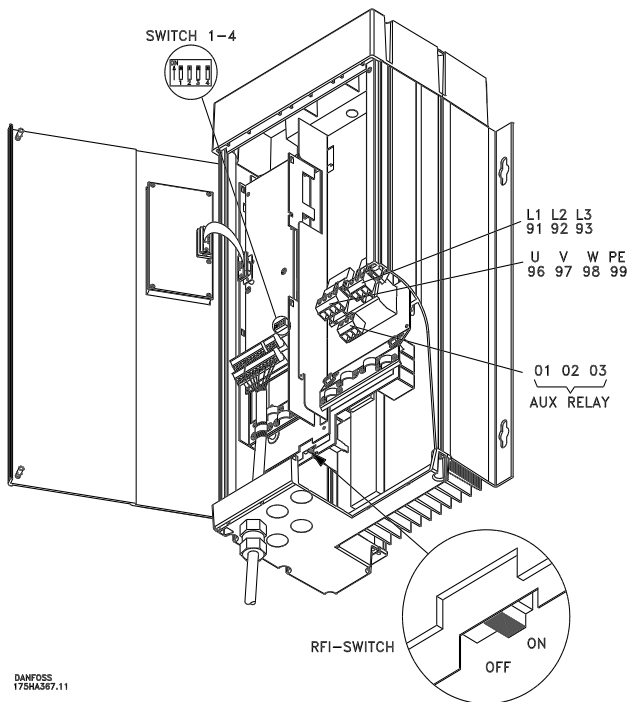

Compact IP 54
VLT 6002-6005, 200-240 V
VLT 6002-6011, 380-460 V

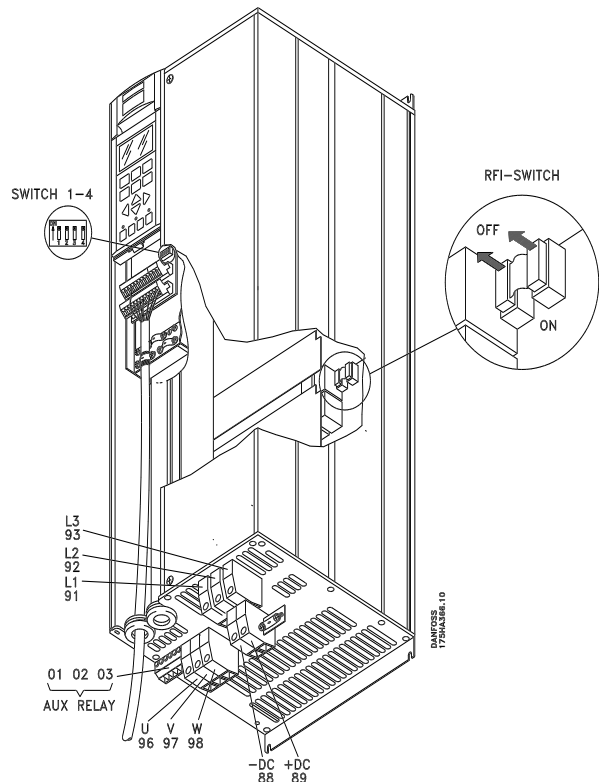

IP 20
VLT 6006-6032, 200-240 V
VLT 6016-6062, 380-460 V

■ VLT 6000 HVAC enclosures

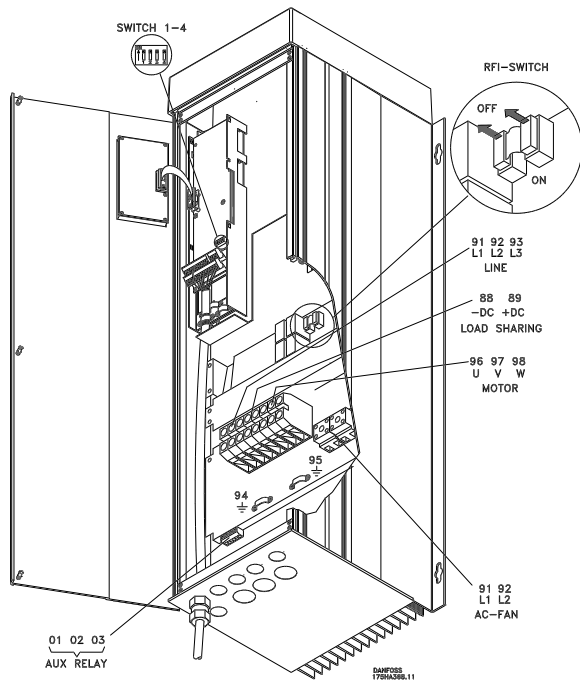

IP 54

VLT 6006-6032, 200-240 V
VLT 6016-6062, 380-460 V

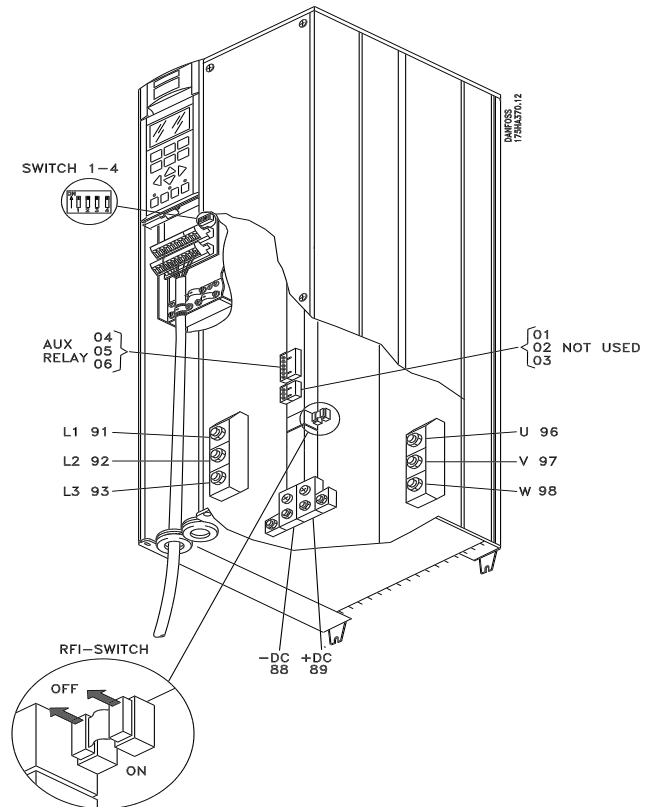

IP 00

VLT 6042-6062, 200-240 V
VLT 6075-6125, 380-460 V

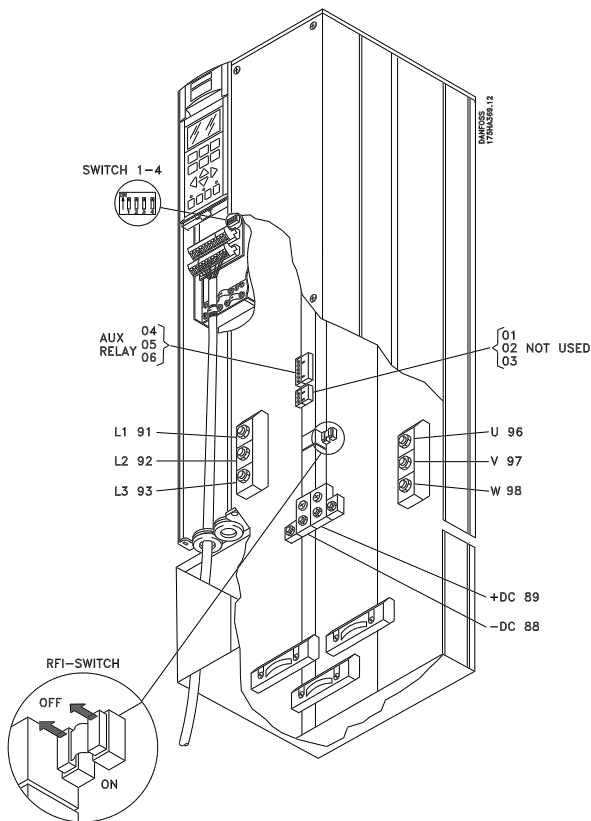

IP 20

VLT 6042-6062, 200-240 V
VLT 6075-6125, 380-460 V

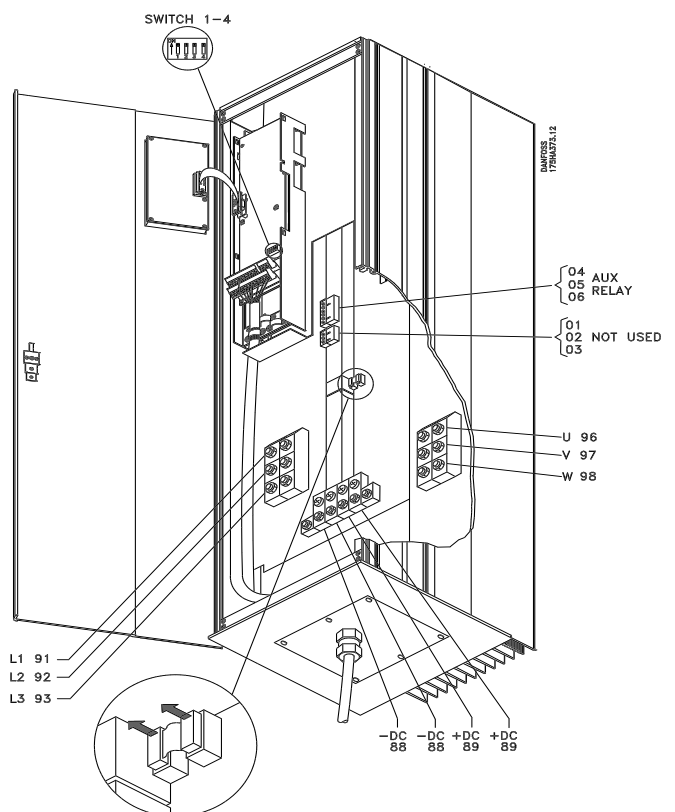

IP 54

VLT 6042-6062, 200-240 V
VLT 6075-6125, 380-460 V

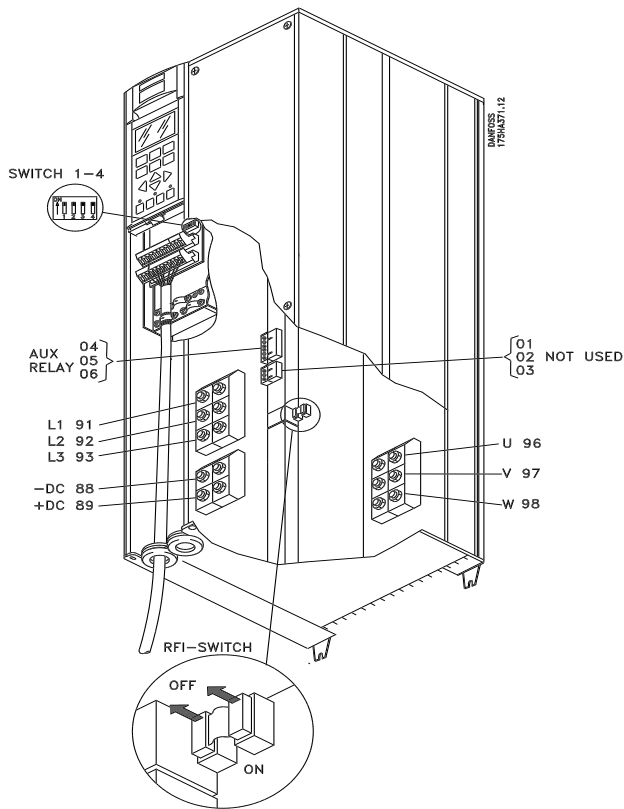

IP 00
VLT 6150-6275, 380-460 V

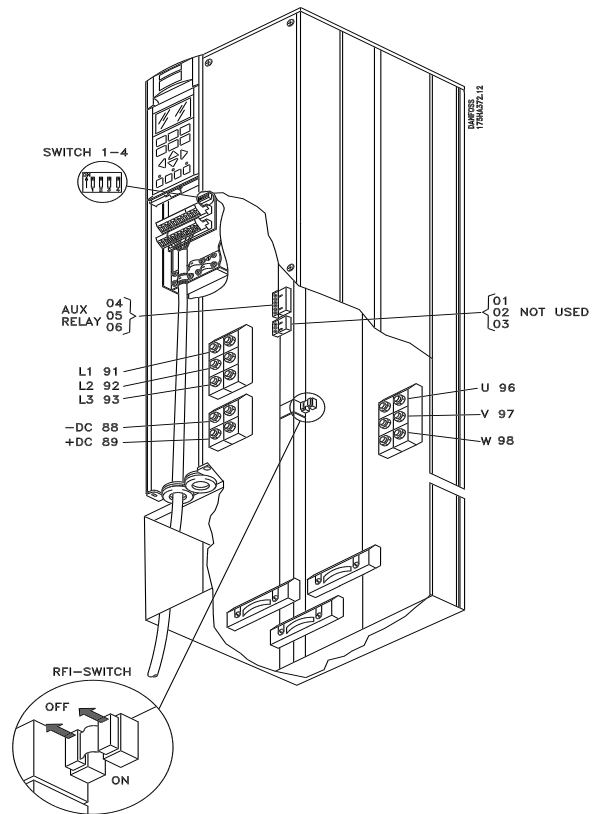

IP 20
VLT 6150-6275, 380-460 V

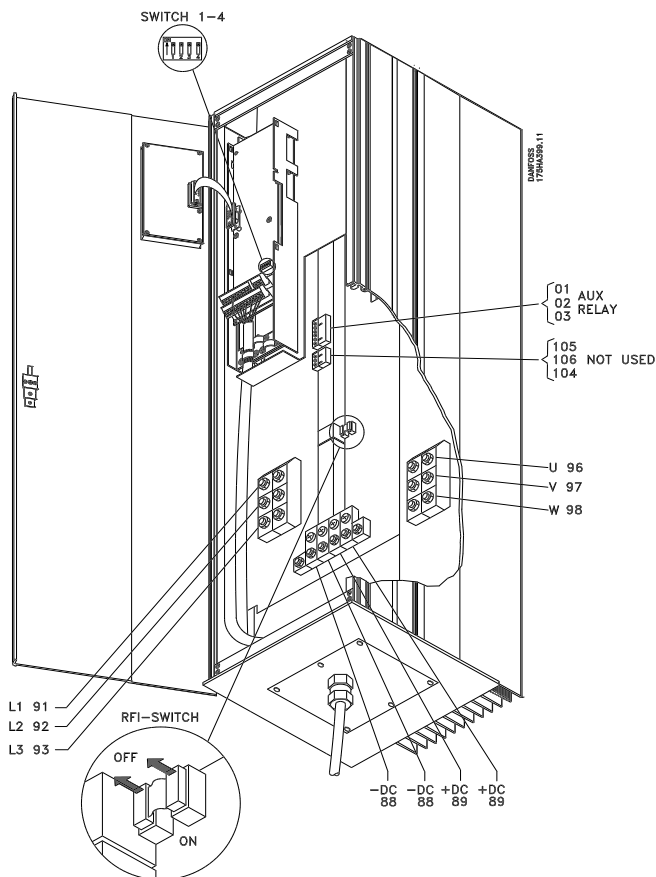

IP 54
VLT 6150-6275, 380-460 V

■ Electrical installation, power cables

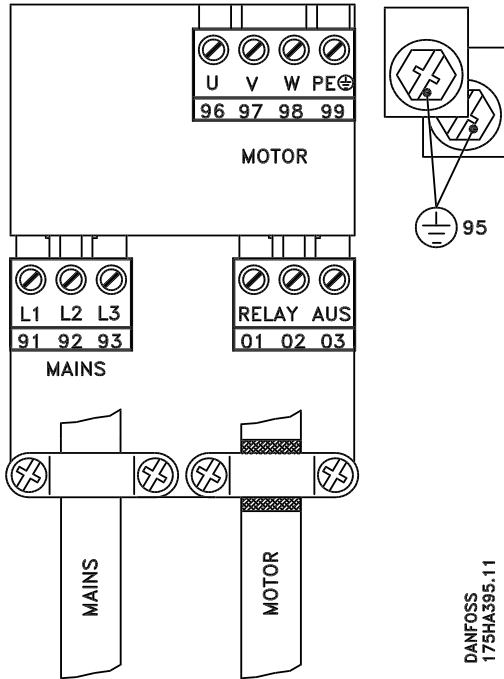

Bookstyle IP 20
VLT 6002-6005, 200-240 V
VLT 6002-6011, 380-460 V

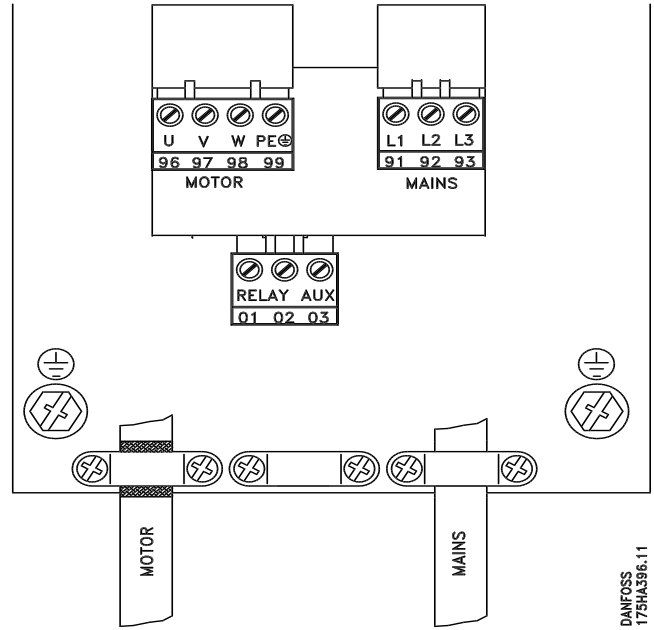

Compact IP 20/IP 54
VLT 6002-6005, 200-240 V
VLT 6002-6011, 380-460 V

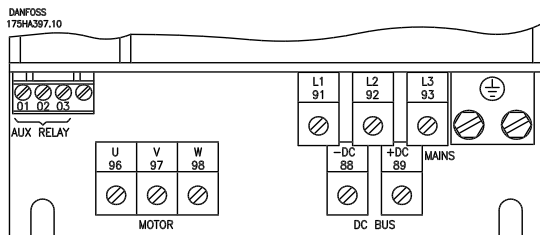

IP 20
VLT 6006-6032, 200-240 V
VLT 6016-6062, 380-460 V

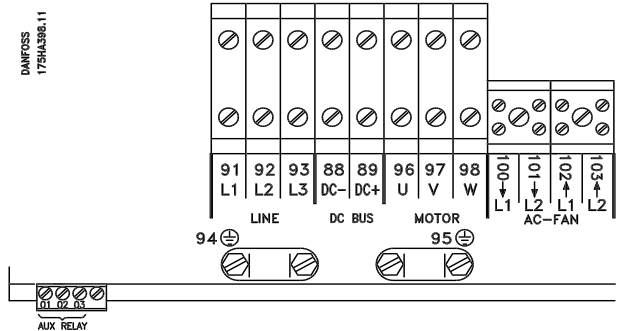

IP 54
VLT 6006-6032, 200-240 V
VLT 6016-6062, 380-460 V

■ Electrical installation, power cables

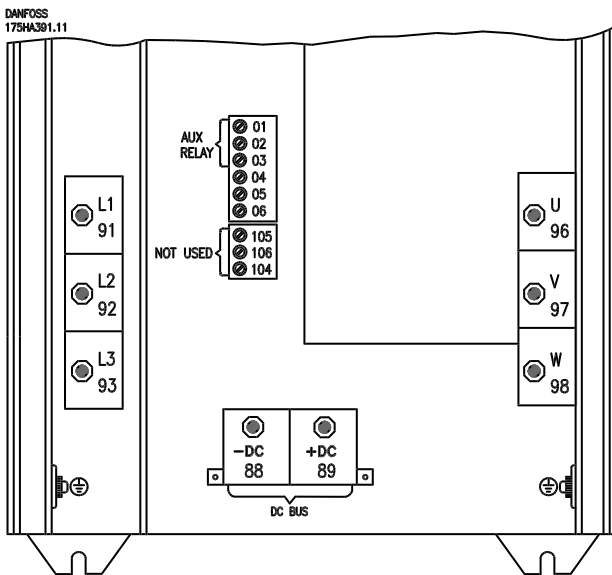

IP 00/20
VLT 6042-6062, 200-240 V
VLT 6075-6125, 380-460 V

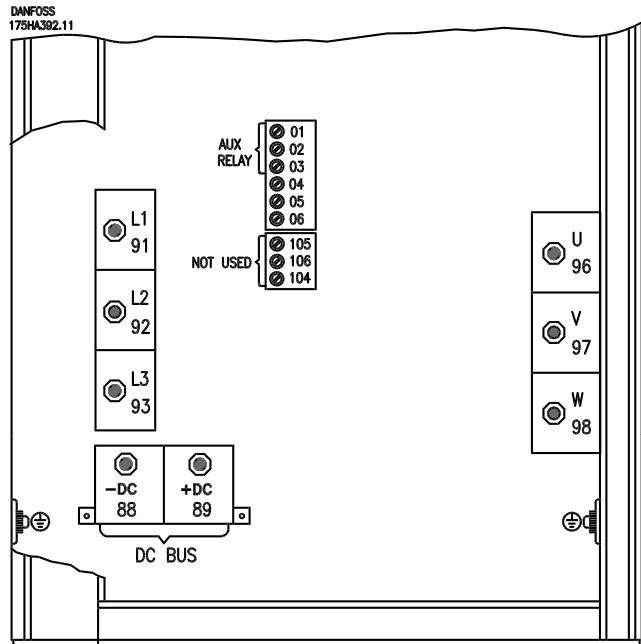

IP 54
VLT 6042-6062, 200-240 V
VLT 6075-6125, 380-460 V

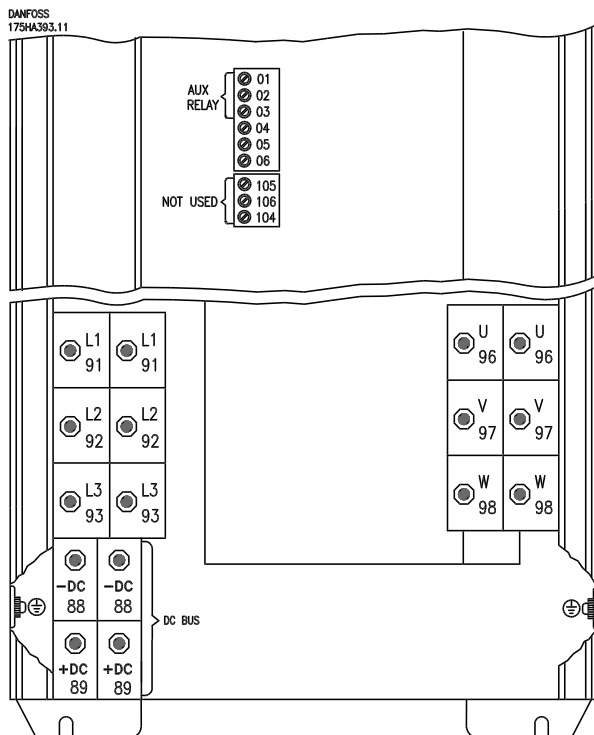

IP 00/20
VLT 6150-6275, 380-460 V

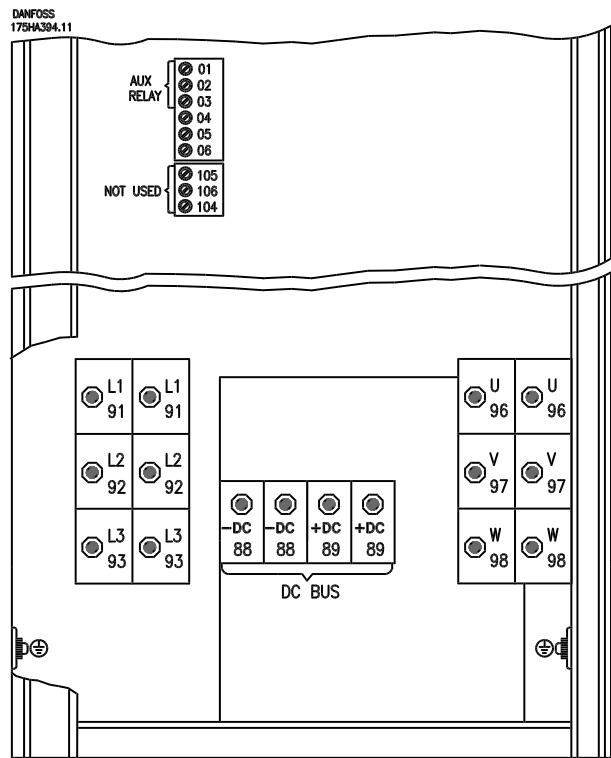

IP 54
VLT 6150-6275, 380-460 V

■ Tightening-up torque and screw sizes

The table shows the torque required when fitting terminals to the VLT frequency converter. For VLT 6002-6032, 200 -240 V, VLT 6002-6062, 380-460 V the cables must be fastened with screws. For VLT 6042-6062, 200-240 V and for VLT 6075-6275 the cables must be fastened with bolts.

These figures apply to the following terminals:

Mains terminals **Nos. 91, 92, 93**
L1, L2, L3

Motor terminals **Nos. 96, 97, 98**
U, V, W

Earth terminal **No. 99**

VLT type	Tightening-up torque	Screw size
3 x 200-240 V		
VLT 6002-6005	0.5 - 0.6 Nm	M3
VLT 6006-6011	1.8 Nm	M4
VLT 6016-6027	3.0 Nm	M5
VLT 6032	4.0 Nm	M6

VLT type	Tightening-up torque	Bolt size
3 x 200-240 V		
VLT 6042-6062	11.3 Nm	M8

VLT type	Tightening-up torque	Screw size
3 x 380-460 V		
VLT 6002-6011	0.5 - 0.6 Nm	M3
VLT 6016-6027	1.8 Nm	M4
VLT 6032-6062	3.0 Nm	M5

VLT type	Tightening-up torque	Bolt size
3 x 380-460 V		
VLT 6075-6125	11.3 Nm	M8
VLT 6150-6275	11.3 Nm	M8

■ Mains connection

Mains must be connected to terminals 91, 92, 93.

Nos. 91, 92, 93 Mains voltage 3 x 200-240 V
L1, L2, L3 Mains voltage 3 x 380-460 V



NB!

Check that the mains voltage fits the mains voltage of the VLT frequency converter, which can be seen from the nameplate.

See *Technical data* for correct sizing of cable cross-sections.

■ Pre-fuses

For VLT type 6002-6275, external pre-fuses must be installed in the mains supply to the frequency converter. For UL/cUL applications with a mains voltage of 200-240 V, pre-fuses of type Bussmann KTN-R (200-240 V) or similar must be used. For UL/cUL applications with a mains voltage of 380-460 V, pre-fuses of type Bussmann KTS-R (380-460 V) or similar must be used.

For VLT type 6060-6275 HVAC, 380/460 V and VLT 6032-6052, 200-240 V, pre-fuses are included in the frequency converter mains connection; however, external pre-fuses must also be fitted.

See *Technical data* for correct sizing of pre-fuses.

■ Motor connection

The motor must be connected to terminals 96, 97, 98. Earth to terminal 99.

Nos. 96, 97, 98
U, V, W
No. 99

Motor voltage 0-100% of mains voltage.

Earth connection.

See *Technical data* for correct sizing of cable cross-sections.

All types of three-phase asynchronous standard motors can be used with a VLT 6000 HVAC unit.

Small-size motors are normally star-connected (220/380 V, Δ/Y). Large-size motors are delta-connected (380/660 V, Δ/Y).

The correct connection and voltage can be read from the motor nameplate.



NB!

In older motors without phase coil insulation, a LC filter should be fitted to the VLT frequency converter output. See the Design Guide or contact Danfoss.

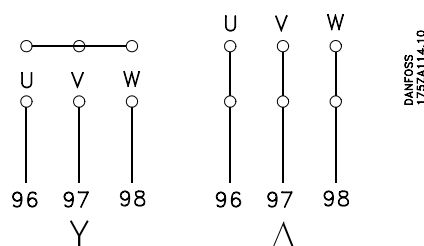

■ Direction of motor rotation

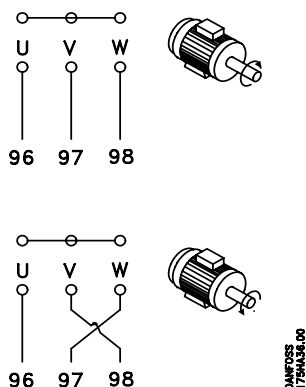

The factory setting is for clockwise rotation with the VLT frequency transformer output connected as follows.

- Terminal 96 connected to U-phase
- Terminal 97 connected to V-phase
- Terminal 98 connected to W-phase

The direction of rotation can be changed by switching two phases in the motor cable.

■ Parallel coupling of motors

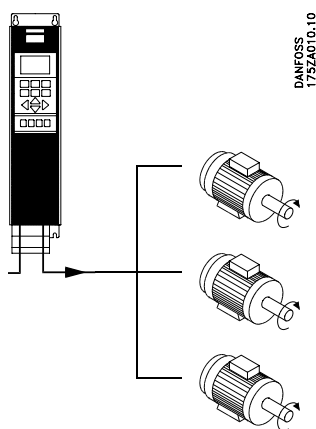

VLT 6000 HVAC is able to control several motors connected in parallel. If the motors are to have different rpm values, the motors must have different rated rpm values. Motor rpm is changed simultaneously, which means that the ratio between the rated rpm values is maintained across the range.

The total current consumption of the motors is not to exceed the maximum rated output current $I_{VLT,N}$ for the VLT frequency converter.

Problems may arise at the start and at low rpm values if the motor sizes are widely different. This is because the relatively high ohmic resistance in small motors calls for a higher voltage at the start and at low rpm values.

In systems with motors connected in parallel, the electronic thermal relay (ETR) of the VLT frequency converter cannot be used as motor protection for the individual motor. Consequently, additional motor protection is required, such as thermistors in each motor (or individual thermal relays).



NB!

Parameter 107 *Automatic Motor Adaptation, AMA* and *Automatic Energy Optimization, AEO* in parameter 101 *Torque characteristics* cannot be used if motors are connected in parallel.

■ Motor cables

See *Technical data* for correct sizing of motor cable cross-section and length.

Always comply with national and local regulations on cable cross-sections.



NB!

If an unscreened/unarmoured cable is used, some EMC requirements are not complied with, see *EMC test results*.

If the EMC specifications regarding emission are to be complied with, the motor cable must be screened/armoured, unless otherwise stated for the RFI filter in question. It is important to keep the motor cable as short as possible so as to reduce the noise level and leakage currents to a minimum.

The motor cable screen must be connected to the metal cabinet of the frequency converter and to the metal cabinet of the motor. The screen connections are to be made with the biggest possible surface (cable clamp). This is enabled by different installation devices in the different VLT frequency converters. Mounting with twisted screen ends (pigtailed) is to be avoided, since these spoil the screening effect at higher frequencies.

If it is necessary to break the screen to install a motor isolator or motor contactor, the screen must be continued at the lowest possible HF impedance.

■ Motor thermal protection

The electronic thermal relay in UL-approved VLT frequency converters has received UL-approval for single motor protection, as long as parameter 117 *Motor thermal protection* has been set to ETR Trip and parameter 105 *Motor current, I_{VLT,N}* has been programmed for the rated motor current (can be read from the motor nameplate).

■ Earth connection

Since the leakage currents to earth may be higher than 3.5 mA, the VLT frequency converter must always be earthed in accordance with applicable national and local regulations. In order to ensure good mechanical connection of the earth cable, its cable cross-section must be at least 10 mm². For added security, an RCD (Residual Current Device) may be installed. This ensures that the VLT frequency converter will cut out if the leakage currents get too high. See RCD instructions MI.66.AX.02.

■ DC bus connection

The DC bus terminal is used for DC back-up, with the intermediate circuit being supplied from an external DC source. In addition, a 12-pulse option can be connected to reduce the total harmonic distortion.

Terminal nos. **Nos. 88, 89**

Contact Danfoss and ask for the Design Guide if you require further information.

■ High-voltage relay

The cable for the high-voltage relay must be connected to terminals 01, 02, 03. The high-voltage relay is programmed in parameter 323, *Relay 1, output*.

No. 1	Relay output 1 1+3 break, 1+2 make. Max. 240 V AC, 2 Amp. Min. 24 V DC, 10 mA or 24 V AC, 100 mA.
--------------	---

Max. cross-section: 4 mm²/10 AWG.

Torque: 0.5 - 0.6 Nm.

Screw size: M3.

■ Control card

All terminals for the control cables are located under the protective cover of the VLT frequency converter. The protective cover (see drawing below) can be removed by means of a pointed object - a screwdriver or similar.

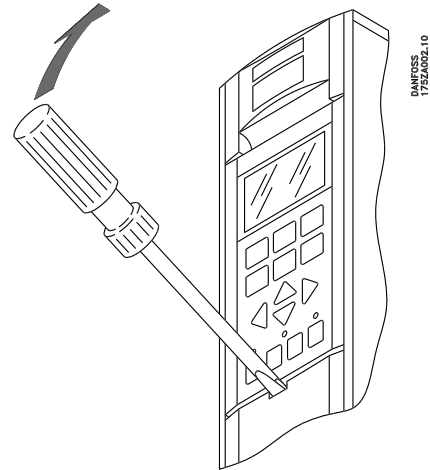

■ Electrical installation, control cables

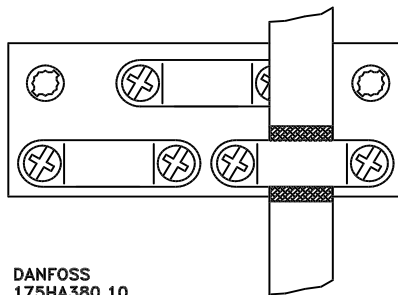

Torque: 0.5 - 0.6 Nm.
Screw size: M3.

Generally speaking, control cables must be screened/ armoured and the screen must be connected by means of a cable clamp at both ends to the metal cabinet of the unit (see instructions for installation page 57).

Normally, the screen must also be connected to the body of the controlling unit (follow the instructions for installation given for the unit in question).

If very long control cables are used, 50/60 Hz earth loops may occur that will disturb the whole system. This problem can be solved by connecting one end of the screen to earth via a 100nF condenser (keeping leads short).

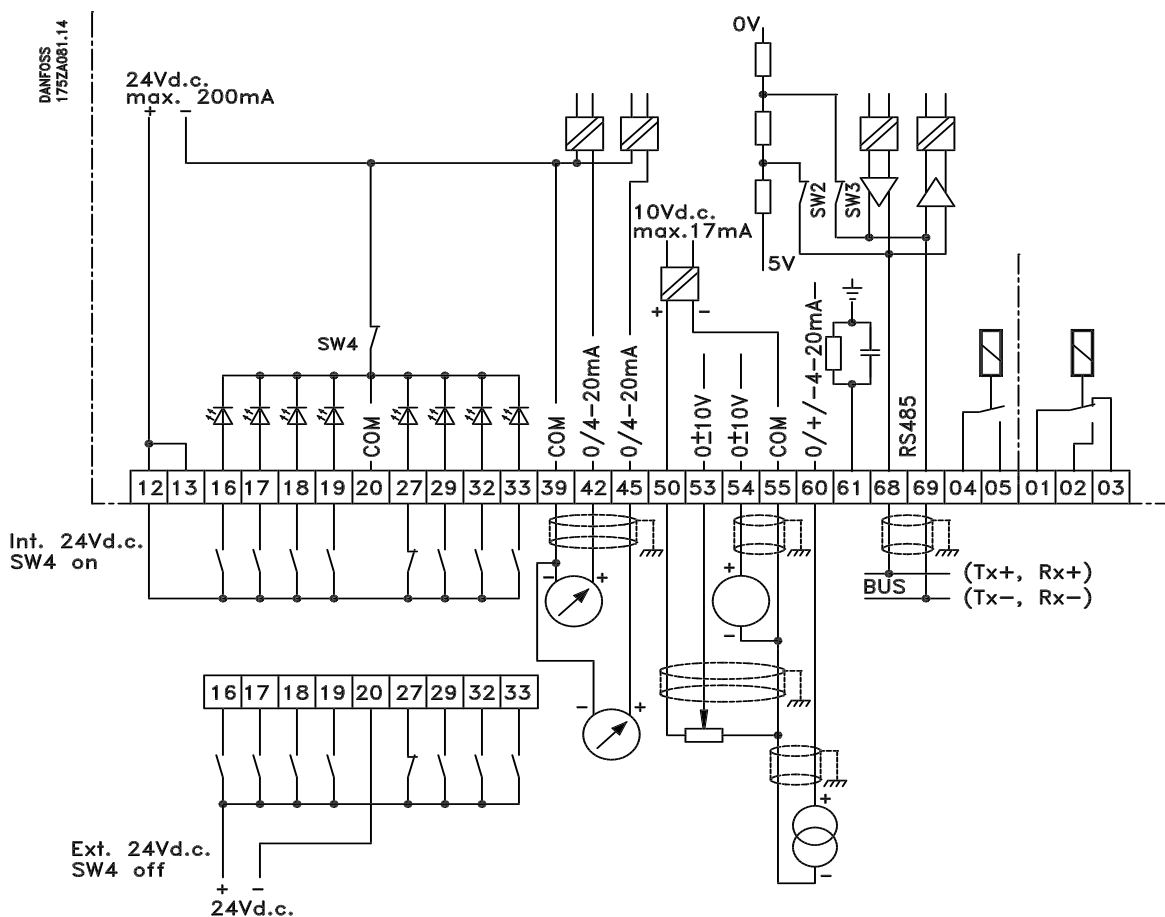

■ Connection example, VLT 6000 HVAC

The diagram below gives an example of a typical VLT 6000 HVAC installation.

The mains supply is connected to terminals 91 (L1), 92 (L2) and 93 (L3), while the motor is connected to 96 (U), 97 (V) and 98 (W). These numbers can also be seen from the terminals of the VLT frequency converter.

An external DC supply or a 12-pulse option can be connected to terminals 88 and 89. Please ask Danfoss for a Design Guide to learn more.

Analogue inputs can be connected to terminals 53 [V], 54 [V] and 60 [mA]. These inputs can be programmed for either reference, feedback or thermistor. See *Analogue inputs* in parameter group 300.

There are 8 digital inputs, which can be connected to terminals 16-19, 27, 29, 32, 33. These inputs can be programmed in accordance with the table on page 69.

There are two analogue/digital outputs (terminals 42 and 45), which can be programmed to show the present status or a process value, such as $0-f_{MAX}$. Relay outputs 1 and 2 can be used for giving the present status or a warning.

On terminals 68 (P+) and 69 (N-) RS 485 interface, the VLT frequency converter can be controlled and monitored via serial communication.

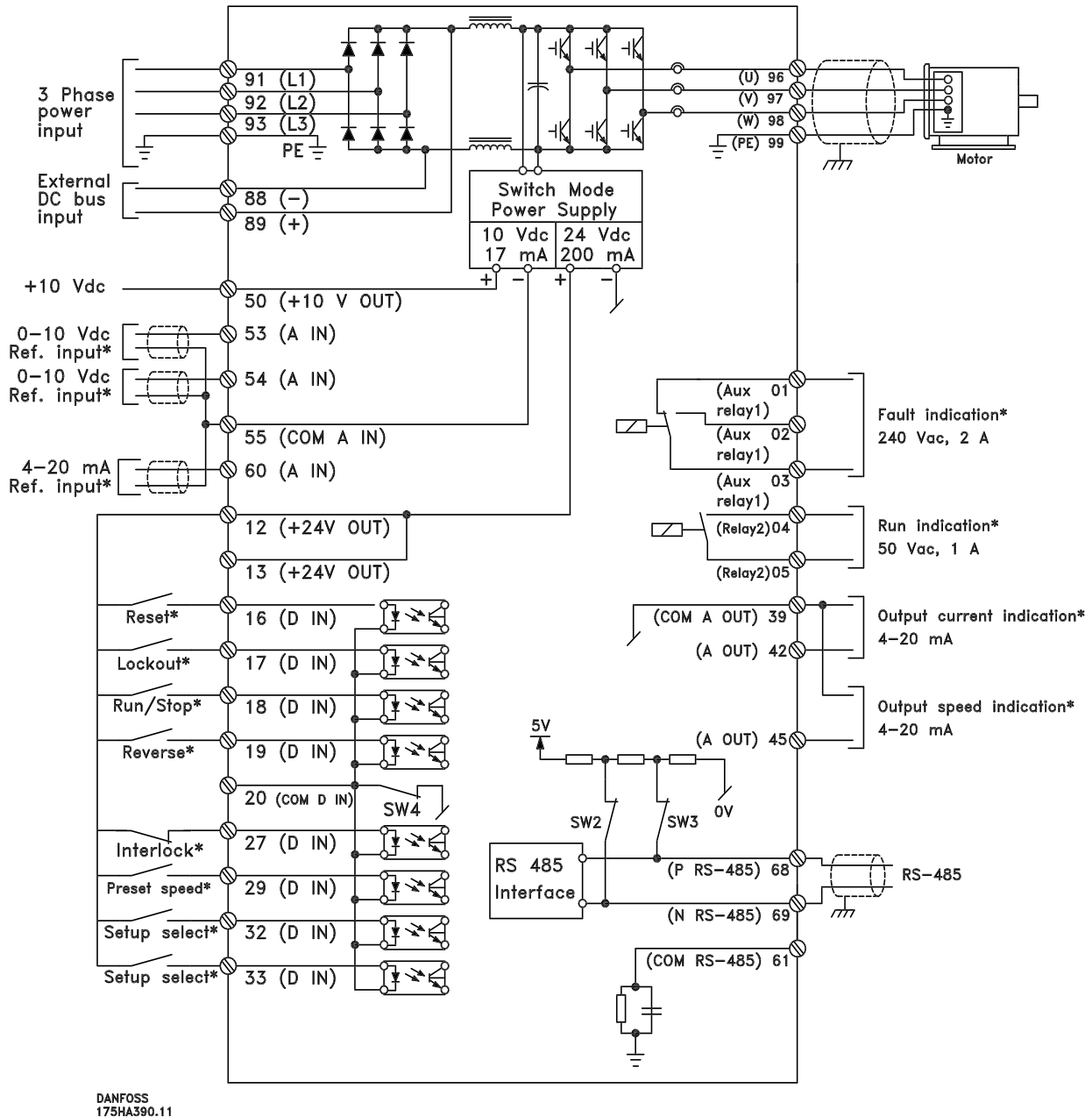

* These terminals can be programmed for other functions.

Electrical installation, control cables

Torque: 0.5-0.6 Nm

Screw size: M3

See page 56 for correct termination of control cables.

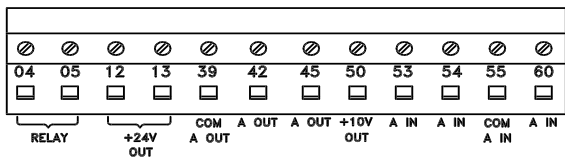
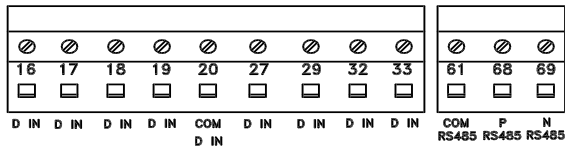
 DANFOSS
175HA379.10

No.	Function
04, 05	Relay output 1 can be used for indicating status and warnings.
12, 13	Voltage supply to digital inputs. For the 24 V DC to be used for digital inputs, switch 4 on the control card must be closed, position "on".
16-33	Digital inputs. See parameters 300-307 <i>Digital inputs</i> .
20	Common for digital inputs.
39	Common for analogue/digital outputs. Must be connected to terminal 55 by means of a three-wire transmitter. See <i>Examples of connection</i> .
42, 45	Analogue/digital outputs for indicating frequency, reference, current and torque. See parameters 319-322 <i>Analogue/digital outputs</i> .
50	Supply voltage to potentiometer and thermistor 10 V DC.
53, 54	Analogue voltage input, 0 - 10 V DC.
55	Common for analogue voltage inputs.

No.	Function
60	Analogue current input 0/4-20 mA. See parameters 314-316 <i>Terminal 60</i> .
61	Termination of serial communication. See page 56. This terminal is not normally to be used.
68, 69	RS 485 interface, serial communication. Where the VLT frequency converter is connected to a bus, switches 2 and 3 (switches 1- 4 - see next page) must be closed on the first and the last VLT frequency converter. On the remaining VLT frequency converters, switches 2 and 3 must be open. The factory setting is closed (position on).

Switches 1-4

The dipswitch is located on the control card.

It is used for serial communication and external DC supply.

The switching position shown is the factory setting.

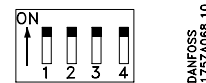

Switch 1 has no function.

Switches 2 and 3 are used for terminating an RS 485 interface, serial communication. In the first and the last VLT frequency converter, switches 2 and 3 must be ON. In the other VLT frequency converters, switches 2 and 3 must be OFF.

Switch 4 is used if an external 24 V DC supply is required for the control terminals.

Switch 4 separates the common potential for the internal 24 V DC supply from the common potential of the external 24 V DC supply.

NB!

Please note that when Switch 4 is in position "OFF", the external 24 V DC supply is galvanically isolated from the VLT frequency converter.

■ Connection examples Single-pole start/stop

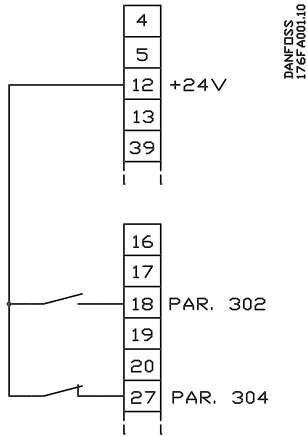

- Start/stop using terminal 18.
Parameter 302 = *Start* [1]
- Quick-stop using terminal 27.
Parameter 304 = *Coasting stop, inverse* [0]

Digital speed up/down

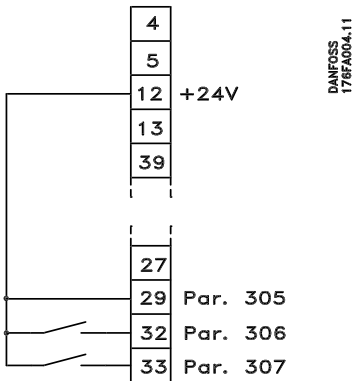

- Speed up and down using terminals 32 and 33.
Parameter 306 = *Speed up* [7]
Parameter 307 = *Speed down* [7]
Parameter 305 = *Freeze reference* [2]

Potentiometer reference

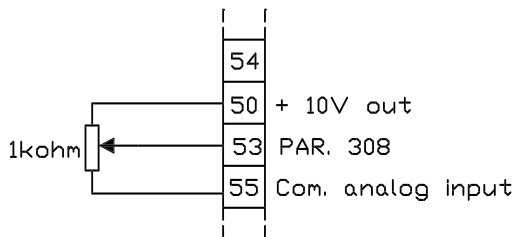

- Parameter 308 = *Reference* [1]
Parameter 309 = *Terminal 53, min. scaling*
Parameter 310 = *Terminal 53, max. scaling*

Run permissive

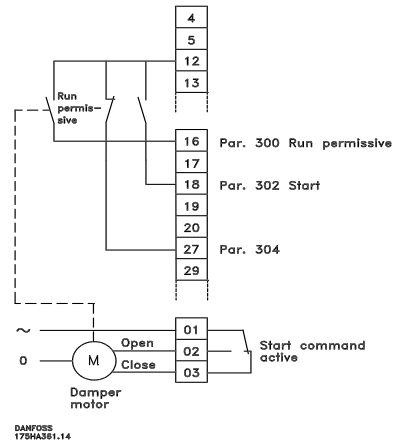

- Start permitted with terminal 16.
Parameter 300 = *Start enabled* [8].
- Start/stop with terminal 18.
Parameter 302 = *Start* [1].
- Quickstop with terminal 27.
Parameter 304 = *Coasting stop, inverse* [0].
- Activated damper (motor)
Parameter 323 = *Start command active* [13].

2-zone regulation

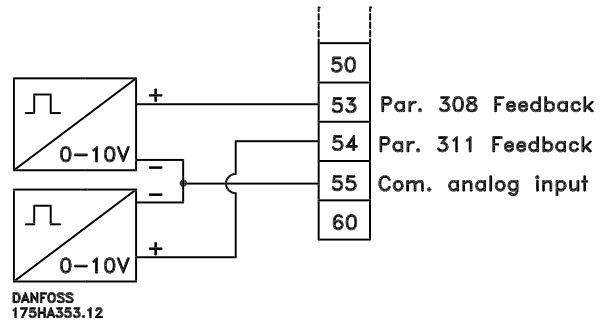

- Parameter 308 = *Feedback* [2].
- Parameter 311 = *Feedback* [2].

Transmitter connection

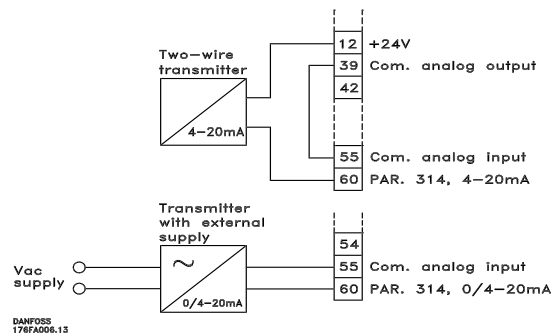

- Parameter 314 = *Reference* [1]
- Parameter 315 = *Terminal 60, min. scaling*
- Parameter 316 = *Terminal 60, max. scaling*

■ **Control unit LCP**

The front of the VLT frequency converter features a control panel - LCP (Local Control Panel). This is a complete interface for operation and programming of the VLT 6000 HVAC.

The control panel is detachable and can - as an alternative - be installed up to 3 metres away from the VLT frequency converter, e.g. on the front panel, by means of a mounting kit option.

The functions of the control panel can be divided into five groups:

1. Display
2. Keys for changing display mode
3. Keys for changing program parameters
4. Indicator lamps
5. Keys for local operation.

All data are indicated by means of a 4-line alpha-numeric display, which, in normal operation, is able to show 4 operating data values and 3 operating condition values continuously. During programming, all the information required for quick, effective parameter Setup of the VLT frequency converter will be displayed. As a supplement to the display, there are three indicator lamps for voltage (ON), warning (WARNING) and alarm (ALARM), respectively.

All VLT frequency converter parameter Setups can be changed immediately via the control panel, unless this function has been programmed to be *Locked* [1] via parameter 016 *Lock for data change* or via a digital input, parameters 300-307 *Lock for data change*.

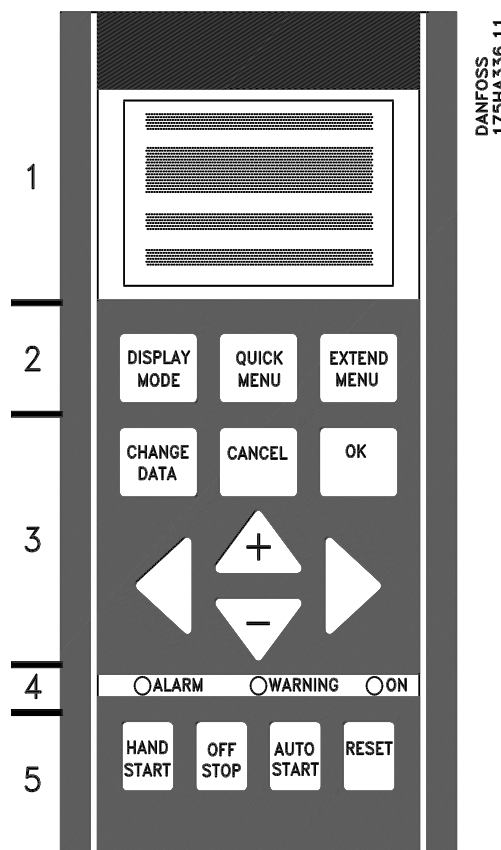

■ **Control keys for parameter Setup**

The control keys are divided into functions. This means that the keys between display and indicator lamps are used for parameter Setup, including selecting the display indication during normal operation.

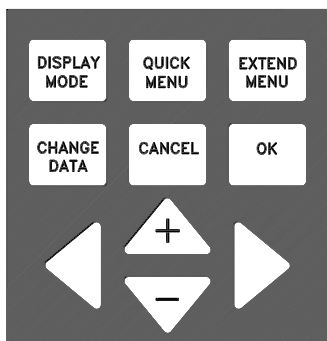

DISPLAY MODE [DISPLAY / STATUS] is used for selecting the indication mode of the display or when returning to the Display mode from either the Quick menu or the Extend menu mode.

QUICK MENU [QUICK MENU] gives access to the parameters used for the Quick menu. It is possible to switch between the Quick menu and the Extend menu modes.

EXTEND MENU [EXTEND MENU] gives access to all parameters. It is possible to switch between the Extend menu and the Quick menu modes.

CHANGE DATA [CHANGE DATA] is used for changing a setting selected either in the Extend menu or the Quick menu mode.

CANCEL [CANCEL] is used if a change of the selected parameter is not to be carried out.

OK [OK] is used for confirming a change of the parameter selected.

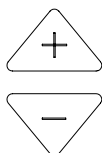

[+/-] is used for selecting parameters and for changing a chosen parameter. These keys are also used to change the local reference. In addition, the keys are used in Display mode to switch between operation variable readouts.

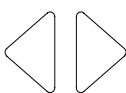

[<>] is used when selecting a parameter group and for moving the cursor when changing numerical values.

Indicator lamps

At the bottom of the control panel is a red alarm lamp and a yellow warning lamp, as well as a green voltage LED.

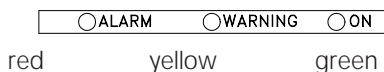

If certain threshold values are exceeded, the alarm and/or warning lamp is activated, and a status or alarm text is displayed.



NB!

The voltage indicator lamp is activated when the VLT frequency converter receives voltage.

Local control

Underneath the indicator lamps are keys for local control.

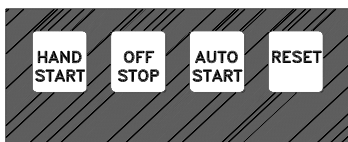

[HAND START] is used if the VLT frequency converter is to be controlled via the control unit. The VLT frequency converter will start the motor, since a start command is given by means of [HAND START].

On the control terminals, the following control signals will still be active when [HAND START] is activated:

- Hand start - Off stop - Auto start
- Safety Interlock
- Reset
- Coasting stop inverse
- Reversing
- Setup select lsb - Setup select msb
- Jog
- Run permissive
- Lock for data change
- Stop command from serial communication



NB!

If parameter 201 *Output frequency low limit* f_{MIN} is set to an output frequency greater than 0 Hz, the motor will start and ramp up to this frequency when [HAND START] is activated.



[OFF/STOP] is used for stopping the connected motor. Can be selected as Enable [1] or Disable [0] via parameter 013. If the stop function is activated, line 2 will flash.



[AUTO START] is used if the VLT frequency converter is to be controlled via the control terminals and/or serial communication. When a start signal is active on the control terminals and/or the bus, the VLT frequency converter will start.



NB!

An active HAND-OFF-AUTO signal via the digital inputs will have higher priority than the control keys [HAND START]-[AUTO START].



[RESET] is used for resetting the VLT frequency converter after an alarm (trip). Can be selected as *Enable* [1] or *Disable* [0] via parameter 015 *Reset on LCP*.

Display mode

In normal operation, any 4 different operating variables can be indicated continuously: 1.1 and 1.2 and 1.3 and 2. The present operating status or alarms and warnings that have arisen are shown in line 2 in the form of a number. In the case of alarms, the alarm in question will be shown in lines 3 and 4, accompanied by an explanatory note. Warnings will flash in line 2, with an explanatory note in line 1. In addition, the display shows the active Setup.

The arrow indicates the direction of rotation; here the VLT frequency converter has an active reversing signal. The arrow body disappears if a stop command is given or if the output frequency falls below 0.01 Hz. The bottom line gives the status of the VLT frequency converter. See next page.

The scroll list on the next page gives the operating data that can be shown for variable 2 in display mode. Changes are made via the [+/-] keys.

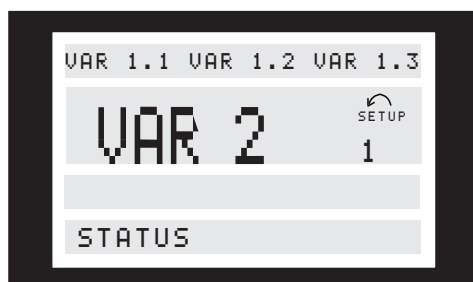

■ Display mode, cont.

The table below gives the operating data options for the first and second line of the display.

Scroll-list:	Unit:
Resulting reference, %	[%]
Resulting reference, unit	[unit]
Frequency	[Hz]
% of maximum output frequency	[%]
Motor current	[A]
Power	[kW]
Power	[HP]
Output energy	[kWh]
Hours run	[hours]
Used-defined readout	[unit]
Setpoint 1	[unit]
Setpoint 2	[unit]
Feedback 1	[unit]
Feedback 2	[unit]
Feedback	[unit]
Motor voltage	[V]
DC-link voltage	[V]
Thermal load on motor	[%]
Thermal load on VLT	[%]
Input status, dig. input	[binary code]
Input status, analogue terminal 53	[V]
Input status, analogue terminal 54	[V]
Input status, analogue terminal 60	[mA]
Pulse reference	[Hz]
External reference	[%]
Heat sink temperature	[°C]
User-defined text	[-]

Three operating data values can be shown in the first display line, while one operating variable can be shown in the second display line. To be programmed via parameters 007, 008, 009 and 010 *Display readout*.

■ Display mode I:

VLT 6000 HVAC offers different display modes depending on the mode selected for the VLT frequency converter. The figure on the next page shows the way to navigate between different display modes.

Below is a display mode, in which the VLT frequency converter is in Auto mode with remote reference at an output frequency of 40 Hz.

In this display mode, reference and control are determined via the control terminals.

The text in line 1 gives the operating variable shown in line 2.

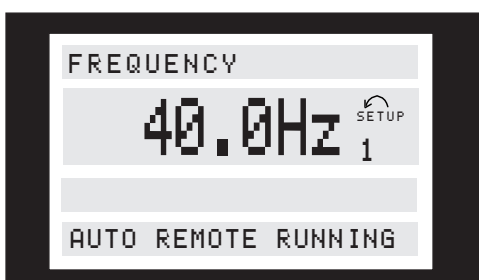

Line 2 gives the current output frequency and the active Setup.

Line 4 says that the VLT frequency converter is in Auto mode with remote reference, and that the motor is running.

• Status line:

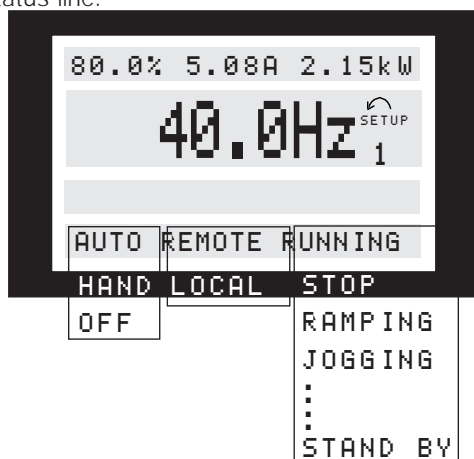

The left part of the status line indicates the control element of the VLT frequency converter that is active. AUTO means that control is via the control terminals, while HAND indicates that control is via the local keys on the control unit.

OFF means that the VLT frequency converter ignores all control commands and stops the motor.

The centre part of the status line indicates the reference element that is active. REMOTE means that the reference from the control terminals is active, while LOCAL indicates that the reference is determined via the [+/-] keys on the control panel.

The last part of the status line indicates the current status, for example "Running", "Stop" or "Alarm".

■ Display mode II:

This display mode makes it possible to have three operating data values displayed at the same time in line 1.

The operating data values are determined in parameters 007-010 *Display readout*.

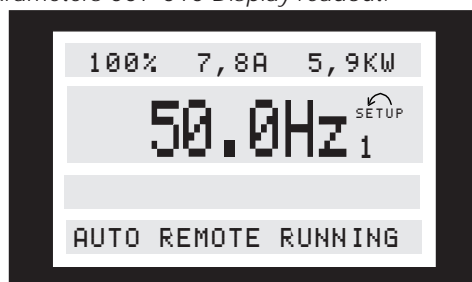

■ Display mode III:

This display mode can be generated as long as the [DISPLAY MODE] key is kept depressed. In the first line, operating data names and units of operating data are displayed. In the second line, operating data 2 remains unchanged. When the key is released, the different operating data values are shown.

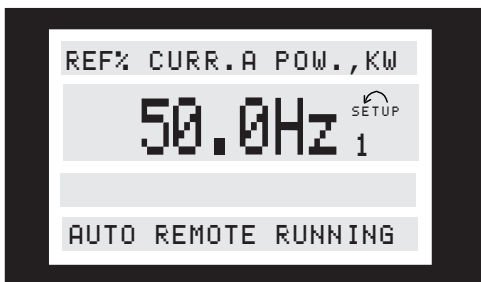

■ Display mode IV:

This display mode is only generated in connection with local reference, see also reference handling on page 60. In this display mode, the reference is determined via the [+/-] keys and control is carried out by means of the keys underneath the indicator lamps.

The first line indicates the required reference. The third line gives the relative value of the present output frequency at any given time in relation to the maximum frequency. The display is in the form of a bar graph.

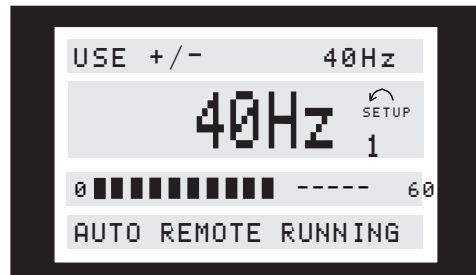

■ Navigation between display modes

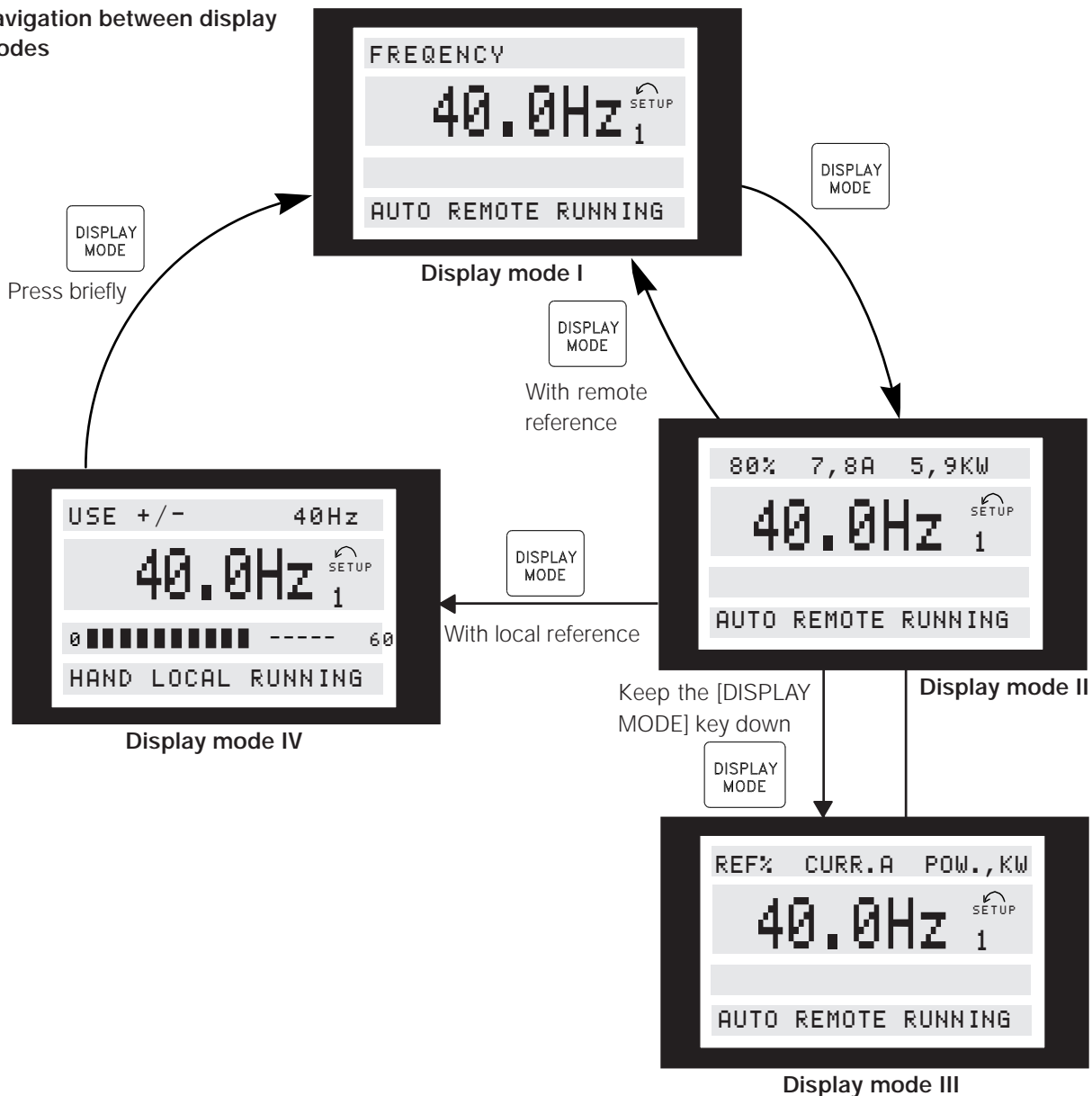

■ Changing data

Regardless of whether a parameter has been selected under the Quick menu or the Extend menu, the procedure for changing data is the same.

Pressing the [CHANGE DATA] key gives access to changing the selected parameter, following which the underlining in line 4 will flash on the display.

The procedure for changing data depends on whether the selected parameter represents a numerical data value or a functional value.

If the chosen parameter represents a numeric data value, the first digit can be changed by means of the [+/-] keys. If the second digit is to be changed, first move the cursor by using the [<>] keys, then change the data value using the [+/-] keys.

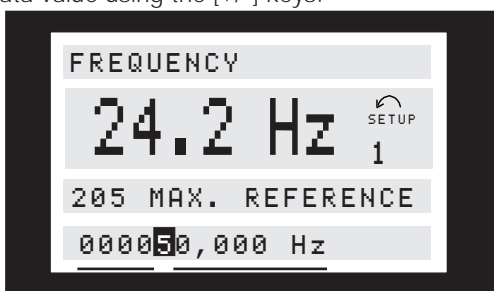

The selected digit is indicated by a flashing cursor. The bottom display line gives the data value that will be entered (saved) when signing off by pressing the [OK] button. Use [CANCEL] to cancel the change.

If the selected parameter is a functional value, the selected text value can be changed by means of the [+/-] keys.

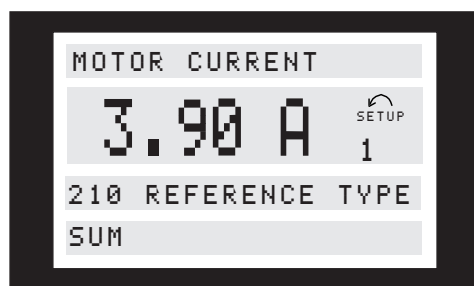

The functional value flashes until signing off by pressing the [OK] button. The functional value has now been selected. Use [CANCEL] to cancel the change.

■ Infinitely variable change of numeric data value

If the chosen parameter represents a numeric data value, a digit is first selected by means of the [<>] keys.

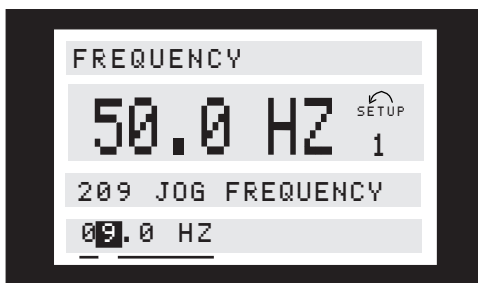

Then the chosen digit is changed infinitely variably by means of the [+/-] keys:

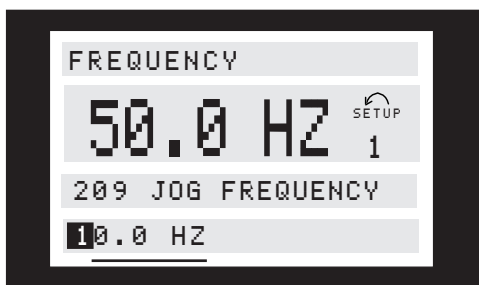

The chosen digit is indicated by the digit flashing. The bottom display line shows the data value that will be entered (saved) when signing off with [OK].

■ Changing of data value, step-by-step

Certain parameters can be changed both step by step and infinitely variably. This applies to *Motor power* (parameter 102), *Motor voltage* (parameter 103) and *Motor frequency* (parameter 104).

This means that the parameters are changed both as a group of numeric data values and as numeric data values infinitely variably.

■ Manual initialisation

Disconnect from mains and hold the [DISPLAY/STATUS] + [CHANGE DATA] + [OK] keys down while at the same time reconnecting the mains supply. Release the keys: the VLT frequency converter has now been programmed for the factory setting.

The following parameters are not zeroed by means of manual initialisation:

- parameter 500, Protocol
- 600, *Operating hours*
- 601, *Hours run*
- 602, *kWh counter*
- 603, *Number of power-ups*
- 604, *Number of overtemperatures*
- 605, *Number of overvoltages*

It is also possible to carry out initialisation via parameter 620 *Operating mode*, see page 145 regarding procedure.

■ Quick menu

The [QUICK MENU] key gives access to the 12 most important parameters of the VLT frequency converter. After programming, the VLT frequency converter will in most cases be ready for operation. Scroll through the Quick menu using the [+/-] keys and change the data values by pushing [CHANGE DATA] + [OK].

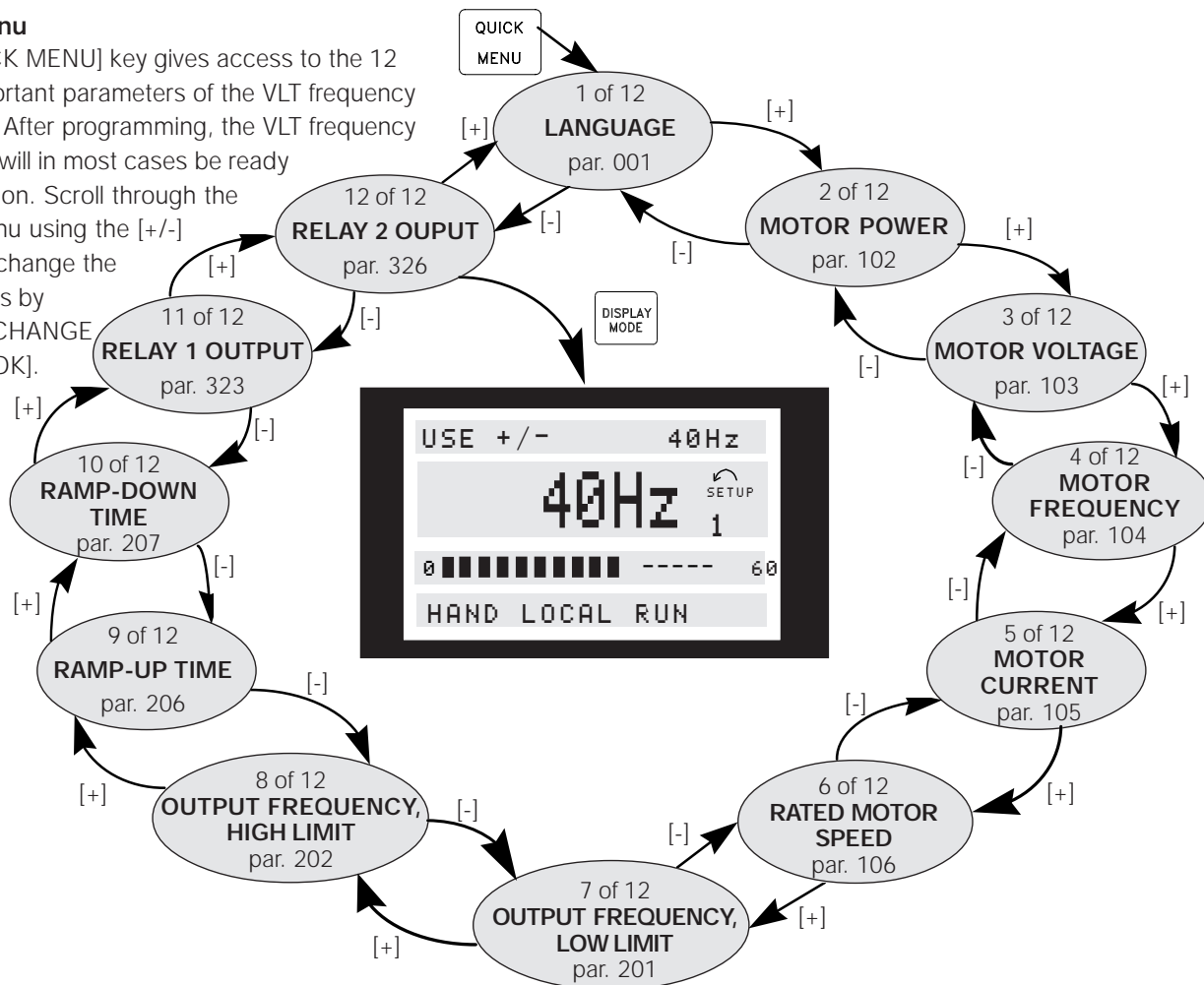

Quick menu: Parameter 1 of 12
Used to select the language for the display.

Quick menu: Parameter 2 of 12
Select the kW value that equals the rated motor value $P_{M,N}$. There is a choice of four undersizes or one oversize in relation to the factory setting.

Quick menu: Parameter 3 of 12
Used to set the rated motor voltage $U_{M,N}$ while taking into consideration whether the motor is star or delta connected.

Quick menu: Parameter 4 of 12
Used to select the rated motor frequency $f_{M,N}$.

Quick menu: Parameter 5 of 12
Used to select motor current $I_{M,N}$ while taking into consideration whether the motor is star or delta connected.

Quick menu: Parameter 6 of 12
Used to select the value that corresponds to the rated motor speed $n_{M,N}$ that can be seen from the nameplate data.

Quick menu: Parameter 7 of 12
Used to select a minimum frequency limit, corresponding to the lowest frequency at which the motor is to run.

Quick menu: Parameter 8 of 12
Used to select a maximum frequency limit, corresponding to the highest frequency at which the motor is to run.

Quick menu: Parameter 9 of 12
The ramp-up time is the acceleration time from 0 Hz to the rated motor frequency $f_{M,N}$ (parameter 104).

Quick menu: Parameter 10 of 12
The ramp-down time is the deceleration time from the rated motor frequency $f_{M,N}$ (parameter 104) to 0 Hz.

Quick menu: Parameter 11 of 12
Relay output 1 can be used for indicating status and warnings. The relay is activated when the conditions for the relevant data values have been fulfilled.

Quick menu: Parameter 12 of 12
Relay output 2 can be used for indicating status and warnings. The relay is activated when the conditions for the relevant data values have been fulfilled.

■ Programming



Using the [EXTEND MENU] key, it is possible to have access to all the parameters for the VLT frequency converter.

■ Operation and Display 000-017

This parameter group makes it possible to set up the control unit, e.g. with respect to language, display readout and the possibility of making the function keys on the control unit inactive.

001 Language (LANGUAGE)

Value:

★ English (ENGLISH)	[0]
German (DEUTSCH)	[1]
French (FRANCAIS)	[2]
Danish (DANSK)	[3]
Spanish (ESPAÑOL)	[4]
Italian (ITALIANO)	[5]
Swedish (SVENSKA)	[6]
Dutch (NEDERLANDS)	[7]
Portuguese (PORTUGUESA)	[8]

State when delivered may vary from factory setting.

Function:

The choice in this parameter defines the language to be used on the display.

Description of choice:

There is a choice of the languages indicated.

■ The Setup configuration

VLT 6000 HVAC has four Setups (parameter Setups) that can be programmed independently of each other. The active Setup can be selected in parameter 002 *Active Setup*. The active Setup number will be shown in the display under "Setup".

It is also possible to set the VLT frequency converter to *Multi-Setup* to allow switching of Setups with the digital inputs or serial communication.

Setup shifts can be used in systems where, e.g., one Setup is used during the day and another at night.

Parameter 003 *Copying of Setups* enables copying from one Setup to another.

By means of parameter 004 *LCP copy*, all Setups can be transferred from one VLT frequency converter to another by moving the control panel. First all parameter values are copied to the control panel. This can then be moved to another VLT frequency converter, where all parameter values can be copied from the control unit to the VLT frequency converter.

002 Active Setup (ACTIVE SETUP)

Value:

Factory Setup (FACTORY SETUP)	[0]
★ Setup 1 (SETUP 1)	[1]
Setup 2 (SETUP 2)	[2]
Setup 3 (SETUP 3)	[3]
Setup 4 (SETUP 4)	[4]
MultiSetup (MULTI SETUP)	[5]

Function:

The choice in this parameter defines the Setup number you want to control the functions of the VLT frequency converter.

All parameters can be programmed in four individual parameter Setups, Setup 1 - Setup 4.

In addition, a pre-programmed Setup called the Factory Setup exists. This only allows specific parameters to be changed.

Description of choice:

Factory Setup [0] contains the parameter values preset at the factory. Can be used as a data source if the other Setups are to be returned to a known state. In this case Factory Setup is selected as the active Setup.

Setups 1-4 [1]-[4] are four individual Setups that can be selected as required.

MultiSetup [5] is used if remote switching between different Setups is required. Terminals 16/17/29/32/33 and the serial communication port can be used for switching between Setups.

★ = factory setting. () = display text [] = value for use in communication via serial communication port

Connection examples

Setup change

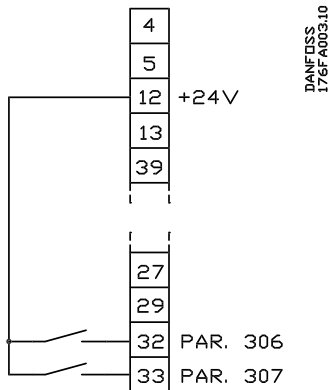

- Selection of Setup using terminals 32 and 33.
 Parameter 306 = *Selection of Setup, lsb* [4]
 Parameter 307 = *Selection of Setup, msb* [4]
 Parameter 004 = *MultiSetup* [5].

003 Copying of Setups (SETUP COPY)

Value:	
★ No copying (NO COPY)	[0]
Copy active Setup to Setup 1 (COPY TO SETUP 1)	[1]
Copy active Setup to Setup 2 (COPY TO SETUP 2)	[2]
Copy active Setup to Setup 3 (COPY TO SETUP 3)	[3]
Copy active Setup to Setup 4 (COPY TO SETUP 4)	[4]
Copy active Setup to all (COPY TO ALL)	[5]

Function:

A copy is made from the active Setup selected in parameter 002 Active Setup to the Setup or Setups selected in parameter 003 Copying of Setups.

NB! Copying is only possible in Stop mode (motor stopped on a Stop command).

Description of choice:

The copying starts when the required copying function has been selected and the [OK] key has been pressed.
 The display indicates when copying is in progress.

004 LCP copy (LCP COPY)

Value:	
★ No copying (NO COPY)	[0]
Upload all parameters (UPLOAD ALL PARAMET.)	[1]
Download all parameters (DOWNLOAD ALL PARAM.)	[2]
Download power-independent par. (DOWNLOAD SIZE INDEP.)	[3]

Function:

Parameter 004 *LCP copy* is used if the integrated copying function of the control panel is to be used. This function is used if all parameter Setups are to be copied from one VLT frequency converter to another by moving the control panel.

Description of choice:

Select *Upload all parameters* [1] if all parameter values are to be transmitted to the control panel.
 Select *Download all parameters* [2] if all transmitted parameter values are to be copied to the VLT frequency converter on which the control panel has been mounted.
 Select *Download power-independent par.* [3] if only the power-independent parameters are to be downloaded. This is used if downloading to a VLT frequency converter that has a different rated power than the one from where the parameter Setup originates.

NB! Uploading/Downloading can only be carried out in the Stop mode.

Setup of user-defined readout

Parameter 005 *Max. value of user-defined readout* and 006 *Unit for user-defined readout* allow users to design their own readout which can be seen if user-defined readout has been selected under display readout. The range is set in parameter 005 *Max. value of user-defined readout* and the unit is determined in parameter 006 *Unit for user-defined readout*. The choice of unit decides whether the ratio between the output frequency and the readout is a linear, square or cubed ratio.

★ = factory setting. () = display text [] = value for use in communication via serial communication port

005 Max. value of user-defined readout (CUSTOM READOUT)

Value:

0.01 - 999,999.99 ★100.00

Function:

This parameter allows a choice of the max. value of the user-defined readout. The value is calculated on the basis of the present motor frequency and the unit selected in parameter 006 *Unit for user-defined readout*. The programmed value is reached when the output frequency in parameter 202 *Output frequency high limit, f_{MAX}* is reached. The unit also decides whether the ratio between output frequency and readout is linear, square or cubed.

Description of choice:

Set the required value for max. output frequency.

006 Unit for user-defined readout (CUST. READ. UNIT)

Value:

★ No unit ¹	[0]	GPM ¹	[21]
% ¹	[1]	gal/s ¹	[22]
rpm ¹	[2]	gal/min ¹	[23]
ppm ¹	[3]	gal/h ¹	[24]
pulse/s ¹	[4]	lb/s ¹	[25]
l/s ¹	[5]	lb/min ¹	[26]
l/min ¹	[6]	lb/h ¹	[27]
l/h ¹	[7]	CFM ¹	[28]
kg/s ¹	[8]	ft ³ /s ¹	[29]
kg/min ¹	[9]	ft ³ /min ¹	[30]
kg/h ¹	[10]	ft ³ /h ¹	[31]
m ³ /s ¹	[11]	ft ³ /min ¹	[32]
m ³ /min ¹	[12]	ft/s ¹	[33]
m ³ /h ¹	[13]	in wg ²	[34]
m/s ¹	[14]	ft wg ²	[35]
mbar ²	[15]	PSI ²	[36]
bar ²	[16]	lb/in ²	[37]
Pa ²	[17]	HP ³	[38]
kPa ²	[18]		
MWG ²	[19]		
kW ³	[20]		

Flow and speed units are marked with 1. Pressure units with 2, and power units with 3. See figure in next column.

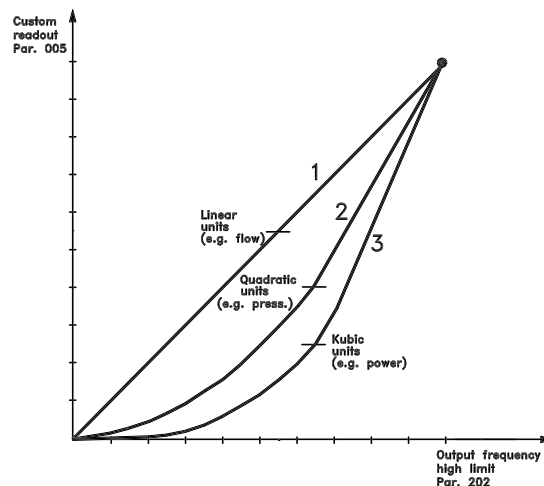

Function:

Select a unit to be shown in the display in connection with parameter 005 *Max. value of user-defined readout*.

If units such as flow or speed units are selected, the ratio between readout and output frequency will be a linear one.

If pressure units are selected (bar, Pa, MWG, PSI, etc.), the ratio will be square.

If power units (kW, HP) are selected, the ratio will be cubed.

The value and the unit are shown in display mode whenever *User-defined readout* [10] has been selected in one of parameters 007-010 *Display readout*.

Description of choice:

Select the required unit for *User-defined readout*.

007 Large display readout (LARGE READOUT)

Value:

Resulting reference [%] (REFERENCE [%])	[1]
Resulting reference [unit] (REFERENCE [UNIT])	[2]
★ Frequency [Hz] (FREQUENCY [HZ])	[3]
% of maximum output frequency [%] (FREQUENCY [%])	[4]
Motor current [A] (MOTOR CURRENT [A])	[5]
Power [kW] (POWER [KW])	[6]
Power [HP] (POWER [HP])	[7]
Output energy [kWh] (ENERGI [UNIT])	[8]
Hours run [Hours] (HOURS RUN [h])	[9]
User-defined readout [-] (CUSTOM READ.[UNITS])	[10]

★ = factory setting. () = display text [] = value for use in communication via serial communication port

Setpoint 1 [unit] (SETPOINT 1 [UNITS])	[11]
Setpoint 2 [unit] (SETPOINT 2 [UNITS])	[12]
Feedback 1 (FEEDBACK 1 [UNITS])	[13]
Feedback 2 (FEEDBACK 2 [UNITS])	[14]
Feedback [unit] (FEEDBACK [UNITS])	[15]
Motor voltage [V] (MOTOR VOLTAGE [V])	[16]
DC link voltage [V] (DC VOLTAGE [V])	[17]
Thermal load, motor [%] (THERM.MOTOR LOAD [%])	[18]
Thermal load, VLT [%] (THERM.DRIVE LOAD [%])	[19]
Digital input [Binary code] (DIGITAL INPUT [BIN])	[20]
Analogue input 53 [V] (ANALOG INPUT 53 [V])	[21]
Analogue input 54 [V] (ANALOG INPUT 54 [V])	[22]
Analogue input 60 [mA] (ANALOG INPUT 53 [mA])	[23]
Pulse reference [Hz] (PULSE REFERENCE [HZ])	[24]
External reference [%] (EXT. REFERENCE [%])	[25]
Heat sink temp. [°C] (HEATSINK TEMP [°C])	[26]
LCP Display text (FREE PROG.ARRAY)	[27]

Function:

This parameter allows a choice of the data value to be shown in the display, line 2, when the VLT frequency converter is turned on. The data values will also be included in the display mode scroll-list. Parameters 008-010 *Small display readout* allow a choice of another three data values, shown in line 1. See the description of the control unit on page 69.

Description of choice:

No readout can only be selected in parameters 008-010 *Small display readout*.

Resulting reference [%] gives a percentage for the resulting reference in the range from *Minimum reference*, Ref_{MIN} to *Maximum reference*, Ref_{MAX} . See also reference handling, page 89.

Reference [unit] gives the resulting reference in Hz in *Open loop*. In *Closed loop*, the reference unit is selected in parameter 415 *Process units*.

Frequency [Hz] gives the output frequency from the VLT frequency converter.

% of maximum output frequency [%] is the present output frequency as a percentage value of parameter 202 *Output frequency high limit*, f_{MAX} .

Motor current [A] states the phase current of the motor measured as effective value.

Power [kW] states the actual power consumed by the motor in kW.

Power [HP] states the actual power consumed by the motor in HP.

Output energy [kWh] states the energy consumed by the motor since the latest reset was made in parameter 618 *Reset of kWh counter*.

Hours run [Hours] states the number of hours that the motor has run since the latest reset in parameter 619 *Reset of hours-run counter*.

User-defined readout [-] is a user-defined value, calculated on the basis of the present output frequency and unit, as well as the scaling in parameter 005 *Max. value of user-defined readout*. Select unit in parameter 006 *Unit for user-defined readout*.

Setpoint 1 [unit] is the programmed setpoint value in parameter 418 *Setpoint 1*. The unit is decided in parameter 415 *Process units*. See also *Feedback handling* on page 115.

Setpoint 2 [unit] is the programmed setpoint value in parameter 419 *Setpoint 2*. The unit is decided in parameter 415 *Process units*.

Feedback 1 [unit] gives the signal value of the resulting feedback 1 (Term. 53). The unit is decided in parameter 415 *Process units*. See also *Feedback handling* on page 115.

Feedback 2 [unit] gives the signal value of the resulting feedback 2 (Term. 53). The unit is decided in parameter 415 *Process units*.

Feedback [unit] gives the resulting signal value using the unit/scaling selected in parameter 413 *Minimum feedback*, FB_{MIN} , 414 *Maximum feedback*, FB_{MAX} and 415 *Process units*.

Motor voltage [V] states the voltage supplied to the motor.

DC link voltage [V] states the intermediate circuit voltage in the VLT frequency converter.

Thermal load, motor [%] states the calculated/estimated thermal load on the motor. 100% is the cut-out limit. See also parameter 117 *Motor thermal protection*.

Thermal load, VLT [%] states the calculated/estimated thermal load on the VLT frequency converter. 100% is the cut-out limit.

Digital input [Binary code] states the signal status from the 8 digital inputs (16, 17, 18, 19, 27, 29, 32 and 33). Terminal 16 corresponds to the bit at the far left. '0' = no signal, '1' = connected signal.

Analogue input 53 [V] states the voltage value on terminal 53.

★ = factory setting. () = display text [] = value for use in communication via serial communication port

Analogue input 54 [V] states the voltage value on terminal 54.

Analogue input 60 [mA] states the voltage value on terminal 60.

Pulse reference [Hz] states a pulse frequency in Hz connected to terminal 17 or terminal 29.

External reference [%] gives the sum of the external references as a percentage (the sum of analogue/pulse/serial communication) in the range from *Minimum reference*, Ref_{MIN} to *Maximum reference*, Ref_{MAX} .

Heat sink temp. [°C] states the present heat sink temperature of the VLT frequency converter. The cut-out limit is $90 \pm 5^\circ\text{C}$; cutting back in occurs at $60 \pm 5^\circ\text{C}$.

LCD display text shows the text programmed in parameter 533 *Display text 1* and 534 *Display text 2* via the serial communication port.

008 Small display readout 1.1

(SMALL READOUT 1)

Value:

See parameter 007 *Large display readout*

★ Reference [Unit] [2]

Function:

This parameter enables a choice of the first of three data values to be shown on the display, line 1, position 1.

This is a useful function, i.a. when setting the PID regulator, in order to see how the process reacts to a change of reference.

For display read-outs, press the [DISPLAY/STATUS] button. Data option *LCP display text* [27] cannot be selected with small display readout.

Description of choice:

There is a choice of 26 different data values, see parameter 007 *Large display readout*.

009 Small display readout 1.2

(SMALL READOUT 2)

Value:

See parameter 007 *Large display readout*

★ Motorcurrent [A] [5]

Function:

See the functional description for parameter 008 Small display readout.

Description of choice:

There is a choice of 26 different data values, see parameter 007 *Large display readout*.

010 Small display readout 1.3

(SMALL READOUT 3)

Value:

See parameter 007 *Large display readout*

★ Power [kW] [6]

Function:

See the functional description for parameter 008 *Small data readout*.

Description of choice:

There is a choice of 26 different data values, see parameter 007 *Large display readout*.

011 Unit of local reference

(UNIT OF LOC REF)

Value:

★ Hz (HZ) [0]

% of output frequency range (%) (% OF FMAX) [1]

Function:

This parameter decides the local reference unit.

Description of choice:

Choose the required unit for local reference.

012 Hand start on LCP

(HAND START BTTN)

Value:

Disable (DISABLE) [0]

★ Enable (ENABLE) [1]

Function:

This parameter allows selection/deselection of the Hand start key on the control panel.

Description of choice:

If *Disable* [0] is selected in this parameter, the [HAND START] key will be inactive.

★ = factory setting. () = display text [] = value for use in communication via serial communication port

013 OFF/STOP on LCP (STOP BUTTON)
Value:

- | | |
|-------------------|-----|
| Disable (DISABLE) | [0] |
| ★ Enable (ENABLE) | [1] |

Function:

This parameter allows selection/deselection of the local stop key on the control panel.

Description of choice:

If *Disable* [0] is selected in this parameter, the [OFF/STOP] key will be inactive.

NB!

If *Disable* is selected, the motor cannot be stopped by means of the [OFF/STOP] key.

014 Auto start on LCP (AUTO START BTTN)
Value

- | | |
|-------------------|-----|
| Disable (DISABLE) | [0] |
| ★ Enable (ENABLE) | [1] |

Function:

This parameter allows selection/deselection of the auto start key on the control panel.

Description of choice:

If *Disable* [0] is selected in this parameter, the [AUTO START] key will be inactive.

015 Reset on LCP (RESET BUTTON)
Value:

- | | |
|-------------------|-----|
| Disable (DISABLE) | [0] |
| ★ Enable (ENABLE) | [1] |

Function:

This parameter allows selection/deselection of the reset key on the control panel.

Description of choice:

If *Disable* [0] is selected in this parameter, the [RESET] key will be inactive.

NB!

Only select *Disable* [0] if an external reset signal has been connected via the digital inputs.

016 Lock for data change
(DATA CHANGE LOCK)
Value:

- | | |
|---------------------------|-----|
| ★ Not locked (NOT LOCKED) | [0] |
| Locked (LOCKED) | [1] |

Function:

This parameter allows the control panel to be 'locked', which means that it is not possible to carry out data modifications via the control unit.

Description of choice:

If *Locked* [1] is selected, data modifications in the parameters cannot be made, although it will still be possible to carry out data modifications via the bus. Parameters 007-010 *Display readout* can be changed via the control panel.

It is also possible to lock for data modifications in these parameters by means of a digital input, see parameters 300-307 *Digital inputs* on page 97.

017 Operating state at power up, local
control (POWER UP ACTION)
Value:

- | | |
|-------------------------------|-----|
| ★ Auto restart (AUTO RESTART) | [0] |
| OFF/Stop (OFF/STOP) | [1] |

Function:

Setting of the desired operating mode when the mains voltage is reconnected.

Description of choice:

Auto restart [0] is selected if the VLT frequency converter is to start up in the same start/stop condition as immediately before power to the converter is cut off. *OFF/Stop* [1] is selected if the VLT frequency converter is to remain stopped when the mains voltage is connected, until a start command is active. To restart, activate the key [HAND START] or [AUTO START] by using the control panel.

NB!

If [HAND START] or [AUTO START] cannot be activated by the keys on the control panel (see parameter 012/014 *Hand/Auto start on LCP*) the motor will not be able to restart if *OFF/Stop* [1] is selected.

If *Handstart* or *Autostart* has been programmed for activation via the digital inputs, the motor will not be able to restart if *OFF/Stop* [1] is selected.

■ Load and Motor 100-117

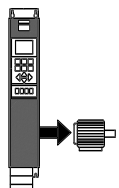

This parameter group allows the configuration of regulation parameters and the choice of torque characteristics to which the VLT frequency converter is to be adapted.

The motor nameplate data must be set and automatic motor adaptation can be carried out. In addition, DC brake parameters can be set and the motor thermal protection can be activated.

■ Configuration

The selection of configuration and torque characteristics influences the parameters that can be seen in the display. If *Open loop* [0] is selected, all parameters relating to PID regulation will be hidden.

Consequently, the user is only able to see the parameters that are of significance for a given application.

100 Configuration (CONFIG. MODE)

Value:

- ★ Open loop (OPEN LOOP) [0]
- Closed loop (CLOSED LOOP) [1]

Function:

This parameter is used for selecting the configuration to which the VLT frequency converter is to be adapted.

Description of choice:

If *Open loop* [0] is selected, normal speed control is obtained (without feedback signal), i.e. if the reference is changed, the motor speed will change.

If *Closed loop* [1] is selected, the internal process regulator is activated to enable accurate regulation in relation to a given process signal.

The reference (setpoint) and the process signal (feedback) can be set to a process unit as programmed in parameter 415 *Process units*.

See *Feedback handling* on page 115.

101 Torque characteristics

(VT CHARACT)

Value:

- ★ Automatic Energy Optimisation (AEO FUNCTION) [0]
- Parallel motors (MULTIPLE MOTORS) [1]

Function:

This parameter allows a choice of whether the VLT frequency converter has one or several motors connected to it.

Description of choice:

If *Automatic Energy Optimisation* [0] has been selected, only one motor may be connected to the VLT frequency converter. The AEO function ensures that the motor obtains its maximum efficiency and minimises motor interference.

Select *Parallel motors* [1] if more than one motor is connected to the output in parallel. See the description under parameter 108 *Start voltage of parallel motors* regarding the setting of parallel motor start voltages.

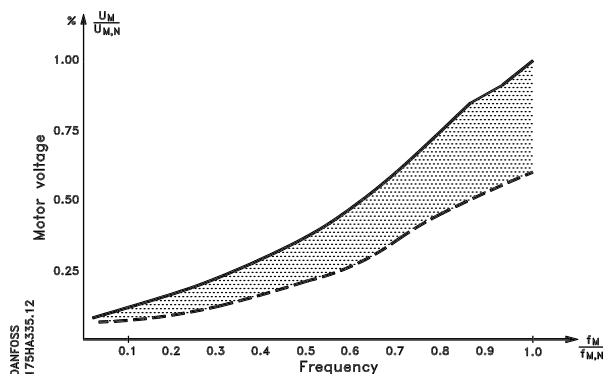

★ = factory setting. () = display text [] = value for use in communication via serial communication port



NB!

It is important that the values set in parameters 102-106 *Nameplate data* correspond to the nameplate data of the motor with respect to either star coupling Y or delta coupling Δ.

102 Motor power, P_{M,N} (MOTOR POWER)

Value:

0.25 kW (0.25 KW)	[25]
0.37 kW (0.37 KW)	[37]
0.55 kW (0.55 KW)	[55]
0.75 kW (0.75 KW)	[75]
1.1 kW (1.10 KW)	[110]
1.5 kW (1.50 KW)	[150]
2.2 kW (2.20 KW)	[220]
3 kW (3.00 KW)	[300]
4 kW (4.00 KW)	[400]
5,5 kW (5.50 KW)	[550]
7,5 kW (7.50 KW)	[750]
11 kW (11.00 KW)	[1100]
15 kW (15.00 KW)	[1500]
18.5 kW (18.50 KW)	[1850]
22 kW (22.00 KW)	[2200]
30 kW (30.00 KW)	[3000]
37 kW (37.00 KW)	[3700]
45 kW (45.00 KW)	[4500]
55 kW (55.00 KW)	[5500]
75 kW (75.00 KW)	[7500]
90 kW (90.00 KW)	[9000]
110 kW (110.00 KW)	[11000]
132 kW (132.00 KW)	[13200]
160 kW (160.00 KW)	[16000]
200 kW (200.00 KW)	[20000]
250 kW (250.00 KW)	[25000]
300 kW (300.00 KW)	[30000]

★ Depends on the unit

Function:

This is where to select the kW value P_{M,N} that corresponds to the rated power of the motor. At the works, a rated kW value P_{M,N} has been selected that depends on the type of unit.

Description of choice:

Select a value that equals the nameplate data on the motor. There are 4 possible undersizes or 1 oversize in comparison with the factory setting.

Also, alternatively it is possible to set the value for motor power as an infinitely variable value, see the procedure on page 73.

103 Motor voltage, U_{M,N}

(MOTOR VOLTAGE)

Value:

200 V	[200]
208 V	[208]
220 V	[220]
230 V	[230]
240 V	[240]
380 V	[380]
400 V	[400]
415 V	[415]
440 V	[440]
460 V	[460]
480 V	[480]
500 V	[500]

★ Depends on the unit

Function:

This is where the rated motor voltage U_{M,N} is set for either star Y or delta Δ.

Description of choice:

Select a value that equals the nameplate data on the motor, regardless of the mains voltage of the VLT frequency converter. Furthermore, alternatively it is possible to set the value of the motor voltage infinitely variably, see also the procedure on page 73.

★ = factory setting. () = display text [] = value for use in communication via serial communication port

**104 Motor frequency, $f_{M,N}$
(MOTOR FREQUENCY)**

Value:

★ 50 Hz (50 Hz)	[50]
60 Hz (60 Hz)	[60]

Function:
This is where the rated motor frequency $f_{M,N}$ is selected.

Description of choice:
Select a value that equals the nameplate data on the motor.
Furthermore, it is also possible to set the value for motor frequency infinitely variably in the 24-1000 Hz range.

105 Motor current, $I_{M,N}$ (MOTOR CURRENT)

Value:
0.01 - $I_{VLT,MAX}$ A ★Depends on the choice of motor.

Function:
The rated motor current $I_{M,N}$ forms part of the VLT frequency converter calculations i.a. of torque and motor thermal protection. Set the motor current $I_{VLT,N}$, taking into account the star Y or delta Δ connected motor.

Description of choice:
Set a value that equals the nameplate data on the motor.

 **NB!**
It is important to enter the correct value, since this forms part of the V V C^{PLUS} control feature.

**106 Rated motor speed, $n_{M,N}$
(MOTOR NOM. SPEED)**

Value:
100 - $f_{M,N} \times 60$ (max. 60000 rpm)
★ Depends on parameter 102 *Motor power, $P_{M,N}$* .

Function:
This is where the value is set that corresponds to the rated motor speed $n_{M,N}$, which can be seen from the nameplate data.

Description of choice:
Choose a value that corresponds to the motor nameplate data.

 **NB!**
It is important to set the correct value, since this forms part of the V V C^{PLUS} control feature.
The max. value equals $f_{M,N} \times 60$.
 $f_{M,N}$ is set in parameter 104 *Motor frequency, $f_{M,N}$* .

**107 Automatic motor adaptation, AMA
(AUTO MOTOR ADAPT)**

Value:

★ Optimisation disable (NO AMA)	[0]
Automatic adaptation (RUN AMA)	[1]
Automatic adaptation with LC-filter (RUN AMA WITH LC-FILT)	[2]

Function:
Automatic motor adaptation is a test algorithm that measures the electrical motor parameters at motor standstill. This means that AMA itself does not supply any torque.
AMA is useful when commissioning systems, where the user wants to optimise the adjustment of the VLT frequency converter to the motor applied. This feature is used in particular where the factory setting does not adequately cover the motor in question.

For the best adjustment of the VLT frequency converter, it is recommended to carry out AMA on a cold motor.
It must be noted that repeated AMA runs may lead to a heating of the motor that will result in an increase of the stator resistance R_s . However, this is not normally critical.

★ = factory setting. () = display text [] = value for use in communication via serial communication port

It is possible via parameter 107 *Automatic motor adaptation, AMA* to choose whether a complete automatic motor adaptation *Automatic adaptation* [1] is to be carried out, or whether reduced automatic motor adaptation *Automatic adaptation with LC-filter* [2] is to be made.

It is only possible to carry out the reduced test if a LC-filter has been placed between the VLT frequency converter and the motor. If a total setting is required, the LC-filter can be removed and, after completion of the AMA, it can be reinstalled. In *Automatic optimisation with LC-filter* [2] there is no test of motor symmetry and of whether all motor phases have been connected. The following must be noted when the AMA function is used:

- For AMA to be able to determine the motor parameters optimally, the correct nameplate data for the motor connected to the VLT frequency converter must be entered in parameters 102 to 106.
- The duration of a total automatic motor adaptation varies from a few minutes to approx. 10 minutes for small motors, depending on the rating of the motor used (the time for a 7.5 kW motor, for example, is approx. 4 minutes).
- Alarms and warnings will be shown in the display if faults occur during motor adaptation.
- AMA can only be carried out if the rated motor current of the motor is min. 35% of the rated output current of the VLT frequency converter.
- If automatic motor adaptation is to be discontinued, press the [OFF/STOP] key.

NB!

AMA is not allowed on motors connected in parallel.

Description of choice:

Select *Automatic adaptation* [1] if the VLT frequency converter is to carry out a complete automatic motor adaptation.

Select *Automatic adaptation with LC-filter* [2] if a LC-filter has been placed between the VLT frequency converter and the motor.

Procedure for automatic motor adaptation:

1. Set the motor parameters in accordance with the motor nameplate data given in parameters 102-106 *Nameplate data*.
2. Connect 24 V DC (possibly from terminal 12) to terminal 27 on the control card.
3. Select Automatic adaptation [1] or Automatic adaptation with LC-filter [2] in parameter 107 *Automatic motor adaptation, AMA*.

★ = factory setting. () = display text [] = value for use in communication via serial communication port

4. Start up the VLT frequency converter or connect terminal 18 (start) to 24 V DC (possibly from terminal 12).
5. After a normal sequence, the display reads: AMA STOP. After a reset, the VLT frequency converter will be ready to start operation again.

If the automatic motor adaptation is to be stopped:

1. Press the [OFF/STOP] key.

If there is a fault, the display reads:
ALARM 22

1. Press the [Reset] key.
2. Check for possible causes of the fault in accordance with the alarm message. See page 101.

If there is a warning, the display reads:
WARNING 39-42

1. Check for possible causes of the fault in accordance with the warning. See page 101.
2. Press the [CHANGE DATA] key and select "Continue" if AMA is to continue despite the warning, or press the [OFF/STOP] key to stop the automatic motor adaptation.

**108 Start voltage of parallel motors
(MULTIM.START VOLT)**
Value:

0.0 - parameter 103 *Motor voltage, U_{M,N}*

★ depends on par. 103 *Motor voltage, U_{M,N}*

Function:

This parameter specifies the start-up voltage of the permanent VT characteristics at 0 Hz for motors connected in parallel.

The start-up voltage represents a supplementary voltage input to the motor. By increasing the start-up voltage, motors connected in parallel receive a higher start-up torque. This is used especially for small motors (< 4.0 kW) connected in parallel, as they have a higher stator resistance than motors above 5.5 kW. This function is only active if *Parallel motors* [1] has been selected in parameter 101 *Torque characteristics*.

Description of choice:

Set the start-up voltage at 0 Hz. The maximum voltage depends on parameter 103 *Motor voltage, U_{M,N}*.

**109 Resonance damping
(RESONANCE DAMP.)**
Value:

 0 - 500 % ★ 100 %
Function:

High-frequency electric resonance problems between the VLT frequency converter and the motor can be eliminated by adjusting the resonance damping.

Description of choice:

Adjust the damping percentage until the motor resonance has disappeared.

**110 High break-away torque
(HIGH START TORQ.)**
Value:

 0.0 - 0.5 sec. ★ 0.0 sec.
Function:

In order to secure a high starting torque, the maximum torque for max. 0.5 sec. is allowed. However, the current is limited by the protection limit of the VLT frequency converter (inverter). 0 sec. corresponds to no high break-away torque.

Description of choice:

Set the necessary time in which a high starting torque is desired.

111 Start delay (START DELAY)
Value:

 0.0 - 120.0 sec. ★ 0.0 sec.
Function:

This parameter enables a delay of the starting time after the conditions for start have been fulfilled. When the time has passed, the output frequency will start by ramping up to the reference.

Description of choice:

Set the desired time until acceleration is to begin.

112 Motor preheater (MOTOR PREHEAT)
Value:

 ★ Disable (DISABLE) [0]
 Enable (ENABLE) [1]
Function:

The motor preheater ensures that no condensate develops in the motor at stop. This function can also be used to evaporate condensed water in the motor. The motor preheater is only active during stop.

Description of choice:

Select *Disable* [0] if this function is not required. Select *Enable* [1] to activate motor preheating. The DC current is set in parameter 113 *Motor preheater DC current*.

**113 Motor preheater DC current
(PREHEAT DC-CURR.)**
Value:

 0 - 100 % ★ 50 %

The maximum value depends on the rated motor current, parameter 105 *Motor current*, $I_{M,N}$.

Function:

The motor can be preheated at stop by means of a DC current to prevent moisture from entering the motor.

Description of choice:

The motor can be preheated by means of a DC current. At 0%, the function is inactive; at a value higher than 0%, a DC current will be supplied to the motor at stop (0 Hz). In fans that rotate because of the air flow when they are not in operation (windmilling), this function can also be used to generate a holding torque.



If too high a DC current is supplied for too long, the motor can be damaged.

■ **DC braking**

In DC braking, the motor receives a DC current that brings the shaft to a halt. Parameter 114 *DC braking current*, decides the DC braking current as a percentage of the rated motor current $I_{M,N}$. In parameter 115 *DC braking time*, the DC braking time is selected, and in parameter 116 *DC brake cut-in frequency*, the frequency is selected at which DC braking becomes active.

If terminal 19 or 27 (parameter 303/304 *Digital input*) has been programmed to *DC braking inverse* and shifts from logic '1' to logic '0', the DC braking will be activated.

When the start signal on terminal 18 changes from logic '1' to logic '0', the DC braking will be activated when the output frequency becomes lower than the brake coupling frequency.



NB!

The DC brake is not to be used if the inertia of the motor shaft is more than 20 times the inertia of the motor itself.

**114 DC braking current
(DC BRAKE CURRENT)**

Value:

$$0 - \frac{I_{VLT,MAX}}{I_{M,N}} \times 100 \text{ [%]} \quad \star 50 \%$$

The maximum value depends on the rated motor current. If the DC braking current is active, the VLT frequency converter has a switching frequency of 4 kHz.

Function:

This parameter is used for setting the DC braking current that is activated upon a stop when the DC brake frequency set in parameter 116 *DC brake cut-in frequency* has been reached, or if DC brake inverse is active via terminal 27 or via the serial communication port. The DC braking current will be active for the duration of the DC braking time set in parameter 115 *DC braking time*.

Description of choice:

To be set as a percentage value of the rated motor current $I_{M,N}$ set in parameter 105 *Motor current*, $I_{VLT,N}$. 100% DC braking current corresponds to $I_{M,N}$.



Make sure not to supply too high a braking current for too long, since otherwise the motor will be damaged because of mechanical overload or the heat generated in the motor.

**115 DC braking time
(DC BRAKE TIME)**

Value:

0.0 - 60.0 sec. ★ 10.0 sec.

Function:

This parameter is for setting the DC braking time for which the DC braking current (parameter 113) is to be active.

Description of choice:

Set the desired time.

**116 DC brake cut-in frequency
(DC BRAKE CUT-IN)**

Value:

0.0 (OFF) - par. 202 *Output frequency high limit*, f_{MAX} ★ OFF

Function:

This parameter is used for setting the DC brake cut-in frequency at which DC braking is to be activated in connection with a stop command.

Description of choice:

Set the desired frequency.

★ = factory setting. () = display text [] = value for use in communication via serial communication port

117 Motor thermal protection (MOT. THERM PROTEC)	
Value:	
No protection (NO PROTECTION)	[0]
Thermistor warning (THERMISTOR WARNING)	[1]
Thermistor trip (THERMISTOR FAULT)	[2]
ETR Warning 1 (ETR WARNING 1)	[3]
★ETR Trip 1 (ETR TRIP 1)	[4]
ETR Warning 2 (ETR WARNING 2)	[5]
ETR Trip 2 (ETR TRIP 2)	[6]
ETR Warning 3 (ETR WARNING 3)	[7]
ETR Trip 3 (ETR TRIP 3)	[8]
ETR Warning 4 (ETR WARNING 4)	[9]
ETR Trip 4 (ETR TRIP 4)	[10]

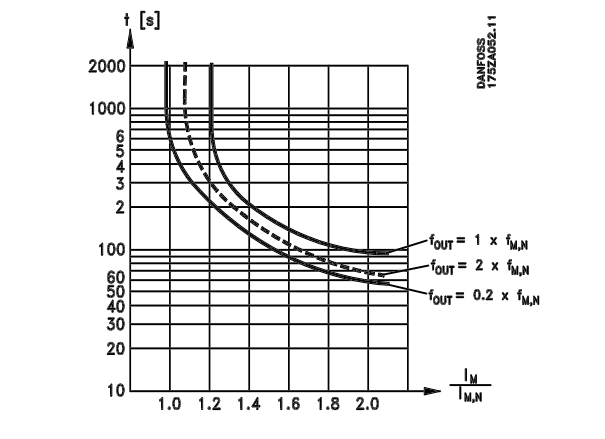

Function:

The VLT frequency converter is able to monitor the motor temperature in two different ways:

- Via a thermistor sensor fitted to the motor. The thermistor is connected to one of the analogue input terminals 53 and 54.
- Calculation of the thermal load (ETR - Electronic Thermal Relay), based on the current load and the time. This is compared with the rated motor current $I_{M,N}$ and the rated motor frequency $f_{M,N}$. The calculations made take into account the need for a lower load at lower speeds because of less cooling in the motor itself.

ETR functions 1-4 do not start calculating the load until there is a switch-over to the Setup in which they were selected. This enables the use of the ETR function, even where two or several motors alternate.

Description of choice:

Select *No protection* [0] if no warning or tripping is required when the motor is overloaded.

Select *Thermistor warning* [1] if a warning is desired when the connected thermistor gets too hot.

Select *Thermistor trip* [2] if cutting out (trip) is desired when the connected thermistor overheats.

Select *ETR Warning 1-4*, if a warning is to come up on the display when the motor is overloaded according to the calculations.

The VLT frequency converter can also be programmed to give off a warning signal via one of the digital outputs.

Select *ETR Trip 1-4* if tripping is desired when the motor is overloaded according to the calculations.

★ = factory setting. () = display text [] = value for use in communication via serial communication port

■ References & Limits 200 - 228

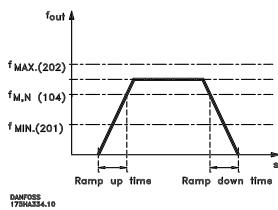

In this parameter group, the frequency and reference range of the VLT frequency converter are established.

This parameter group also includes:

- Setting of ramp times
- Choice of four preset references
- Possibility of programming four bypass frequencies.
- Setting of maximum current to motor.
- Setting of warning limits for current, frequency, reference and feedback.

200 Output frequency range (FREQUENCY RANGE)

Value:

- ★ 0 - 120 Hz (0 - 120 HZ) [0]
- 0 - 1000 Hz (0 - 1000 HZ) [1]

Function:

This is where to select the maximum output frequency range to be set in parameter 202 *Output frequency high limit, f_{MAX}*.

Description of choice:

Select the required output frequency range.

201 Output frequency low limit, f_{MIN} (MIN. FREQUENCY)

Value:

- 0.0 - f_{MAX} ★ 0.0 Hz

Function:

This is where to select the maximum output frequency range to be set in parameter 202 *Output frequency high limit, f_{MAX}*.

Description of choice:

A value from 0.0 Hz to the *Output frequency high limit, f_{MAX}* frequency set in parameter 202 can be selected.

202 Output frequency high limit, f_{MAX} (MAX. FREQUENCY)

Value:

- f_{MIN} - 120/1000 Hz (par. 200 *Output frequency range*) ★ 50 Hz

Function:

In this parameter, a maximum output frequency limit can be selected that corresponds to the highest speed at which the motor can be.



NB!

The output frequency of the VLT frequency converter can never assume a value higher than 1/10 of the switching frequency (parameter 407 *Switching frequency*).

Description of choice:

A value from f_{MIN} to the choice made in parameter 200 *Output frequency range* can be selected.

★ = factory setting. () = display text [] = value for use in communication via serial communication port

■ Reference handling

Reference handling is shown in the block diagram underneath.

The block diagram shows how a change in a parameter can affect the resulting reference.

Parameters 203 to 205 *Reference handling, minimum and maximum reference* and parameter 210 *Reference type* define the way reference handling can be carried out. The mentioned parameters are active both in a closed and in an open loop.

Remote references are defined as:

- External references, such as analogue inputs 53, 54 and 60, pulse reference via terminal 17/29 and reference from serial communication.
- Preset references.

The resulting reference can be shown in the display by selecting *Reference [%]* in parameters 007-010 *Display readout* and in the form of a unit by selecting *Remote reference [unit]*.

See the section on *Feedback handling* in connection with a closed loop on page 115.

The sum of the external references can be shown in the display as a percentage of the range from *Minimum reference, Ref_{MIN}* to *Maximum reference, Ref_{MAX}*. Select *External reference, % [25]* in parameters 007-010 *Display readout* if a readout is required.

It is possible to have both preset references and external references at the same time. In parameter 210 *Reference type* a choice is made of how the preset references are to be added to the external references.

Furthermore, an independent local reference exists, where the resulting reference is set by means of the [+/-] keys. If local reference has been selected, the output frequency range is limited by parameter 201 *Output frequency low limit, f_{MIN}* and parameter 202 *Output frequency high limit, f_{MAX}*.

NB!



If the local reference is active, the VLT frequency converter will always be in *Open loop [0]*, regardless of the choice made in parameter 100 *Configuration*.

The unit of the local reference can be set either as Hz or as a percentage of the output frequency range. The unit is selected in parameter 011 *Unit of local reference*.

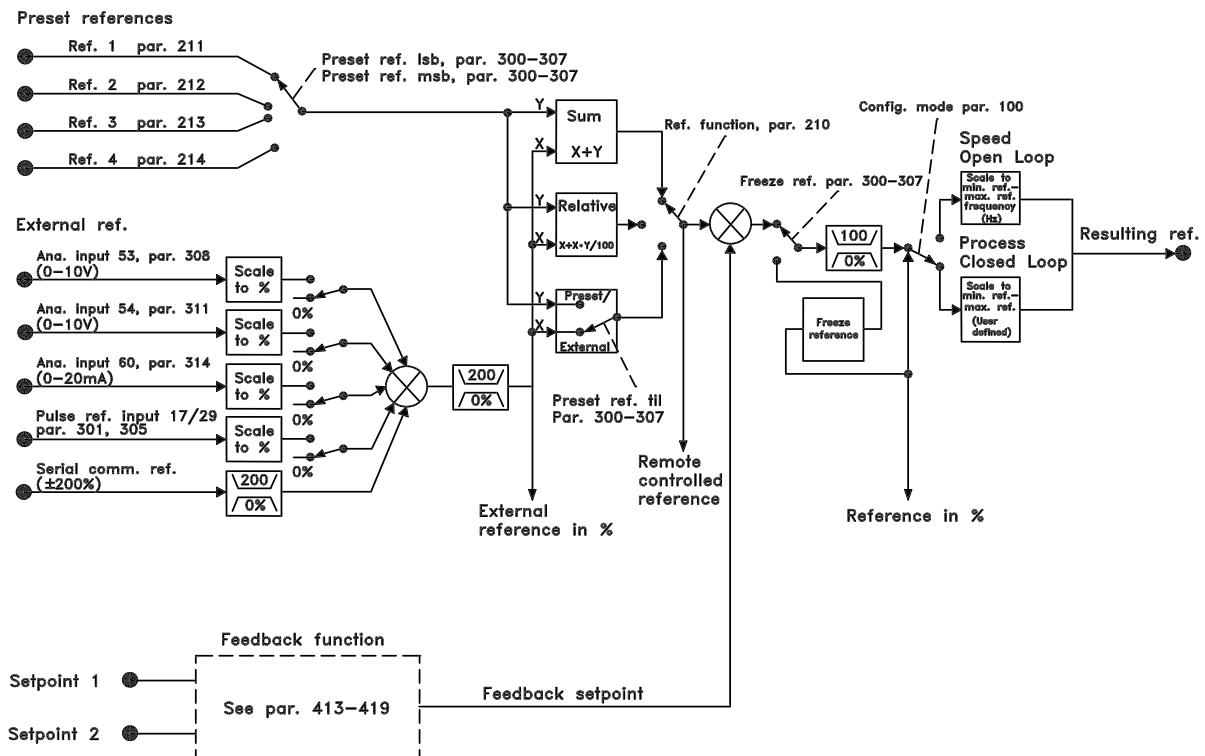

DANFOSS
175HA375.13

★ = factory setting. () = display text [] = value for use in communication via serial communication port

**203 Reference site
(REFERENCE SITE)**

Value:

★ Hand/Auto linked reference (LINKED TO HAND/AUTO))	[0]
Remote reference (REMOTE)	[1]
Local reference (LOCAL)	[2]

Function:

This parameter decides which resulting reference is to be active. If *Hand/Auto linked reference* [0] is selected, the resulting reference will depend on whether the VLT frequency converter is in Hand or Auto mode. The table shows which references are active when *Hand/Auto linked reference* [0], *Remote reference* [1] or *Local reference* [2] has been selected. The Hand mode or Auto mode can be selected via the control keys or via a digital input, parameters 300-307 *Digital inputs*.

Reference

handling	Hand mode	Auto mode
Hand/Auto [0]	Local ref. active	Remote ref. active
Remote [1]	Remote ref. active	Remote ref. active
Local [2]	Local ref. active	Local ref. active

Description of choice:

If *Hand/Auto linked reference* [0] is chosen, the motor speed in Hand mode will be decided by the local reference, while in Auto mode it depends on remote references and any setpoints selected.

If *Remote reference* [1] is selected, the motor speed will depend on remote references, regardless of whether Hand mode or Auto mode has been chosen. If *Local reference* [2] is selected, the motor speed will only depend on the local reference set via the control panel, regardless of whether Hand mode or Auto mode has been selected.

**204 Minimum reference, Ref_{MIN}
(MIN. REFERENCE)**

Value:

Parameter 100 *Configuration* = *Open loop* [0].
 0.000 - parameter 205 Ref_{MAX} ★ 0.000 Hz

Parameter 100 *Configuration* = *Closed loop* [1].
 -Par. 413 *Minimum feedback*
 - par. 205 Ref_{MAX} ★ 0.000

Function:

The *Minimum reference* gives the minimum value that can be assumed by the sum of all references. If *Closed loop* has been selected in parameter 100 *Configuration*, the minimum reference is limited by parameter 413 *Minimum feedback*. Minimum reference is ignored when the local reference is active (parameter 203 *Reference site*). The unit for the reference can be seen from the following table:

	Unit
Par. 100 <i>Configuration</i> = <i>Open loop</i>	Hz
Par. 100 <i>Configuration</i> = <i>Closed loop</i>	Par. 415

Description of choice:

Minimum reference is set if the motor is to run at a minimum speed, regardless of whether the resulting reference is 0.

**205 Maximum reference, Ref_{MAX}
(MAX. REFERENCE)**

Value:

Parameter 100 *Configuration* = *Open loop* [0]
 Parameter 204 Ref_{MIN} - 1000.000 Hz ★ 50.000 Hz

Parameter 100 *Configuration* = *Closed loop* [1]
 Par. 204 Ref_{MIN}
 - par. 414 *Maximum feedback* ★ 50.000 Hz

Function:

The *Maximum reference* gives the maximum value that can be assumed by the sum of all references. If *Closed loop* [1] has been selected in parameter 100 *Configuration*, the maximum reference cannot be set above parameter 414 *Maximum feedback*. The *Maximum reference* is ignored when the local reference is active (parameter 203 *Reference site*).

★ = factory setting. () = display text [] = value for use in communication via serial communication port

Function, cont.:

The reference unit can be determined on the basis of the following table:

	Unit
Par. 100 Configuration = Open loop	Hz
Par. 100 Configuration = Closed loop	Par. 415

Description of choice:

Maximum reference is set if the motor speed is not to exceed the set value, regardless of whether the resulting reference is higher than *Maximum reference*.

206 Ramp-up time (RAMP UP TIME)

Value:

1 - 3600 sec. ★ Depends on the unit

Function:

The ramp-up time is the acceleration time from 0 Hz to the rated motor frequency $f_{M,N}$ (parameter 104 *Motor frequency, $f_{M,N}$*). It is assumed that the output current does not reach the current limit (set in parameter 215 *Current limit I_{LIM}*).

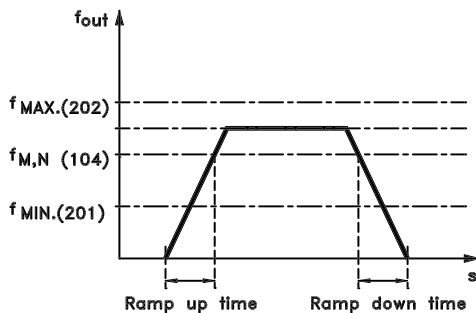

DANFOSS
175HA334.10

Description of choice:

Program the desired ramp-up time.

207 Ramp-down time (RAMP DOWN TIME)

Value:

1 - 3600 sec. ★ Depends on the unit

Function:

The ramp-down time is the deceleration time from the rated motor frequency $f_{M,N}$ (parameter 104 *Motor frequency, $f_{M,N}$*) to 0 Hz, provided there is no overvoltage in the inverter because of the motor acting as a generator.

Description of choice:

Program the desired ramp-down time.

208 Automatic ramp-up/down (AUTO RAMPING)

Value:

- Disable (DISABLE) [0]
- ★ Enable (ENABLE) [1]

Function:

This function ensures that the VLT frequency converter does not trip during deceleration if the ramp-down time set is too short. If, during deceleration, the VLT frequency converter registers that the intermediate circuit voltage is higher than the max. value (see page 101), the VLT frequency converter automatically extends the ramp-up and ramp-down time.



NB!

If the function is chosen as *Enable* [1], the ramp time may be considerably extended in relation to the time set in parameter 207 *Ramp-down time*.

Description of choice:

Program this function as *Enable* [1] if the VLT frequency converter periodically trips during ramp-down. If a quick ramp-down time has been programmed that may lead to a trip under special conditions, the function can be set to *Enable* [1] to avoid trips.

209 Jog frequency (JOG FREQUENCY)

Value:

Par. 201 *Output frequency Low limit* - par. 202
Output frequency high limit ★ 10.0 Hz

Function:

The jog frequency f_{JOG} is the fixed output frequency at which the VLT frequency converter is running when the jog function is activated. Jog can be activated via the digital inputs.

Description of choice:

Set the desired frequency.

■ **Reference type**

The example shows how the resulting reference is calculated when Preset references are used together with Sum and Relative in parameter 210 Reference type. A formula for calculating the resulting reference is given on page 156.

See also the drawing on page 89.

The following parameters have been set:

Par. 204 <i>Minimum reference:</i>	10 Hz
Par. 205 <i>Maximum reference:</i>	50 Hz
Par. 211 <i>Preset reference:</i>	15%
Par. 308 <i>Terminal 53, analogue input:</i>	Reference [1]
Par. 309 <i>Terminal 53, min. scaling:</i>	0 V
Par. 310 <i>Terminal 53, max. scaling:</i>	10 V

When parameter 210 *Reference type* is set to Sum [0], one of the adjusted *Preset references* (par. 211-214) will be added to the external references as a percentage of the reference range. If terminal 53 is energized by an analogue input voltage of 4 V, the resulting reference will be as follows:

Par. 210 <i>Reference type = Sum</i> [0]	
Par. 204 <i>Minimum reference</i>	= 10.0 Hz
Reference contribution at 4 V	= 16.0 Hz
<u>Par. 211 <i>Preset reference</i></u>	= <u>6.0 Hz</u>
Resulting reference	= 32.0 Hz

If parameter 210 *Reference type* is set to *Relative* [1], one of the adjusted *Preset references* (par. 211-214) will be totaled as a percentage of the sum of the present external references. If terminal 53 is energized by an analogue input voltage of 4 V, the resulting reference will be as follows:

Par. 210 <i>Reference type = Relative</i> [1]	
Par. 204 <i>Minimum reference</i>	= 10.0 Hz
Reference contribution at 4 V	= 16.0 Hz
<u>Par. 211 <i>Preset reference</i></u>	= <u>2.4 Hz</u>
Resulting reference	= 28.4 Hz

The graph in the next column shows the resulting reference in relation to the external reference varied from 0-10 V. Parameter 210 *Reference type* has been programmed for *Sum* [0] and *Relative* [1], respectively. In addition, a graph is shown in which parameter 211 *Preset reference 1* is programmed for 0%.

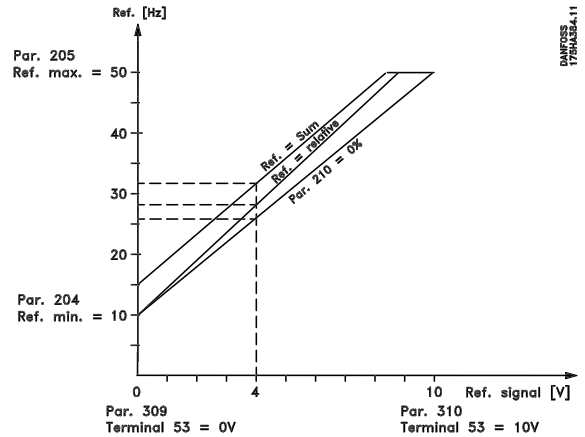

210 Reference type (REF. FUNCTION)

Value:	
★ Sum (SUM)	[0]
Relative (RELATIVE)	[1]
External/preset (EXTERNAL/PRESET)	[2]

Function:

It is possible to define how the preset references are to be added to the other references. For this purpose, *Sum* or *Relative* is used. It is also possible - by using the *External/preset* function - to select whether a shift between external references and preset references is wanted.

See *Reference handling* on page 89.

Description of choice:

If *Sum* [0] is selected, one of the adjusted preset references (parameters 211-214 *Preset reference*) is added to the other external references as a percentage of the reference range (Ref_{MIN}-Ref_{MAX}).

If *Relative* [1] is selected, one of the adjusted preset references (parameters 211-214 *Preset reference*) is totaled as a percentage of the sum of the present external references.

If *External/preset* [2] is selected, it is possible to shift between external references and preset references via terminal 16, 17, 29, 32 or 33 (parameter 300, 301, 305, 306 or 307 *Digital inputs*). Preset references will be a percentage value of the reference range. External reference is the sum of the analogue references, pulse references and any references from serial communication.



NB!

If *Sum* or *Relative* is selected, one of the preset references will always be active. If the preset references are to be without influence, they should be set to 0% (as in the factory setting) via the serial communication port.

★ = factory setting. () = display text [] = value for use in communication via serial communication port

211 Preset reference 1 (PRESET REF. 1)

212 Preset reference 2 (PRESET REF. 2)

213 Preset reference 3 (PRESET REF. 3)

214 Preset reference 4 (PRESET REF. 4)

Value:

-100.00 % - +100.00 % ★ 0.00%
of the reference range/external reference

Function:

Four different preset references can be programmed in parameters 211-214 *Preset reference*. The preset reference is stated as a percentage value of the reference range (Ref_{MIN} - Ref_{MAX}) or as a percentage of the other external references, depending on the choice made in parameter 210 *Reference type*.

The choice between the preset references can be made by activating terminal 16, 17, 29, 32 or 33, cf. the table below.

Terminal 17/29/33 preset ref. msb	Terminal 16/29/32 preset ref. lsb	
0	0	Preset ref. 1
0	1	Preset ref. 2
1	0	Preset ref. 3
1	1	Preset ref. 4

Description of choice:

Set the required preset reference(s) that is/are to be the options.

215 Current limit, I_{LIM} (CURRENT LIMIT)

Value:

0.1 - 1.1 x I_{VLT,N} ★ 1.0 x I_{VLT,N} [A]

Function:

This is where the maximum output current I_{LIM} is set. The factory setting corresponds to the rated output current. If the current limit is to be used as motor protection, the rated motor current must be set. If the current limit is set within the range of 1.0-1.1 x I_{VLT,N} (the rated output current of the VLT frequency converter), the VLT frequency converter can only handle a load intermittently, i.e. for short periods at a time. After the load has been higher than I_{VLT,N}, it must be ensured that for a period the load is lower than I_{VLT,N}.

Please note that if the current limit is set to less than I_{VLT,N}, the acceleration torque will be reduced correspondingly.

Description of choice:

Set the required maximum output current I_{LIM}.

216 Frequency bypass, bandwidth (FREQUENCY BYPASS B.W.)

Value:

0 (OFF) - 100 Hz ★ Disable

Function:

Some systems call for some output frequencies to be avoided because of mechanical resonance problems in the system.

These output frequencies can be programmed in parameters 217-220 *Frequency bypass*.

In this parameter (216 *Frequency bypass, bandwidth*), a definition can be given of a bandwidth around each of these frequencies.

Description of choice:

The bypass bandwidth is equal to the programmed bandwidth frequency. This bandwidth will be centered around each bypass frequency.

217 Frequency bypass 1 (BYPASS FREQ. 1)

218 Frequency bypass 2 (BYPASS FREQ. 2)

219 Frequency bypass 3 (BYPASS FREQ. 3)

220 Frequency bypass 4 (BYPASS FREQ. 4)

Value:

0 - 120/1000 Hz ★ 120.0 Hz
The frequency range depends on the selection made in parameter 200 *Output frequency range*.

Function:

Some systems call for some output frequencies to be avoided because of mechanical resonance problems in the system.

Description of choice:

Enter the frequencies to be avoided.

See also parameter 216 *Frequency bypass, bandwidth*.

221 Warning: Low current, I_{LOW}
(WARN. LOW CURR.)

Value:
0.0 - par. 222 *Warning: High current, I_{HIGH}* ★0.0A

Function:

When the motor current is below the limit, I_{LOW} , programmed in this parameter, the display shows a flashing CURRENT LOW, provided *Warning [1]* has been selected in parameter 409 *Function in case of no load*. The VLT frequency converter will trip if parameter 409 *Function in case of no load* has been selected as *Trip [0]*.

The warning functions in parameters 221-228 are not active during ramp-up after a start command, ramp-down after a stop command or while stop-ped. The warning functions are activated when the output frequency has reached the resulting reference. The signal outputs can be programmed to generate a warning signal via terminal 42 or 45 and via the relay outputs.

Description of choice:

The lower signal limit I_{LOW} must be programmed within the normal working range of the frequency converter.

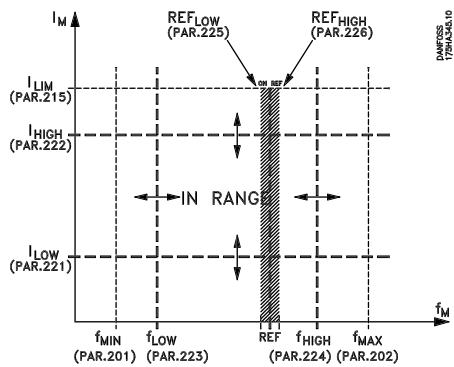

222 Warning: High current, I_{HIGH}
(WARN. HIGH CURR.)

Value:
Parameter 221 - $I_{VLT,MAX}$ ★ $I_{VLT,MAX}$

Function:

If the motor current is above the limit, I_{HIGH} , programmed in this parameter, the display shows a flashing CURRENT HIGH.

The warning functions in parameters 221-228 are not active during ramp-up after a start command, ramp-down after a stop command or while stop-ped. The warning functions are activated when the output frequency has reached the resulting reference. The signal outputs can be programmed to generate a warning signal via terminal 42 or 45 and via the relay outputs.

Description of choice:

The upper signal limit of the motor frequency, f_{HIGH} , must be programmed within the normal working range of the frequency converter. See drawing at parameter 221 *Warning: Low current, I_{LOW}* .

223 Warning: Low frequency, f_{LOW}
(WARN. LOW FREQ.)

Value:
0.0 - parameter 224 ★ 0.0 Hz

Function:

If the output frequency is below the limit, f_{LOW} , programmed in this parameter, the display will show a flashing FREQUENCY LOW.

The warning functions in parameters 221-228 are not active during ramp-up after a start command, ramp-down after a stop command or while stop-ped. The warning functions are activated when the output frequency has reached the resulting reference. The signal outputs can be programmed to generate a warning signal via terminal 42 or 45 and via the relay outputs.

Description of choice:

The lower signal limit of the motor frequency, f_{LOW} , must be programmed within the normal working range of the frequency converter. See drawing at parameter 221 *Warning: Low current, I_{LOW}* .

★ = factory setting. () = display text [] = value for use in communication via serial communication port

224 Warning: High frequency, f_{HIGH}
(WARN. HIGH FREQ.)
Value:

Par. 200 *Output frequency range* = 0-120 Hz [0].
 parameter 223 - 120 Hz ★ 120.0 Hz

Par. 200 *Output frequency range* = 0-1000 Hz [1].
 parameter 223 - 1000 Hz ★ 120.0 Hz

Function:

If the output frequency is above the limit, f_{HIGH} , programmed in this parameter, the display will show a flashing FREQUENCY HIGH.

The warning functions in parameters 221-228 are not active during ramp-up after a start command, ramp-down after a stop command or while stop-ped. The warning functions are activated when the output frequency has reached the resulting reference.

The signal outputs can be programmed to generate a warning signal via terminal 42 or 45 and via the relay outputs.

Description of choice:

The higher signal limit of the motor frequency, f_{HIGH} , must be programmed within the normal working range of the frequency converter. See drawing at parameter 221 *Warning: Low current, I_{LOW}* .

225 Warning: Low reference, REF_{LOW}
(WARN. LOW REF.)
Value:

-999,999.999 - REF_{HIGH} (parameter 226) ★ 0.0 Hz

Function:

When the remote reference lies under the limit, REF_{LOW} , programmed in this parameter, the display shows a flashing REFERENCE LOW.

The warning functions in parameters 221-228 are not active during ramp-up after a start command, ramp-down after a stop command or while stop-ped. The warning functions are activated when the output frequency has reached the resulting reference.

The signal outputs can be programmed to generate a warning signal via terminal 42 or 45 and via the relay outputs.

The reference limits in parameter 226 *Warning: High reference, Ref_{HIGH}* , and in parameter 227 *Warning: Low reference, Ref_{LOW}* , are only active when remote reference has been selected.

In *Open loop mode* the unit for the reference is Hz, while in *Closed loop mode* the unit is programmed in parameter 415 *Process units*.

Description of choice:

The lower signal limit, Ref_{LOW} , of the reference must be programmed within the normal working range of the frequency converter, provided parameter 100 *Configuration* has been programmed for *Open loop* [0]. In *Closed loop* [1] (parameter 100), Ref_{LOW} must be within the reference range programmed in parameters 204 and 205.

226 Warning: High reference, REF_{HIGH}
(WARN. HIGH REF.)
Value:

REF_{LOW} (parameter 225) - 999,999.999 ★ 50.0 Hz

Function:

If the resulting reference lies under the limit, Ref_{HIGH} , programmed in this parameter, the display shows a flashing REFERENCE HIGH.

The warning functions in parameters 221-228 are not active during ramp-up after a start command, ramp-down after a stop command or while stop-ped. The warning functions are activated when the output frequency has reached the resulting reference.

The signal outputs can be programmed to generate a warning signal via terminal 42 or 45 and via the relay outputs.

The reference limits in parameter 226 *Warning: High reference, Ref_{HIGH}* , and in parameter 227 *Warning: Low reference, Ref_{LOW}* , are only active when remote reference has been selected.

In *Open loop* the unit for the reference is Hz, while in *Closed loop* the unit is programmed in parameter 415 *Process units*.

★ = factory setting. () = display text [] = value for use in communication via serial communication port

Description of choice:

The upper signal limit, Ref_{HIGH}, of the reference must be programmed within the normal working range of the frequency converter, provided parameter 100 *Configuration* has been programmed for *Open loop* [0]. In *Closed loop* [1] (parameter 100), Ref_{HIGH} must be within the reference range programmed in parameters 204 and 205.

**227 Warning: Low feedback, FB_{LOW}
(WARN LOW FDBK)**
Value:

-999,999.999 - FB_{HIGH} (parameter 228)
★ -999.999,999

Function:

If the feedback signal is below the limit, FB_{LOW}, programmed in this parameter, the display will show a flashing FEEDBACK LOW.

The warning functions in parameters 221-228 are not active during ramp-up after a start command, ramp-down after a stop command or while stop-ped. The warning functions are activated when the output frequency has reached the resulting reference.

The signal outputs can be programmed to generate a warning signal via terminal 42 or 45 and via the relay outputs.

In *Closed loop*, the unit for the feedback is programmed in parameter 415 *Process units*.

Description of choice:

Set the required value within the feedback range (parameter 413 *Minimum feedback*, FB_{MIN}, and 414 *Maximum feedback*, FB_{MAX}).

**228 Warning: High feedback, FB_{HIGH}
(WARN. HIGH FDBK)**
Value:

FB_{LOW} (parameter 227) - 999,999.999
★ 999.999,999

Function:

If the feedback signal is above the limit, FB_{HIGH}, programmed in this parameter, the display will show a flashing FEEDBACK HIGH.

The warning functions in parameters 221-228 are not active during ramp-up after a start command, ramp-down after a stop command or while stop-ped. The warning functions are activated when the output frequency has reached the resulting reference.

The signal outputs can be programmed to generate a warning signal via terminal 42 or 45 and via the relay outputs.

In *Closed loop*, the unit for the feedback is programmed in parameter 415 *Process units*.

Description of choice:

Set the required value within the feedback range (parameter 413 *Minimum feedback*, FB_{MIN}, and 414 *Maximum feedback*, FB_{MAX}).

Inputs and outputs 300-328

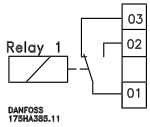

In this parameter group, the functions that relate to the input and output terminals of the VLT frequency converter are defined. The

digital inputs (terminals 16, 17, 18, 19, 27, 32 and 33) are programmed in parameters 300-307. The table below gives the options for programming the inputs. The digital inputs require a signal of 0 or 24 V DC. A signal lower than 5 V DC is a logic '0', while a signal higher than 10 V DC is a logic '1'.

The terminals for the digital inputs can be connected to the internal 24 V DC supply, or an external 24 V DC supply can be connected.

The drawings in the next column show one Setup using the internal 24 V DC supply and one Setup using an external 24 V DC supply.

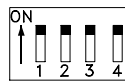
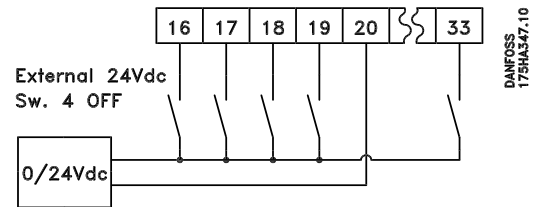
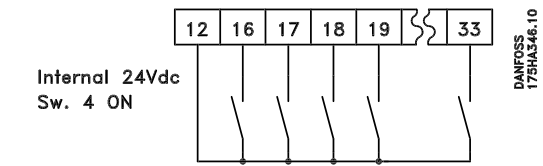

Switch 4, which is located on the Dip switch control card, is used for separating the common potential of the internal 24 V DC supply from the common potential of the external 24 V DC supply.

See also the drawing on page 37.

Please note that when Switch 4 is in the OFF position, the external 24 V DC supply is galvanically isolated from the VLT frequency converter.

Digital inputs	terminal no.	16	17	18	19	27	29	32	33
	parameter	300	301	302	303	304	305	306	307
Value:									
No function	(NO OPERATION)	[0]	[0]	[0]	[0]		[0]	★[0]	★[0]
Reset	(RESET)	★[1]	[1]				[1]	[1]	[1]
Coasting stop, inverse	(COAST INVERSE)					★[0]			
Reset and coasting stop, inverse	(RESET & COAST INVERSE)					[1]			
Start	(START)			★[1]					
Reversing	(REVERSE)				★[1]				
Reversing and start	(START REVERSE)				[2]				
DC-braking, inverse	(DC BRAKE INVERSE)				[3]	[2]			
Safety interlock	(SAFETY INTERLOCK)					[3]			
Freeze reference	(FREEZE REFERENCE)	[2]	★[2]				[2]	[2]	[2]
Freeze output	(FREEZE OUTPUT)	[3]	[3]				[3]	[3]	[3]
Selection of Setup, lsb	(SETUP SELECT LSB)	[4]					[4]	[4]	
Selection of Setup, msb	(SETUP SELECT MSB)		[4]				[5]		[4]
Preset reference, on	(PRESET REF. ON)	[5]	[5]				[6]	[5]	[5]
Preset reference, lsb	(PRESET REF. LSB)	[6]					[7]	[6]	
Preset reference, msb	(PRESET REF. MSB)		[6]				[8]		[6]
Speed down	(SPEED DOWN)		[7]				[9]		[7]
Speed up	(SPEED UP)	[7]					[10]	[7]	
Run permissive	(RUN PERMISSIVE)	[8]	[8]				[11]	[8]	[8]
Jog	(JOG)	[9]	[9]				★[12]	[9]	[9]
Data change lock	(PROGRAMMING LOCK)	[10]	[10]				[13]	[10]	[10]
Pulse reference	(PULSE REFERENCE)		[11]				[14]		
Pulse feedback	(PULSE FEEDBACK)								[11]
Hand start	(HAND START)	[11]	[12]				[15]	[11]	[12]
Auto start	(AUTOSTART)	[12]	[13]				[16]	[12]	[13]

★ = factory setting. () = display text [] = value for use in communication via serial communication port

Function:

In parameters 300-307 *Digital inputs* it is possible to choose between the different possible functions related to the digital inputs (terminals 16-33). The functional options are given in the table on the previous page.

Description of choice:

No function is selected if the VLT frequency converter is not to react to signals transmitted to the terminal.

Reset resets the VLT frequency converter after an alarm; however, not all alarms can be reset (trip locked) cycling mains power supply. See table on page 150. Reset will be activate on the rising edge of the signal.

Coasting stop, inverse is used to force the VLT frequency converter to "release" the motor immediately (the output transistors are "turned off") to make it coast freely to stop. Logic '0' implements coasting to stop.

Reset and coasting stop, inverse is used for activating coasting stop at the same time as reset. Logic '0' implements coasting stop and reset. Reset will be activate on the falling edge of the signal.

DC braking, inverse is used for stopping the motor by energizing it with a DC voltage for a given time, see parameters 114-116 *DC brake*. Please note that this function is only active if the value of parameters 114 *DC brake current* and 115 *DC braking time* is different from 0. Logic '0' implements DC braking. See *DC braking* on page 86.

Safety interlock has the same function as *Coasting stop, inverse*, but *Safety interlock* generates the alarm message 'external fault' on the display when terminal 27 is logic '0'. The alarm message will also be active via digital outputs 42/45 and relay outputs 1/2, if programmed for *Safety interlock*. The alarm can be reset using a digital input or the [OFF/STOP] key.

Start is selected if a start/stop command is required. Logic '1' = start, logic '0' = stop.

Reversing is used for changing the direction of rotation of the motor shaft. Logic '0' will not implement reversing. Logic '1' will implement reversing.

The reversing signal only changes the direction of rotation; it does not activate the start function. Is not active together with *Closed loop*.

Reversing and start is used for start/stop and reversing using the same signal. A start signal via terminal 18 at the same time is not allowed. Is not active together with *Closed loop*.

DC braking is used to stop the motor by energizing it with a DC voltage for a given time, see parameters 114-116 *DC brake*. Please note that this function is only active if the value in parameter 114 *DC braking current* and 115 *DC braking time* is different from 0. Logic '1' implements DC braking. See *DC braking* on page 86.

Freeze reference freezes the present reference. The frozen reference can now only be changed by means of *Speed up* or *Speed down*. The frozen reference is saved after a stop command and in case of mains failure.

Freeze output freezes the present output frequency (in Hz). The frozen output frequency can now only be changed by means of *Speed up* or *Speed down*.

NB!



If *Freeze output* is active, the VLT frequency converter cannot be stopped via terminal 18. The VLT frequency converter can only be stopped when terminal 27 or terminal 19 has been programmed for *DC braking, inverse*.

Selection of Setup, lsb and **Selection of Setup, msb** enables a choice of one of the four Setups. However, this presupposes that parameter 002 *Active Setup* has been set at *Multi Setup* [5].

	Setup, msb	Setup, lsb
Setup 1	0	0
Setup 2	0	1
Setup 3	1	0
Setup 4	1	1

Preset reference, on is used for switching between remote reference and preset reference. This assumes that *Remote/preset* [2] has been selected in parameter 210 *Reference type*. Logic '0' = remote references active; logic '1' = one of the four preset references is active in accordance with the table below.

Preset reference, Isb and **Preset reference, msb** enables a choice of one of the four preset references, in accordance with the table below.

	Preset ref. msb	Preset ref. Isb
Preset ref. 1	0	0
Preset ref. 2	0	1
Preset ref. 3	1	0
Preset ref. 4	1	1

Speed up and Speed down are selected if digital control of the up/down speed is desired. This function is only active if *Freeze reference* or *Freeze output* has been selected.

As long as there is a logic '1' on the terminal selected for *Speed up*, the reference or the output frequency will increase by the *Ramp-up time* set in parameter 206.

As long as there is a logic '1' on the terminal selected for *Speed down*, the reference or the output frequency will increase by the *Ramp-down time* set in parameter 207.

Pulses (logic '1' minimum high for 3 ms and a minimum pause of 3 ms) will lead to a change of speed of 0.1% (reference) or 0.1 Hz (output frequency).

Example:

	Terminal (16)	Terminal (17)	Freeze ref./ Freeze output
No speed change	0	0	1
Speed down	0	1	1
Speed up	1	0	1
Speed down	1	1	1

The speed reference frozen via the control panel can be changed even if the VLT frequency converter has stopped. In addition, the frozen reference will be remembered in case of a mains failure.

Run permissive. There must be an active start signal via the terminal, where *Run permissive* has been programmed, before a start command can be accepted. *Run permissive* has a logic 'AND' function related to Start (terminal 18, parameter 302 *Terminal 18, Digital input*), which means that in order to start the motor, both conditions must be fulfilled. If *Run permissive* is programmed on several terminals, *Run permissive* must only be logic '1' on one of the terminals for the function to be carried out. See application example on page 68.

Jog is used to override the output frequency to the frequency set in parameter 209 *Jog frequency* and issue a start command. If local reference is active, the VLT frequency converter will always be in *Open loop* [0], regardless of the selection made in parameter 100 *Configuration*.

Jog is not active if a stop command has been given via terminal 27.

Data change lock is selected if data changes to parameters are not to be made via the control unit; however, it will still be possible to carry out data changes via the bus.

Pulse reference is selected if a pulse sequence (frequency) is selected as a reference signal. 0 Hz corresponds to Ref_{MIN} , parameter 204 *Minimum reference, Ref_{MIN}*.

The frequency set in parameter 327 *Pulse reference, max. frequency* corresponds to parameter 205 *Maximum reference, Ref_{MAX}*.

Pulse feedback is selected if a pulse sequence (frequency) is selected as a feedback signal. Parameter 328 *Pulse feedback, max. frequency* is where the maximum frequency for pulse feedback is set.

Hand start is selected if the VLT frequency converter is to be controlled by means of an external hand/off or H-O-A switch. A logic '1' (Hand start active) will mean that the VLT frequency converter starts the motor. A logic '0' means that the connected motor stops. The VLT frequency converter will then be in OFF/STOP mode, unless there is an active *Auto start signal*. See also the description on page 70.



NB!

An active *Hand* and *Auto* signal via the digital inputs will have higher priority than the [HAND START]-[AUTO START] control keys.

Auto start is selected if the VLT frequency converter is to be controlled via an external auto/off or H-O-A switch. A logic '1' will place the VLT frequency converter in auto mode allowing a start signal on the control terminals or the serial communication port. If *Auto start* and *Hand start* are active at the same time on the control terminals, *Auto start* will have the highest priority. If *Auto start* and *Hand start* are not active, the connected motor will stop and the VLT frequency converter will then be in OFF/STOP mode. See also the description on page 70.

■ **Analogue inputs**

Two analogue inputs for voltage signals (terminals 53 and 54) are provided for reference and feedback signals. Furthermore, an analogue input is available for a current signal (terminal 60). A thermistor can be connected to voltage input 53 or 54.

The two analogue voltage inputs can be scaled in the range of 0-10 V DC; the current input in the range of 0-20 mA.

The table below gives the possibilities for programming the analogue inputs.

Parameter 317 *Time out* and 318 *Function after time out* allow activation of a time-out function on all analogue inputs. If the signal value of the reference or feedback signal connected to one of the analogue input terminals drops to below 50% of the minimum scaling, a function will be activated after the time out determined in parameter 318, *Function after time out*.

Analogue inputs	terminal no.	53(voltage)	54(voltage)	60(current)
	parameter	308	311	314
Value:				
No operation	(NO OPERATION)	[0]	[0] ★	[0]
Reference	(REFERENCE)	[1] ★	[1]	[1] ★
Feedback	(FEEDBACK)	[2]	[2]	[2]
Thermistor	(THERMISTOR)	[3]	[3]	

308 Terminal 53, analogue input voltage (AI [V] 53 FUNCT.)

Function:

This parameter is used to select the required function to be linked to terminal 53.

Description of choice:

No operation. Is selected if the VLT frequency converter is not to react to signals connected to the terminal.

Reference. Is selected to enable change of reference by means of an analogue reference signal. If reference signals are connected to several inputs, these reference signals must be added up.

Feedback. If a feedback signal is connected, there is a choice of a voltage input (terminal 53 or 54) or a current input (terminal 60) as feedback. In the case of zone regulation, feedback signals must be selected as voltage inputs (terminals 53 and 54). See *Feedback handling* on page 115.

Thermistor. Is selected if a thermistor integrated in the motor is to be able to stop the VLT frequency converter in case of motor overtemperature. The cut-out value is 3 kohm.

If a motor features a Klaxon thermal switch instead, this can also be connected to the input. If motors run in parallel, the thermistors/thermal switches can be connected in series (total resistance < 3 kohm). Parameter 117 *Motor thermal protection* must be programmed for *Thermal warning* [1] or *Thermistor trip* [2], and the thermistor must be inserted between terminal 53 or 54 (analogue voltage input) and terminal 50 (+10 V supply).

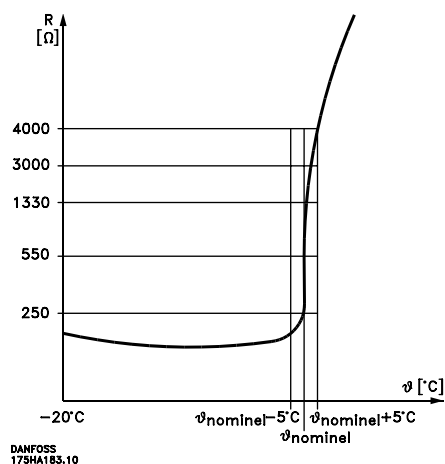

★ = factory setting. () = display text [] = value for use in communication via serial communication port

309 Terminal 53, min. scaling

(AI 53 SCALE LOW)

Value:

0.0 - 10.0 V ★ 0.0 V

Function:

This parameter is used for setting the signal value that has to correspond to the minimum reference or the minimum feedback, parameter 204 *Minimum reference*, Ref_{MIN} /413 *Minimum feedback*, FB_{MIN} . See *Reference handling* on page 89 or *Feedback handling* on page 115.

Description of choice:

Set the required voltage value.
For reasons of accuracy, voltage losses in long signal lines can be compensated for.
If the time-out function is to be applied (parameters 317 *Time out* and 318 *Function after time out*), the value must be set to > 1 V.

310 Terminal 53, max. scaling

(AI 53 SCALE HIGH)

Value:

0.0 - 10.0 V ★ 10.0 V

Function:

This parameter is used for setting the signal value that has to correspond to the maximum reference value or the maximum feedback, parameter 205 *Maksimum reference*, Ref_{MAX} /414 *Maximum feedback*, FB_{MAX} . See *Reference handling* on page 89 or *Feedback handling* on page 115.

Description of choice:

Set the required voltage value.
For reasons of accuracy, voltage losses in long signal lines can be compensated for.

311 Terminal 54, analogue input voltage

(AI [V] 54 FUNCT.)

Value:

See description of parameter 308. ★ No operation

Function:

This parameter chooses between the different functions available for the input, terminal 54.

Scaling of the input signal is effected in parameter 312 *Terminal 54, min. scaling* and in parameter 313 *Terminal 54, max. scaling*.

Description of choice:

See description of parameter 308.
For reasons of accuracy, voltage losses in long signal lines should be compensated for.

312 Terminal 54, min. scaling

(AI 54 SCALE LOW)

Value:

0.0 - 10.0 V ★ 0.0 V

Function:

This parameter is used for setting the signal value that corresponds to the minimum reference value or the minimum feedback, parameter 204 *Minimum reference*, Ref_{MIN} /413 *Minimum feedback*, FB_{MIN} . See *Reference handling* on page 89 or *Feedback handling* on page 115.

Description of choice:

Set the required voltage value.
For reasons of accuracy, voltage losses in long signal lines can be compensated for.
If the time-out function is to be applied (parameters 317 *Time out* and 318 *Function after time out*), the value must be set to > 1 V.

313 Terminal 54, max. scaling

(AI 54 SCALE HIGH)

Value:

0.0 - 10.0 V ★ 10.0 V

Function:

This parameter is used for setting the signal value that corresponds to the maximum reference value or the maximum feedback, parameter 205 *Maximum reference*, Ref_{MAX} /414 *Maximum feedback*, FB_{MAX} . See *Reference handling* on page 89 or *Feedback handling* on page 115.

Description of choice:

Set the required voltage value.
For reasons of accuracy, voltage losses in long signal lines can be compensated for.

**314 Terminal 60, analogue input current
(AI [mA] 60 FUNCT.)**
Value:

See description of parameter 308. ★ Reference

Function:

This parameter allows a choice between the different functions available for the input, terminal 60. Scaling of the input signal is effected in parameter 315 *Terminal 60, min. scaling* and in parameter 316 *Terminal 60, max. scaling*.

Description of choice:

 See description of parameter 308 *Terminal 53, analogue input voltage*.

**315 Terminal 60, min. scaling
(AI 60 SCALE LOW)**
Value:

0.0 - 20.0 mA ★ 4.0 mA

Function:

This parameter determines the signal value that corresponds to the minimum reference or the minimum feedback, parameter 204 *Minimum reference, Ref_{MIN}*/413 *Minimum feedback, FB_{MIN}*. See *Reference handling* on page 89 or *Feedback handling* on page 115.

Description of choice:

Set the required current value. If the time-out function is to be used (parameters 317 *Time out* and 318 *Function after time out*), the value must be set to > 2 mA.

**316 Terminal 60, max. scaling
(AI 60 SCALE HIGH)**
Value:

0.0 - 20.0 mA ★ 20.0 mA

Function:

This parameter determines the signal value that corresponds to the maximum reference value, parameter 205 *Maximum reference value, Ref_{MAX}*. See *Reference handling* on page 89 or *Feedback handling* on page 115.

Description of choice:

Set the desired current value.

**317 Time out
(LIVE ZERO TIME)**
Value:

1 - 99 sec. ★ 10 sec.

Function:

If the signal value of the reference or feedback signal connected to one of the input terminals 53, 54 or 60 drops to below 50% of the minimum scaling during a period longer than the preset time, the function selected in parameter 318 *Function after time out* will be activated.

This function will only be active if, in parameter 309 or 312, a value has been selected for *terminals 53 and 54, min. scaling* that exceeds 1 V, or if, in parameter 315 *Terminal 60, min. scaling*, a value has been selected that exceeds 2 mA.

Description of choice:

Set the desired time.

**318 Function after time out
(LIVE ZERO FUNCT.)**
Value:

- ★ Off (NO FUNCTION) [0]
- Freeze output frequency (FREEZE OUTPUT FREQ.) [1]
- Stop (STOP) [2]
- Jog (JOG FREQUENCY) [3]
- Max. output frequency (MAX FREQUENCY) [4]
- Stop and trip (STOP AND TRIP) [5]

Function:

This is where to select the function to be activated after the end of the time-out period (parameter 317 *Time out*).

If a time-out function occurs at the same time as a bus time-out function (parameter 556 *Bus time interval function*), the time-out function in parameter 318 will be activated.

Description of choice:

The output frequency of the VLT frequency converter can be:

- frozen at the present value [1]
- overruled to stop [2]
- overruled to jog frequency [3]
- overruled to max. output frequency [4]
- overruled to stop with subsequent trip [5].

★ = factory setting. () = display text [] = value for use in communication via serial communication port

■ Analogue/digital outputs

The two analogue/digital outputs (terminals 42 and 45) can be programmed to show the present status or a process value such as $0 - f_{MAX}$.

If the VLT frequency converter is used as a digital output, it gives the present status by means of 0 or 24 V DC.

If the analogue output is used for giving a process value, there is a choice of three types of output signal:

0-20 mA, 4-20 mA or 0-32000 pulses (depending on the value set in parameter 322 *Terminal 45, output, pulse scaling*).

If the output is used as a voltage output (0-10 V), a pull-down resistor of 470 Ω (max. 500 Ω) should be fitted to terminal 39 (common for analogue/digital outputs). If the output is used as a current output, the resulting impedance of the connected equipment should not exceed 500 Ω .

Analogue/digital outputs	terminal no.	42	45
	parameter	319	321
Value:			
No function (NO FUNCTION)		[0]	[0]
Drive ready (UN. READY)		[1]	[1]
Standby (STAND BY)		[2]	[2]
Running (RUNNING)		[3]	[3]
Running at ref. value (RUNNING AT REFERENCE)		[4]	[4]
Running, no warning (RUNNING NO WARNING)		[5]	[5]
Local reference active (DRIVE IN LOCAL REF.)		[6]	[6]
Remote references active (DRIVE IN REMOTE REF.)		[7]	[7]
Alarm (ALARM)		[8]	[8]
Alarm or warning (ALARM OR WARNING)		[9]	[9]
No alarm (NO ALARM)		[10]	[10]
Current limit (CURRENT LIMIT)		[11]	[11]
Safety interlock (SAFETY INTERLOCK)		[12]	[12]
Start command active (START SIGNAL APPLIED)		[13]	[13]
Reversing (RUNNING IN REVERSE)		[14]	[14]
Thermal warning (THERMAL WARNING)		[15]	[15]
Hand mode active (DRIVE IN HAND MODE)		[16]	[16]
Auto mode active (DRIVE IN AUTO MODE)		[17]	[17]
Sleep mode (SLEEP MODE)		[18]	[18]
Output frequency lower than f_{LOW} parameter 223 (F OUT < F LOW)		[19]	[19]
Output frequency higher than f_{HIGH} parameter 223 (F OUT > F HIGH)		[20]	[20]
Out of frequency range (FREQ. RANGE WARN.)		[21]	[21]
Output current lower than I_{LOW} parameter 221 (I OUT < I LOW)		[22]	[22]
Output current higher than I_{HIGH} parameter 222 (I OUT > I HIGH)		[23]	[23]
Out of current range (CURRENT RANGE WARN)		[24]	[24]
Out of feedback range (FEEDBACK RANGE WARN.)		[25]	[25]
Out of reference range (REFERENCE RANGE WARN)		[26]	[26]
Relay 123 (RELAY 123)		[27]	[27]
Mains failure (MAINS PHASE LOSS)		[28]	[28]
Output frequency, $0 - f_{MAX} \Rightarrow 0-20$ mA (OUT. FREQ. 0-20 mA)		[29]	★ [29]
Output frequency, $0 - f_{MAX} \Rightarrow 4-20$ mA (OUT. FREQ. 4-20 mA)		[30]	[30]
Output frequency (pulse sequence), $0 - f_{MAX} \Rightarrow 0-32000$ p (OUT. FREQ. PULSE)		[31]	[31]
External reference, $Ref_{MIN} - Ref_{MAX} \Rightarrow 0-20$ mA (EXT. REF. 0-20 mA)		[32]	[32]
External reference, $Ref_{MIN} - Ref_{MAX} \Rightarrow 4-20$ mA (EXTERNAL REF. 4-20 mA)		[33]	[33]
External reference (pulse sequence), $Ref_{MIN} - Ref_{MAX} \Rightarrow 0-32000$ p (EXTERNAL REF. PULSE)		[34]	[34]
Feedback, $FB_{MIN} - FB_{MAX} \Rightarrow 0-20$ mA (FEEDBACK 0-20 mA)		[35]	[35]
Feedback, $FB_{MIN} - FB_{MAX} \Rightarrow 4-20$ mA (FEEDBACK 4-20 mA)		[36]	[36]
Feedback (pulse sequence), $FB_{MIN} - FB_{MAX} \Rightarrow 0 - 32000$ p (FEEDBACK PULSE)		[37]	[37]
Output current, $0 - I_{MAX} \Rightarrow 0-20$ mA (MOTOR CUR. 0- 20 mA)		★ [38]	[38]
Output current, $0 - I_{MAX} \Rightarrow 4-20$ mA (MOTOR CUR. 4- 20 mA)		[39]	[39]
Output current (pulse sequence), $0 - I_{MAX} \Rightarrow 0 - 32000$ p (MOTOR CUR. PULSE)		[40]	[40]
Output power, $0 - P_{NOM} \Rightarrow 0-20$ mA (MOTOR POWER 0-20 mA)		[41]	[41]
Output power, $0 - P_{NOM} \Rightarrow 4-20$ mA (MOTOR POWER 4-20 mA)		[42]	[42]
Output power (pulse sequence), $0 - P_{NOM} \Rightarrow 0- 32000$ p (MOTOR POWER PULSE)		[43]	[43]

★ = factory setting. () = display text [] = value for use in communication via serial communication port

Function:

This output can act both as a digital or an analogue output. If used as a digital output (data value [0]-[59]), a 0/24 V DC signal is transmitted; if used as an analogue output, either a 0-20 mA signal, a 4-20 mA signal or a pulse sequence of 0-32000 pulses is transmitted.

Description of choice:

No function. Selected if the VLT frequency converter is not to react to signals.

Drive ready. The VLT frequency converter control card receives a supply voltage and the frequency converter is ready for operation.

Stand by. The VLT frequency converter is ready for operation, but no start command has been given. No warning.

Running. A start command has been given.

Running at ref. value. Speed according to reference.

Running, no warning. A start command has been given. No warning.

Local reference active. The output is active when the motor is controlled by means of the local reference via the control unit.

Remote references active. The output is active when the VLT frequency converter is controlled by means of the remote references.

Alarm. The output is activated by an alarm.

Alarm or warning. The output is activated by an alarm or a warning.

No alarm. The output is active when there is no alarm.

Current limit. The output current is greater than the value programmed in parameter 215 *Current limit* I_{LIM} .

Safety interlock. The output is active when terminal 27 is a logic '1' and *Safety interlock* has been selected on the input.

Start command active. Is active when there is a start command.

Reversing. There is 24 V DC on the output when the motor rotates anti-clockwise. When the motor rotates clockwise, the value is 0 V DC.

Thermal warning. The temperature limit in either the motor, the VLT frequency converter or a thermistor connected to an analogue input has been exceeded.

Hand mode active. The output is active when the VLT frequency converter is in Hand mode.

Auto mode active. The output is active when the VLT frequency converter is in Auto mode.

Sleep mode. Active when the VLT frequency converter is in Sleep mode.

Output frequency lower than f_{LOW} . The output frequency is lower than the value set in parameter 223 *Warning: Low frequency, f_{LOW} .*

Output frequency higher than f_{HIGH} . The output frequency is higher than the value set in parameter 224 *Warning: High frequency, f_{HIGH} .*

Out of frequency range. The output frequency is outside the frequency range programmed in parameter 223 *Warning: Low frequency, f_{LOW} and 224 *Warning: High frequency, f_{HIGH} .**

Output current lower than I_{LOW} . The output current is lower than the value set in parameter 221 *Warning: Low current, I_{LOW} .*

Output current higher than I_{HIGH} . The output current is higher than the value set in parameter 222 *Warning: High current, I_{HIGH} .*

Out of current range. The output current is outside the range programmed in parameter 221 *Warning: Low current, I_{LOW} and 222 *Warning, High current, I_{HIGH} .**

Out of feedback range. The feedback signal is outside the range programmed in parameter 227 *Warning: Low feedback, FB_{LOW}* and 228 *Warning: High feedback, FB_{HIGH} .*

Out of reference range. The reference lies outside the range programmed in parameter 225 *Warning: Low reference, Ref_{LOW}* and 226 *Warning: High reference, Ref_{HIGH} .*

Relay 123. This function is only used when a profibus option card is installed.

Mains fault. This output is activated when a phase is missing in the mains supply. Check the mains voltage to the VLT frequency converter.

$0-f_{MAX} \Rightarrow 0-20\text{ mA}$ and
 $0-f_{MAX} \Rightarrow 4-20\text{ mA}$ and
 $0-f_{MAX} \Rightarrow 0-32000\text{ p}$, which generates an output signal proportional to the output frequency in the interval 0 - f_{MAX} (parameter 202 *Output frequency, high limit, f_{MAX}*).

External $Ref_{MIN} - Ref_{MAX} \Rightarrow 0-20\text{ mA}$ and
External $Ref_{MIN} - Ref_{MAX} \Rightarrow 4-20\text{ mA}$ and
External $Ref_{MIN} - Ref_{MAX} \Rightarrow 0-32000\text{ p}$, which generates an output signal proportional to the resulting reference value in the interval *Minimum reference, Ref_{MIN} - Maximum reference, Ref_{MAX}* (parameters 204/205).

$FB_{MIN}-FB_{MAX} \Rightarrow 0-20\text{ mA}$ and
 $FB_{MIN}-FB_{MAX} \Rightarrow 4-20\text{ mA}$ and
 $FB_{MIN}-FB_{MAX} \Rightarrow 0-32000\text{ p}$, an output signal proportional to the reference value in the interval *Minimum feedback, FB_{MIN} - Maximum feedback, FB_{MAX}* (parameters 413/414) is obtained.

$0 - I_{VLT, MAX} \Rightarrow 0-20\text{ mA}$ and
 $0 - I_{VLT, MAX} \Rightarrow 4-20\text{ mA}$ and
 $0 - I_{VLT, MAX} \Rightarrow 0-32000\text{ p}$, an output signal proportional to the output current in the interval 0 - $I_{VLT,MAX}$ is obtained.

$0 - P_{NOM} \Rightarrow 0-20\text{ mA}$ and
 $0 - P_{NOM} \Rightarrow 4-20\text{ mA}$ and
 $0 - P_{NOM} \Rightarrow 0-32000\text{ p}$, which generates an output signal proportional to the present output power. 20 mA corresponds to the value set in parameter 102 *Motor power, $P_{M,N}$.*

320 Terminal 42, output, pulse scaling (AO 42 PULS SCALE)

Value:
 1 - 32000 Hz ★ 5000 Hz

Function:
 This parameter allows scaling of the pulse output signal.

Description of choice:
 Set the desired value.

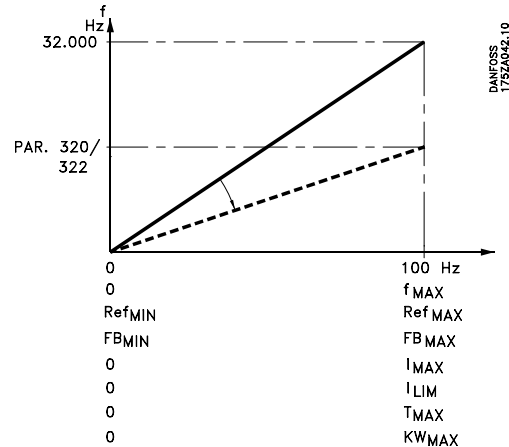

321 Terminal 45, output (AO 45 FUNCTION)

Value:
 See description of parameter 319 *Terminal 42, Output*.

Function:
 This output can function both as a digital or an analogue output. When used as a digital output (data value [0]-[26]) it generates a 24 V (max. 40 mA) signal. For the analogue outputs (data value [27] - [41]) there is a choice of 0-20 mA, 4-20 mA or a pulse sequence.

Description of choice:
 See description of parameter 319 *Terminal 42, Output*.

322 Terminal 45, output, pulse scaling (AO 45 PULS SCALE)

Value:
 1 - 32000 Hz ★ 5000 Hz

Function:
 This parameter allows scaling of the pulse output signal.

Description of choice:
 Set the desired value.

★ = factory setting. () = display text [] = value for use in communication via serial communication port

■ **Relay outputs**

Relay outputs 1 and 2 can be used to give the present status or a warning.

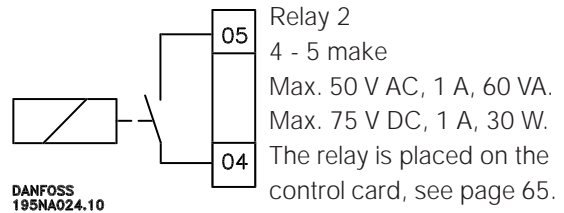
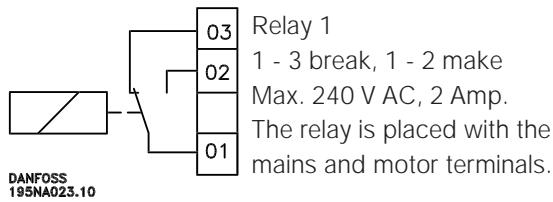

Relay outputs	Relay no. parameter	1 323	2 326
Value:			
No function (NO FUNCTION)		[0]	[0]
Ready signal (READY)		[1]	[1]
Standby (STAND BY)		[2]	[2]
Running (RUNNING)		[3]	★ [3]
Running at ref. value (RUNNING AT REFERENCE)		[4]	[4]
Running, no warning (RUNNING NO WARNING)		[5]	[5]
Local reference active (DRIVE IN LOCAL REF)		[6]	[6]
Remote references active (DRIVE IN REMOTE REF.)		[7]	[7]
Alarm (ALARM)		★ [8]	[8]
Alarm or warning (ALARM OR WARNING)		[9]	[9]
No alarm (NO ALARM)		[10]	[10]
Current limit (CURRENT LIMIT)		[11]	[11]
Safety interlock (SAFETY INTERLOCK)		[12]	[12]
Start command active (START SIGNAL APPLIED)		[13]	[13]
Reversing (RUNNING IN REVERSE)		[14]	[14]
Thermal warning (THERMAL WARNING)		[15]	[15]
Hand mode active (DRIVE IN HAND MODE)		[16]	[16]
Auto mode active (DRIVE IN AUTO MODE)		[17]	[17]
Sleep mode (SLEEP MODE)		[18]	[18]
Output frequency lower than f_{LOW} parameter 223 (F OUT < F LOW)		[19]	[19]
Output frequency higher than f_{HIGH} parameter 224 (F OUT > F HIGH)		[20]	[20]
Out of frequency range (FREQ RANGE WARN.)		[21]	[21]
Output current lower than I_{LOW} parameter 221 (I OUT < I LOW)		[22]	[22]
Output current higher than I_{HIGH} parameter 222 (I OUT > I HIGH)		[23]	[23]
Out of current range (CURRENT RANGE WARN.)		[24]	[24]
Out of feedback range (FEEDBACK RANGE WARN.)		[25]	[25]
Out of reference range (REFERENCE RANGE WARN.)		[26]	[26]
Relay 123 (RELAY 123)		[27]	[27]
Mains fault (MAINS PHASE LOSS)		[28]	[28]
Control word 11/12 (CONTROL WORD 11/12)		[29]	[29]

Description of choice:

See description of [0] - [28] on page 104.

Control word bit 11/12, relay 1 and relay 2 can be activated via the serial communication. Bit 11 activates relay 1 and bit 12 activates relay 2.

If the parameter 556 *Bus time interval function* becomes active, relay 1 and relay 2 will become cut off if they are activated via the serial communication. See paragraph *Serial communication* in Design Guide.

★ = factory setting. () = display text [] = value for use in communication via serial communication port

**323 Relay 1, output function
(RELAY1 FUNCTION)**
Function:

This output activates a relay switch. Relay switch 01 can be used for bringing status and warnings. The relay is activated when the conditions for the relevant data values have been fulfilled. Activation/deactivation can be programmed in parameter 324 *Relay 1, ON delay* and parameter 325 *Relay 1, OFF delay*. See technical data page 43.

Description of choice:

See data choice and connections on page 106.

**324 Relay 01, ON delay
(RELAY1 ON DELAY)**
Value:

0 - 600 sec. ★ 0 sec.

Function:

This parameter allows a delay of the cut-in time of relay 1 (terminals 1-2).

Description of choice:

Enter the desired value.

**325 Relay 01, OFF delay
(RELAY1 OFF DELAY)**
Value:

0 - 600 sec. ★ 0 sec.

Function:

This parameter makes it possible to delay the cut-out time of relay 01 (terminals 1-2).

Description of choice:

Enter the desired value.

**326 Relay 2, output function
(RELAY2 FUNCTION)**
Value:

See functions of relay 2 on previous page.

Function:

This output activates a relay switch. Relay switch 2 can be used for bringing status and warnings. The relay is activated when the conditions for the relevant data values have been fulfilled. See technical data, page 43.

Description of choice:

See data choice and connections on page 106.

**327 Pulse reference, max. frequency
(PULSE REF. MAX)**
Value:

100 - 65000 Hz at terminal 29 ★ 5000 Hz
100 - 5000 Hz at terminal 17

Function:

This parameter is used to set the pulse value that must correspond to the maximum reference, parameter 205 *Maximum reference, Ref_{MAX}*. The pulse reference signal can be connected via terminal 17 or 29.

Description of choice:

Set the required maximum pulse reference.

**328 Pulse feedback, max. frequency
(PULSE FDBK MAX.)**
Value:

100 - 65000 Hz at terminal 33 ★ 25000 Hz

Function:

This is where the pulse value that must correspond to the maximum feedback value is set. The pulse feedback signal is connected via terminal 33.

Description of choice:

Set the desired feedback value.

★ = factory setting. () = display text [] = value for use in communication via serial communication port

■ Application functions 400-427

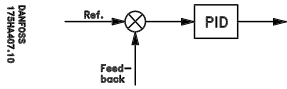

In this parameter group, the special functions of the VLT frequency converter are set up, e.g. PID regulation, setting of

the feedback range and the Setup of the Sleep mode function.

Additionally, this parameter group includes:

- Reset function.
- Flying start.
- Option of interference reduction method.
- Setup of any function upon loss of load, e.g. because of a damaged V-belt.
- Setting of switching frequency.
- Selection of process units.

400 Reset function (RESET FUNCTION)

Value:

- ★ Manual reset (MANUAL RESET) [0]
- Automatic reset x 1 (AUTOMATIC X 1) [1]
- Automatic reset x 2 (AUTOMATIC X 2) [2]
- Automatic reset x 3 (AUTOMATIC X 3) [3]
- Automatic reset x 4 (AUTOMATIC X 4) [4]
- Automatic reset x 5 (AUTOMATIC X 5) [5]
- Automatic reset x 10 (AUTOMATIC X 10) [6]
- Automatic reset x 15 (AUTOMATIC X 15) [7]
- Automatic reset x 20 (AUTOMATIC X 20) [8]

Function:

This parameter allows a choice of whether to reset and restart manually after a trip, or whether the VLT frequency converter is to be reset and restarted automatically. In addition, there is a choice of the number of times the unit is to try a restart. The time between each try is set in parameter 401 *Automatic restart time*.

Description of choice:

If *Manual reset* [0] is selected, resetting must be effected via the "Reset" key or via a digital input. If the VLT frequency converter is to carry out an automatic reset and restart after a trip, select data value [1]-[8].



The motor may start without warning.

401 Automatic restart time (AUTORESTART TIME)

Value:

- 0 - 600 sec. ★ 10 sec.

Function:

This parameter allows setting of the time from tripping until the automatic reset function begins.

It is assumed that automatic reset has been selected in parameter 400 *Reset function*.

Description of choice:

Set the desired time.

402 Flying start (FLYING START)

(FLYING START)

Value:

- Disable (DISABLE) [0]
- ★ Enable (ENABLE) [1]
- DC brake and start (DC BRAKE AND START) [3]

Function:

This function makes it possible for the VLT frequency converter to 'catch' a spinning motor, which - e.g. because of a mains failure - is no longer controlled by the VLT frequency converter.

This function is activated whenever a start command is active.

For the VLT frequency converter to be able to catch the spinning motor, the motor speed must be lower than the frequency that corresponds to the frequency in parameter 202 *Output frequency high limit, f_{MAX}*.

Description of choice:

Select *Disable* [0] if this function is not required. Select *Enable* [1] if the VLT frequency converter is to be able to 'catch' and control a spinning motor. Select *DC brake and start* [2] if the VLT frequency converter is to brake the motor by means of the DC brake first, and then start. It is assumed that parameters 114-116 *DC braking* are enabled. In the case of a substantial 'windmilling' effect (spinning motor), the VLT frequency converter is not able to 'catch' a spinning motor unless *DC brake and start* has been selected.

★ = factory setting. () = display text [] = value for use in communication via serial communication port

■ Sleep mode

Sleep mode makes it possible to stop the motor when it is running at low speed and thus has almost no load. If consumption in the system goes back up, the VLT frequency converter will start the motor and supply the power required.



NB!

Energy can be saved with this function, since the motor is only in operation when the system needs it.

Sleep mode is not active if *Local reference* or *Jog* has been selected

The function is active in both *Open loop* and *Closed loop*.

In parameter 403 *Sleep mode timer*, the Sleep mode is activated. In parameter 403 *Sleep mode timer*, a timer is set that determines for how long the output frequency can be lower than the frequency set in parameter 404 *Sleep frequency*. When the timer runs out, the VLT frequency converter will ramp down the motor to stop via parameter 207 *Ramp-down time*. If the output frequency rises above the frequency set in parameter 404 *Sleep frequency*, the timer is reset.

While the VLT frequency converter has stopped the motor in sleep mode, a theoretical output frequency is calculated on the basis of the reference signal. When the theoretical output frequency rises above the frequency in parameter 405 *Wake up frequency*, the VLT frequency converter will restart the motor and the output frequency will ramp up to the reference.

In systems with constant pressure regulation, it is advantageous to provide extra pressure to the system before the VLT frequency converter stops the motor. This extends the time during which the VLT frequency converter has stopped the motor and helps to avoid frequent starting and stopping of the motor, e.g. in the case of system leaks.

If 25% more pressure is required before the VLT frequency converter stops the motor, parameter 406 *Boost setpoint* is set to 125%.

Parameter 406 *Boost setpoint* is only active in *Closed loop*.

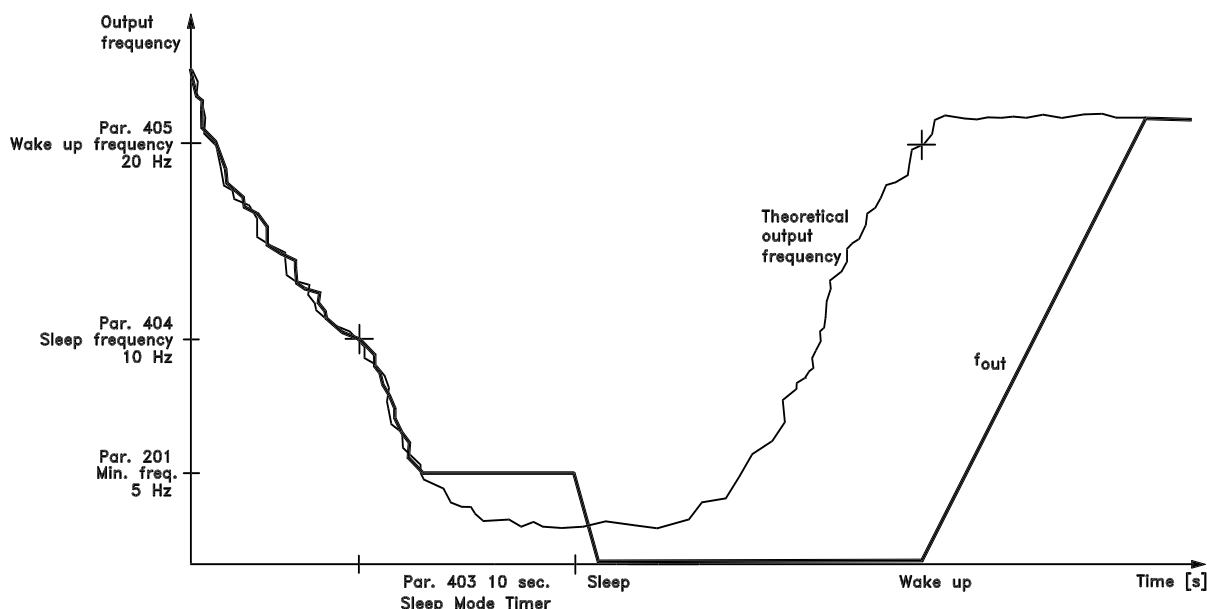

DANFOSS
175H348.14

★ = factory setting. () = display text [] = value for use in communication via serial communication port

**403 Sleep mode timer
(SLEEP MODE TIMER)**

Value:
0 - 300 sec.(OFF) ★ OFF

Function:

This parameter enables the VLT frequency converter to stop the motor if the load on the motor is minimal. The timer in parameter 403 *Sleep mode timer* starts when the output frequency drops below the frequency set in parameter 404 *Sleep frequency*. When the time set in the timer has expired, the VLT frequency converter will turn off the motor. The VLT frequency converter will restart the motor, when the theoretical output frequency exceeds the frequency in parameter 405 *Wake up frequency*.

Description of choice:

Select OFF if this function is not wanted. Set the threshold value that is to activate Sleep mode after the output frequency has fallen below parameter 404 *Sleep frequency*.

404 Sleep frequency (SLEEP FREQUENCY)

Value:
000,0 - par. 405 *Wake up frequency* ★ 0.0 Hz

Function:

When the output frequency falls below the preset value, the timer will start the time count set in parameter 403 *Sleep mode*. The present output frequency will follow the theoretical output frequency until f_{MIN} is reached.

Description of choice:

Set the required frequency.

405 Wake up frequency (WAKEUP FREQUENCY)

Value:
Par 404 *Sleep frequency* - par. 202 f_{MAX} ★ 50 Hz

Function:

When the theoretical output frequency exceeds the preset value, the VLT frequency converter restarts the motor.

Description of choice:

Set the required frequency.

406 Boost setpoint (BOOST SETPOINT)

Value:
0 - 200 % ★ 100 % of setpoint

Function:

This function can only be used if *Closed loop* has been selected in parameter 100. In systems with constant pressure regulation, it is advantageous to increase the pressure in the system before the VLT frequency converter stops the motor. This extends the time during which the VLT frequency converter stops the motor and helps to avoid frequent starting and stopping of the motor, e.g. in the case of leaks in the water supply system.

Description of choice:

Set the required *Boost setpoint* as a percentage of the resulting reference under normal operation. 100% corresponds to the reference without boost (supplement).

**407 Switching frequency
(SWITCHING FREQ.)**

Value:
Depends on the size of the unit.

Function:

The preset value determines the switching frequency of the inverter, provided *Fixed switching frequency* [1] has been selected in parameter 408 *Interference reduction method*. If the switching frequency is changed, this may help to minimise possible acoustic noise from the motor.

NB!

The output frequency of the VLT frequency converter can never assume a value higher than 1/10 of the switching frequency.

Description of choice:

When the motor is running, the switching frequency is adjusted in parameter 407 *Switching frequency*, until the frequency has been achieved at which the motor is as quiet as possible.

NB!

Switching frequencies higher than 4.5 kHz implement automatic derating of the maximum output of the VLT frequency converter. See *Derating of high switching frequency* on page 112.

408 Interference reduction method
(NOISE REDUCTION)

Value:

- ★ ASFM (ASFM) [0]
Fixed switching frequency
(FIXED SWITCHING FREQ.) [1]
- LC filter fitted (LC-FILTER CONNECTED) [2]

Function:

Used to select different methods for reducing the amount of acoustic interference from the motor.

Description of choice:

ASFM [0] guarantees that the maximum switching frequency is used at all times without derating of the VLT frequency converter. This is done by monitoring the load.

Fixed switching frequency [1] makes it possible to set a fixed high/low switching frequency. This can generate the best result, as the switching frequency can be set to lie outside the motor interference or in a less irritating area. The switching frequency is adjusted in parameter 407 *Switching frequency*. *LC-filter fitted* [2] is to be used if an LC-filter is fitted between the VLT frequency converter and the motor, as the VLT frequency converter will otherwise not be able to protect the LC-filter.

409 Function in case of no load
(FUNCT. LOW CURR.)

Value:

- Trip (TRIP) [0]
- ★ Warning (WARNING) [1]

Function:

This parameter can be used e.g. for monitoring the V-belt of a fan to make sure it has not snapped. This function is activated when the output current goes below parameter 221 *Warning: Low current*.

Description of choice:

In the case of a *Trip* [1], the VLT frequency converter will stop the motor.

If *Warning* [2] is selected, the VLT frequency converter will give a warning if the output current drops below the threshold value in parameter 221 *Warning: Low current*, I_{LOW} .

412 Trip delay overcurrent, I_{LIM}
(OVERLOAD DELAY)

Value:

- 0 - 60 sec. (61=OFF) ★ 60 sec.

Function:

When the frequency converter registers that the output current has reached the current limit I_{LIM} (parameter 215 *Current limit*) and stays there for the duration selected, a cut-out will be performed.

Description of choice:

Select for how long the frequency converter is to be able to keep up with the output current at the current limit I_{LIM} before it cuts out.

In OFF mode, parameter 412 *Trip delay overcurrent*, I_{LIM} is inactive, i.e. cut-outs are not performed.

Feedback signals in open loop

Normally, feedback signals and thus feedback parameters are only used in *Closed loop* operation; in VLT 6000 HVAC units, however, the feedback parameters are also active in *Open loop* operation. In *Open loop mode*, the feedback parameters can be used to show a process value in the display. If the present temperature is to be displayed, the temperature range can be scaled in parameters 413/414 *Minimum/Maximum feedback*, and the unit (°C, °F) in parameter 415 *Process units*.

**413 Minimum feedback, FB_{MIN}
(MIN. FEEDBACK)**
Value:
 $-999,999.999 - FB_{MAX}$ ★ 0.000

Function:

Parameters 413 *Minimum feedback*, FB_{MIN} and 414 *Maximum feedback*, FB_{MAX} are used to scale the display indication, thereby ensuring that it shows the feedback signal in a process unit proportionally to the signal at the input.

Description of choice:

Set the value to be shown on the display at minimum feedback signal value (par. 309, 312, 315 *Min. scaling*) on the selected feedback input (parameters 308/311/314 *Analogue inputs*).

**414 Maximum feedback, FB_{MAX}
(MAX. FEEDBACK)**
Value:
 $FB_{MIN} - 999,999.999$ ★ 100.000

Function:

See the description of par. 413 *Minimum feedback*, FB_{MIN} .

Description of choice:

Set the value to be shown on the display when maximum feedback (par. 310, 313, 316 *Max. scaling*) has been achieved at the selected feedback input (parameters 308/311/314 *Analogue inputs*).

**415 Units relating to closed loop
(REF. / FDBK. UNIT)**
Value:

No unit	[0]	°C	[21]
★%	[1]	GPM	[22]
rpm	[2]	gal/s	[23]
ppm	[3]	gal/min	[24]
pulse/s	[4]	gal/h	[25]
l/s	[5]	lb/s	[26]
l/min	[6]	lb/min	[27]
l/h	[7]	lb/h	[28]
kg/s	[8]	CFM	[29]
kg/min	[9]	ft ³ /s	[30]
kg/h	[10]	ft ³ /min	[31]
m ³ /s	[11]	ft ³ /h	[32]
m ³ /min	[12]	ft/s	[33]
m ³ /h	[13]	in wg	[34]
m/s	[14]	ft wg	[35]
mbar	[15]	PSI	[36]
bar	[16]	lb/in ²	[37]
Pa	[17]	HP	[38]
kPa	[18]	°F	[39]
mVS	[19]		
kW	[20]		

Function:

Selection of unit to be shown on the display. This unit will be used if *Reference [unit]* [2] or *Feedback [unit]* [3] has been selected in one of the parameters 007-010, as well as in the Display mode. In *Closed loop*, the unit is also used as a unit for *Minimum/Maximum reference* and *Minimum/Maximum feedback*, as well as *Setpoint 1* and *Setpoint 2*.

Description of choice:

Select the required unit for the reference/feedback signal.

■ **PID for process control**

The PID controller maintains a constant process condition (pressure, temperature, flow, etc.) and adjusts motor speed on the basis of a reference/setpoint and the feedback signal.

A transmitter supplies the PID controller with a feedback signal from the process to indicate its actual state. The feedback signal varies with the process load.

This means that deviations occur between the reference/setpoint and the actual process state. Such deviations are evened out by the PID regulator, in that it regulates the output frequency up or down in relation to the deviation between the reference/setpoint and the feedback signal.

The integral PID regulator in VLT 6000 HVAC units has been optimised for use in HVAC applications.

This means that a number of specialised functions are available in VLT 6000 HVAC units.

Formerly, it was necessary to get a BMS (Building Management System) to handle these special functions by installing extra I/O modules and by programming the system.

Using the VLT 6000 HVAC, there is no need for extra modules to be installed. For example, only one required reference/setpoint and the handling of feedback need to be programmed.

There is in-built a option for connecting two feedback signals to the system, making two-zone regulation possible.

Correction for voltage losses in long signal cables can be carried out when using a transmitter with a voltage output. This is done in parameter group 300 *Min./Max. scaling*.

Feedback

The feedback signal must be connected to a terminal on the VLT frequency converter. Use the list below to decide which terminal to use and which parameters to program.

<u>Feedback type</u>	<u>Terminal</u>	<u>Parameters</u>
Pulse	33	307
Voltage	53, 54	308, 309, 310 or 311, 312, 313
Current	60	314, 315, 316
Bus feedback 1	68+69	535
Bus feedback 2	68+69	536

Please note that the feedback value in parameter 535/536 Bus feedback 1 and 2 can only be set via serial communication (not via the control unit).

Furthermore, the minimum and maximum feedback (parameters 413 and 414) must be set to a value in the process unit that corresponds to the minimum and maximum scaling value for signals connected to the terminal. The process unit is selected in parameter 415 *Process units*.

Reference

In parameter 205 *Maximum reference*, Ref_{MAX} , a maximum reference that scales the sum of all references, i.e. the resulting reference, can be set. The *minimum reference* in parameter 204 indicates the smallest value that the resulting reference can assume.

The reference range cannot exceed the feedback range.

If *Preset references* are required, set these in parameters 211 to 214 *Preset reference*. See *Reference type* on page 92.

See also *Reference handling* on page 89.

If a current signal is used as a feedback signal, voltage can be used as analogue reference. Use the list below to decide which terminal to use and which parameters to program.

<u>Reference type</u>	<u>Terminal</u>	<u>Parameters</u>
Pulse	17 or 29	301 or 305
Voltage	53 or 54	308, 309, 310 or 311, 312, 313
Current	60	314, 315, 316
Preset reference		211, 212, 213, 214
Setpoints		418, 419
Bus reference	68+69	

Please note that the bus reference can only be set via serial communication.



NB!

Terminals that are not in use may preferably be set to *No function* [0].

★ = factory setting. () = display text [] = value for use in communication via serial communication port

■ PID for process regulation, cont.
Inverse regulation

Normal regulation means that the motor speed increases when the reference/setpoint is higher than the feedback signal. If there is a need for inverse regulation, in which the speed is reduced when the feedback signal is lower than the reference/setpoint, Inverse must be programmed in parameter 420 *PID normal/inverse control*.

Anti Windup

The process regulator is factory preset with an active anti-windup function. This function ensures that when either a frequency limit, current limit or voltage limit is reached, the integrator will be initialised for a frequency that corresponds to the present output frequency. This avoids integration on a deviation between the reference/setpoint and the actual state of the process, the controller of which is not possible by means of a speed change. This function can be disabled in parameter 421 *PID anti windup*.

Start-up conditions

In some applications, optimum setting of the process regulator will mean that it takes an excessive time for the required process state to be reached. In such applications it might be an advantage to fix an output frequency to which the VLT frequency converter is to bring the motor before the process regulator is activated. This is done by programming a *PID start-up frequency* in parameter 422.

Differentiator gain limit

If there are very quick variations in a given application with respect to the reference/setpoint signal or the feedback signal, the deviation between reference/setpoint and the actual process state will quickly change. The differentiator may thus become too dominant. This is because it reacts to the deviation between the reference/setpoint and the actual process state. The quicker the deviation changes, the stronger the resulting differentiator frequency contribution. The differentiator frequency contribution can thus be limited to allow the setting of a reasonable differentiation time for slow changes and a suitable frequency contribution for quick changes. This is done in parameter 426, *PID Differentiator gain limit*.

Lowpass filter

If there are ripple currents/voltages on the feedback signal, these can be dampened by means of a built-in lowpass filter. Set a suitable lowpass filter time constant. This time constant represents the limit frequency of the ripples occurring on the feedback signal.

If the lowpass filter has been set to 0.1s, the limit frequency will be 10 RAD/sec., corresponding to $(10/2 \times \pi) = 1.6$ Hz. This means that all currents/voltages that vary by more than 1.6 oscillations per second will be removed by the filter.

In other words, regulation will only be carried out on a feedback signal that varies by a frequency of less than 1.6 Hz. Choose a suitable time constant in parameter 427, *PID Lowpass filter time*.

Optimisation of the process regulator

The basic settings have now been made; all that remains to be done is to optimise the proportional gain, the integration time and the differentiation time (parameters 423, 424 and 425). In most processes, this can be done by following the guidelines given below.

1. Start the motor.
2. Set parameter 423 *PID proportional gain* to 0.3 and increase it until the process shows that the feedback signal is unstable. Then reduce the value until the feedback signal has stabilised. Now lower the proportional gain by 40-60%.
3. Set parameter 424 *PID integration time* to 20 s and reduce the value until the process shows that the feedback signal is unstable. Increase the integration time until the feedback signal stabilises, followed by an increase of 15-50%.
4. Parameter 425 *PID differentiation time* is only used in very fast-acting systems. The typical value is four times the value set in parameter 424 *PID Integration time*. The differentiator should only be used when the setting of the proportional gain and the integration time have been fully optimised.

NB!

If necessary, start/stop can be activated a number of times in order to provoke an unstable feedback signal.

■ **PID overview**

The block diagram below shows reference and setpoint in relation to the feedback signal.

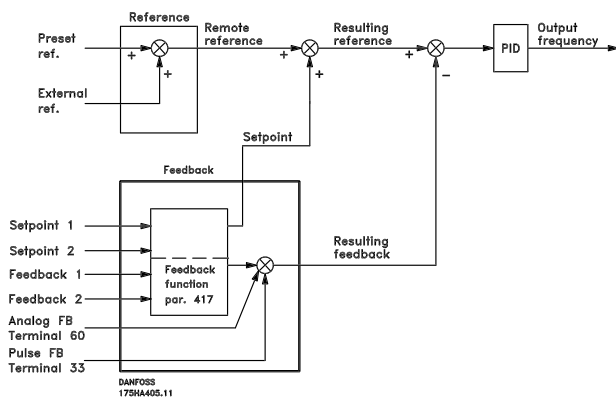

As can be seen, the remote reference is totalled with setpoint 1 or setpoint 2. See also *Reference handling* on page 61.

Which setpoint is to be totalled with the remote reference depends on the selection made in parameter 417 *Feedback function*.

■ **Feedback handling**

The feedback handling can be seen from the block diagram on the next page.

The block diagram shows how and by which parameters the feedback handling can be affected. Options as feedback signals are: voltage, current, pulse and bus feedback signals. In zone regulation, feedback signals must be selected as voltage inputs (terminals 53 and 54). Please note that *Feedback 1* consists of bus feedback 1 (parameter 535) totalled with the feedback signal value of terminal 53. *Feedback 2* consists of bus feedback 2 (parameter 536) totalled with the feedback signal value of terminal 54.

In addition, the VLT 6000 HVAC has an integral calculator capable of converting a pressure signal into a "linear flow" feedback signal. This function is activated in parameter 416 *Feedback conversion*.

The parameters for feedback handling are active both in closed and open loop modes. In *open loop*, the present temperature can be displayed by connecting a temperature transmitter to a feedback input.

In a closed loop, there are - roughly speaking - three possibilities of using the integral PID regulator and setpoint/feedback handling:

1. 1 setpoint and 1 feedback
2. 1 setpoint and 2 feedbacks
3. 2 Setpoints and 2 feedbacks

1 setpoint and 1 feedback

If only 1 setpoint and 1 feedback signal are used, parameter 418 *Setpoint 1* will be added to the remote reference. The sum of the remote reference and *Setpoint 1* becomes the resulting reference, which will then be compared with the feedback signal.

1 setpoint and 2 feedbacks

Just like in the above situation, the remote reference is added to *Setpoint 1* in parameter 418. Depending on the feedback function selected in parameter 417 *Feedback function*, a calculation will be made of the feedback signal with which the sum of the references and the setpoint is to be compared. A description of the individual feedback functions is given in parameter 417 *Feedback function*.

2 Setpoints and 2 feedbacks

Used in 2-zone regulation, where the function selected in parameter 417 *Feedback function* calculates the setpoint to be added to the remote reference.

★ = factory setting. () = display text [] = value for use in communication via serial communication port

Feedback handling, cont.

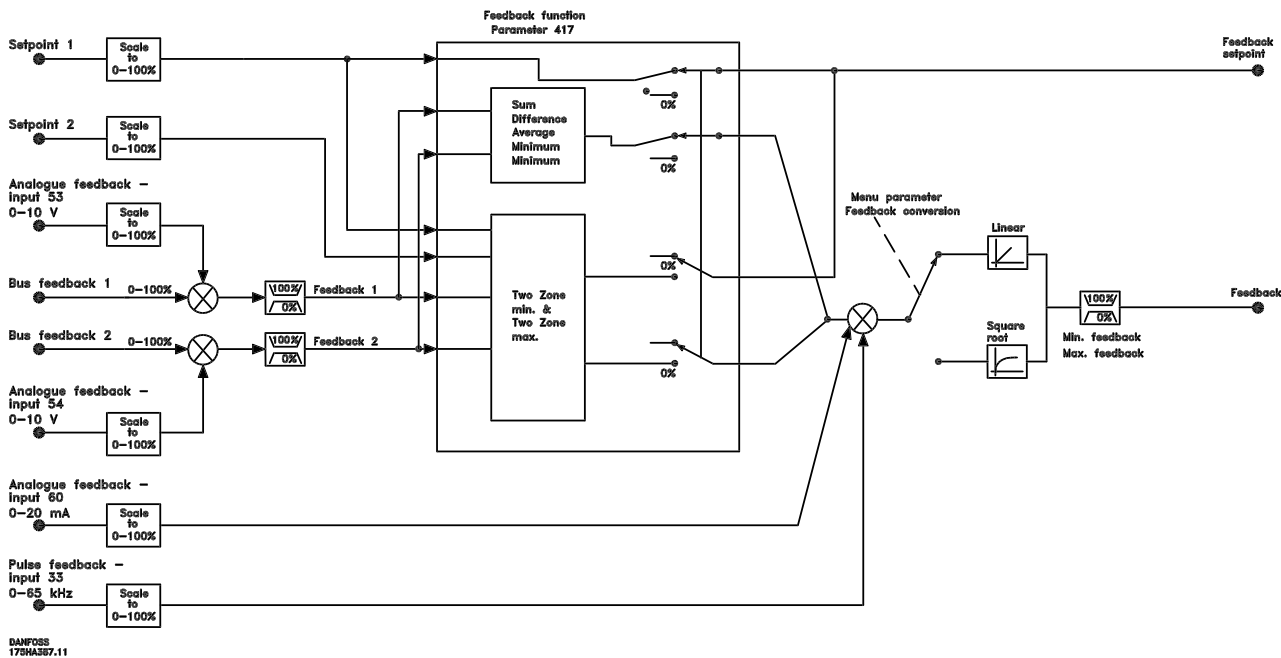

416 Feedback conversion (FFEEDBACK CONV.)

Value:

- ★ Linear (LINEAR) [0]
- Square root (SQUARE ROOT) [1]

Function:

In this parameter, a function is selected which converts a connected feedback signal from the process to a feedback value that equals the square root of the connected signal. This is used, e.g. where regulation of a flow (volume) is required on the basis of pressure as feedback signal (flow = constant x $\sqrt{\text{pressure}}$). This conversion makes it possible to set the reference in such a way that there is a linear connection between the reference and the flow required. See drawing in next column. Feedback conversion should not be used if 2-zone regulation in parameter 417 *Feedback function* has been selected.

Description:

If *Linear* [0] is selected, the feedback signal and the feedback value will be proportional. If *Square root* [1] is selected, the VLT frequency converter translates the feedback signal to a squared feedback value.

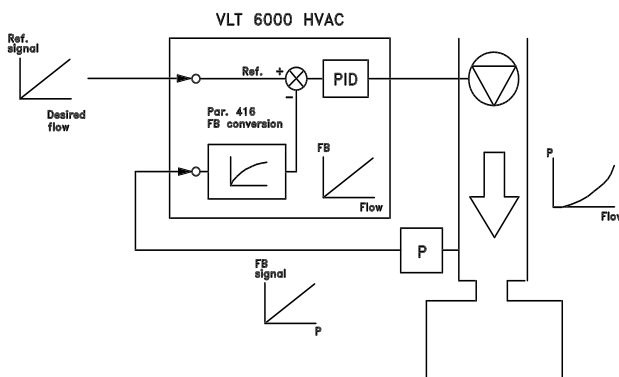

★ = factory setting. () = display text [] = value for use in communication via serial communication port

**417 Feedback function
(2 FEEDBACK, CALC.)**
Value:

Minimum (MINIMUM)	[0]
★ Maximum (MAXIMUM)	[1]
Sum (SUM)	[2]
Difference (DIFFERENCE)	[3]
Average (AVERAGE)	[4]
2-zone minimum (2 ZONE MIN)	[5]
2-zone maximum (2 ZONE MAX)	[6]

Function:

This parameter allows a choice between different calculation methods whenever two feedback signals are used.

Description of choice:

If *Minimum* [0] is selected, the VLT frequency converter will compare *feedback 1* with *feedback 2* and regulate on the basis of the lower feedback value. *Feedback 1* = Sum of parameter 535 *Bus feedback 1* and the feedback signal value of terminal 53. *Feedback 2* = Sum of parameter 536 *Bus feedback 2* and the feedback signal value of terminal 54.

If *Maximum* [1] is selected, the VLT frequency converter will compare *feedback 1* with *feedback 2* and regulate on the basis of the higher feedback value.

If *Sum* [2] is selected, the VLT frequency converter will total *feedback 1* with *feedback 2*. Please note that the remote reference will be added to *Setpoint 1*.

If *Difference* [3] is selected, the VLT frequency converter will subtract *feedback 1* from *feedback 2*.

If *Average* [4] is selected, the VLT frequency converter will calculate the average of *feedback 1* and *feedback 2*. Please note that the remote reference will be added to the *Setpoint 1*.

If *2-zone minimum* [5] is selected, the VLT frequency converter will calculate the difference between *Setpoint 1* and *feedback 1* as well as *Setpoint 2* and *feedback 2*.

After this calculation, the VLT frequency converter will use the larger difference. A positive difference, i.e. a setpoint higher than the feedback, is always larger than a negative difference.

If the difference between *Setpoint 1* and *feedback 1* is the larger of the two, parameter 418 *Setpoint 1* will be added to the remote reference.

If the difference between *Setpoint 2* and *feedback 2* is the larger of the two, the remote reference will be added to the parameter 419 *Setpoint 2*.

If *2-zone maximum* [6] is selected, the VLT frequency converter will calculate the difference between *Setpoint 1* and *feedback 1* as well as *Setpoint 2* and *feedback 2*.

After the calculation, the VLT frequency converter will use the smaller difference. A negative difference, i.e. one where the setpoint is lower than the feedback, is always smaller than a positive difference.

If the difference between *Setpoint 1* and *feedback 1* is the smaller of the two, the remote reference will be added to the parameter 418 *Setpoint 1*.

If the difference between *Setpoint 2* and *feedback 2* is the smaller of the two, the remote reference will be added to parameter 419 *Setpoint 2*.

418 Setpoint 1 (SETPOINT 1)
Value:

Ref_{MIN} - Ref_{MAX} ★ 0.000

Function:

Setpoint 1 is used in closed loop as the reference to compare the feedback values with. See description of parameter 417 *Feedback function*.

The setpoint can be offset with digital, analog or bus references, see *Reference handling*.

Used in *Closed loop* [1] parameter 100 *Configuration*.

Description of choice:

Set the required value. The process unit is selected in parameter 415 *Process units*.

★ = factory setting. () = display text [] = value for use in communication via serial communication port

419 Setpoint 2 (SETPOINT 2)
Value:
 $Ref_{MIN} - Ref_{MAX}$ ★ 0.000

Function:

Setpoint 2 is used in closed loop as the reference to compare the feedback values with. See description of parameter 417 *Feedbackfunction*.

The setpoint can be offset with digital, analog or bus signals, see reference handling.

Used in *Closed loop* [1] parameter 100 *Configuration* and only if 2-zone minimum/maximum is selected in parameter 417 *Feedbackfunction*.

Description of choice:

Set the required value. The process unit is selected in parameter 415 *Process units*.

**420 PID normal/inverse control
(PID NOR/INV. CTRL)**
Value:

★ Normal (NORMAL) [0]
Inverse (INVERSE) [1]

Function:

It is possible to choose whether the process regulator is to increase/reduce the output frequency if there is a deviation between reference/setpoint and the actual process state.

Used in *Closed loop* [1] (parameter 100).

Description of choice:

If the VLT frequency converter is to reduce the output frequency in case the feedback signal increases, select *Normal* [0].

If the VLT frequency converter is to increase the output frequency in case the feedback signal increases, select *Inverse* [1].

421 PID anti windup
(PID ANTI WINDUP)
Value:

Off (DISABLE) [0]
★ On (ENABLE) [1]

Function:

It is possible to choose whether the process regulator is to continue regulating on a deviation even if it is not possible to increase/reduce the output frequency.

Used in *Closed loop* [1] (parameter 100).

Description of choice:

The factory setting is *On* [1], which means that the integration link is adjusted to the actual output frequency if either the current limit, the voltage limit or the max./min. frequency has been reached. The process regulator will not be engaged again, until either the deviation is zero or its prefix has changed. Select *Off* [0] if the integrator is to continue integrating to the deviation even if it is not possible to remove the deviation by regulation.

NB!

If *Off* [0] is selected, it will mean that when the deviation changes its prefix, the integrator will first have to integrate down from the level obtained as a result of the former error, before any change to the output frequency occurs.

422 PID start-up frequency
(PID START VALUE)
Value:

$f_{MIN} - f_{MAX}$ (parameter 201 and 202) ★ 0 Hz

Function:

When the start signal comes, the VLT frequency converter will react in the form of *Open loop* [0] following the ramp. Only when the programmed start frequency has been obtained, will it change over to *Closed loop* [1]. In addition, it is possible to set a frequency that corresponds to the speed at which the process normally runs, which will enable the required process conditions to be reached sooner.

Used in *Closed loop* [1] (parameter 100).

Description of choice:

Set the required start frequency.



NB!

If the VLT frequency converter is running at the current limit before the desired start frequency is obtained, the process regulator will not be activated. For the regulator to be activated anyway, the start frequency must be lowered to the required output frequency. This can be done during operation.

423 PID proportional gain (PID PROP. GAIN)

Value:

0.00 - 10.00

★ 0.01

Function:

The proportional gain indicates the number of times the deviation between the reference/setpoint and the feedback signal is to be applied.

Used in *Closed loop* [1] (parameter 100).

Description of choice:

Quick regulation is obtained by a high gain, but if the gain is too high, the process may become unstable.

424 PID integration time (PID INTEGR.TIME)

Value:

0.01 - 9999.00 sec. (OFF)

★ OFF

Function:

The integrator provides a constant change of the output frequency during constant error between the reference/setpoint and the feedback signal.

The greater the error, the quicker the integrator frequency contribution will increase. The integration time is the time needed by the integrator to reach the same gain as the proportional gain for a given deviation.

Used in *Closed loop* [1] (parameter 100).

Description of choice:

Fast regulation is obtained in connection with a short integration time. However, this time may be too short, which means that the process may be destabilised as a result of overshings.

If the integral time is long, major deviations from the required set point may occur, since the process regulator will take a long time to regulate in relation to a given error.

425 PID differentiation time (PID DIFF. TIME)

Value:

0.00 (OFF) - 10.00 sec.

★ OFF

Function:

The differentiator does not react to a constant error. It only contributes when the error changes.

The quicker the error changes, the stronger the contribution from the differentiator will be. This influence is proportional to the speed by which the deviation changes.

Used in *Closed loop* [1] (parameter 100).

Description of choice:

Fast regulation can be obtained by means of a long differentiation time. However, this time may be too long, which means that the process may be destabilised as a result of overshings.

426 PID differentiator gain limit (PID DIFF. GAIN)

Value:

5.0 - 50.0

★ 5.0

Function:

It is possible to set a limit for the differentiator gain. The differentiator gain will increase if there are fast changes, which is why it can be beneficial to limit this gain, thereby obtaining a pure differentiator gain at slow changes and a constant differentiator gain where quick changes to the deviation are made. Used in *Closed loop* [1] (parameter 100).

Description of choice:

Select a limit to differentiator gain as required.

427 PID lowpass filter time

(PID FILTER TIME)

Value:

0.01 - 10.00 ★ 0.01

Function:

Oscillations on the feedback signal are dampened by the lowpass filter in order to reduce their impact on the process regulation. This can be an advantage e.g. if there is a lot of noise on the signal.

Used in *Closed loop* [1] (parameter 100).

Description of choice:

Select the desired time constant (τ). If a time constant (τ) of 0.1 s is programmed, the break frequency for the lowpass filter will be $1/0.1 = 10 \text{ RAD/sec.}$, corresponding to $(10/(2 \times \pi)) = 1.6 \text{ Hz}$.

The process regulator will thus only regulate a feedback signal that varies by a frequency lower than 1.6 Hz.

If the feedback signal varies by a higher frequency than 1.6 Hz, the Process regulator will not react.

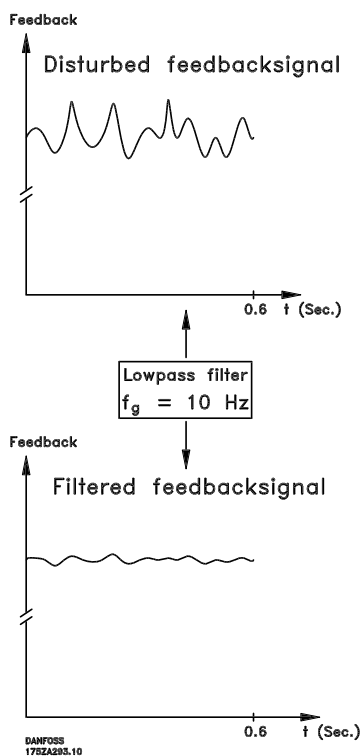

★ = factory setting. () = display text [] = value for use in communication via serial communication port

■ Serial communication for FC protocol

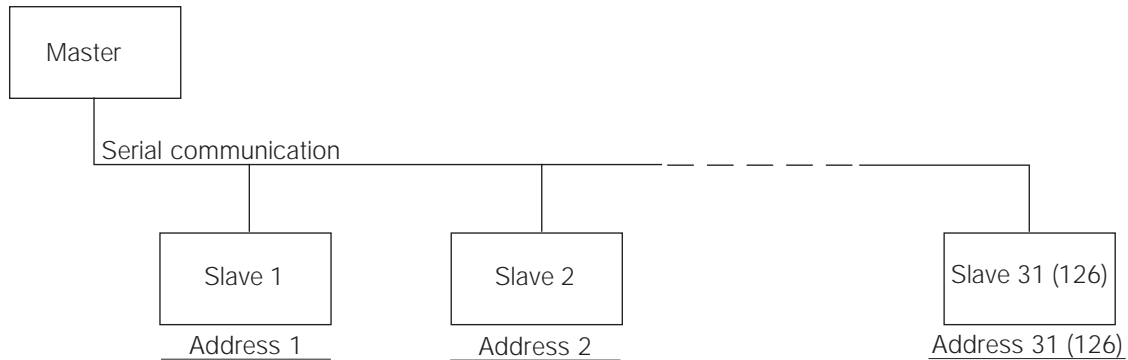

■ Protocols

As standard, all VLT 6000 HVAC units have a RS 485 port which enables a choice among three protocols. The three protocols, which can be selected in parameter 500 *Protocol*, are the following:

- Danfoss FC protokol
- Johnson Controls Metasys N2
- Landis/Staefa FLN ¹⁾

If Danfoss FC protocol is to be selected, set parameter 500 *Protocol* to *FC protocol*[0].

A description of Johnson's Control Metasys N2 and Landis/Staefa FLN is not included in this Design Guide.

For further information on Metasys N2, please order MI.60.XX.XX from your Danfoss supplier.

For further information on FLN, please order MI.60.XX.XX from your Danfoss supplier.

¹⁾ Available from approx. October 1998.

■ Telegram communication

Control and reply telegrams

The telegram communication in a master/slave system is controlled by the master. A maximum of 31 slaves (VLT 6000 HVAC) can be connected to one master, unless a repeater is used. If a repeater is used, a maximum of 126 slaves can be connected to one master.

The master continuously sends telegrams addressed to the slaves and awaits reply telegrams from these. The response time of the slaves is max. 50 ms.

Only a slave that has received a faultless telegram addressed to that slave will response by sending a reply telegram.

Broadcast

A master can send the same telegram at the same time to all slaves connected to the bus. In such *broadcast* communication, the slave does not send a reply telegram to the master, provided the telegram has been correctly received.

Broadcast communication is set up in the address format (ADR), see the next page.

Contents of a character (byte)

Each transferred character begins with a start bit. Subsequently, 8 data-bits are transferred, corresponding to one byte. Each character is secured via a parity bit set to "1" when there is even parity (i.e. an even number of binary 1's in the 8 data-bits and the parity bit combined). A character ends with a stop bit and thus consists of a total of 11 bits.

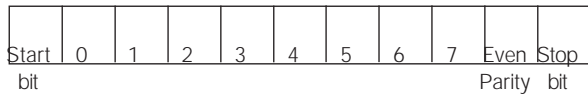

The time between individual characters in a telegram is not to exceed 2 characters and the telegram must be completed within 1.5 times the rated telegram time.

If the baudrate is 9600 kbaud and the telegram length is 16 baud, the telegram must be completed within 27.5 msec.

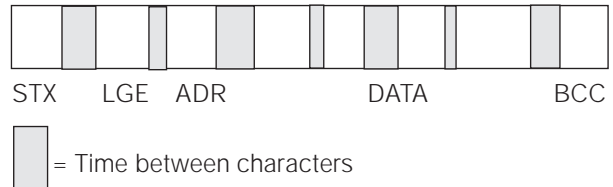

■ **Telegram build-up under FC protocol**

Each telegram begins with a start character (STX) = 02 Hex, followed by a byte that gives the telegram length (LGE) and a byte that gives the VLT address (ADR). Then follows a number of data bytes (variable, depending on telegram type). The telegram ends with a data control byte (BCC).

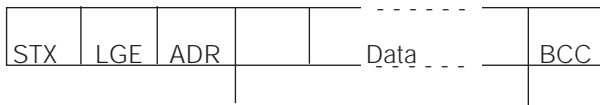

Telegram times

The speed of communication between a master and a slave depends on the baud rate. The baud rate of the VLT frequency converter must be the same as the baud rate of the master and is selected in parameter 502 *Baudrate*.

After a reply telegram from the slave, there must be a minimum pause of 2 characters (22 bits) before the master is able to send another telegram. At a baudrate of 9600 kbaud, there must be a minimum pause of 2.3 msec. After the master has completed the telegram, the response time of the slave back to the master will be max. 20 msec. and there will be a minimum pause of 2 characters.

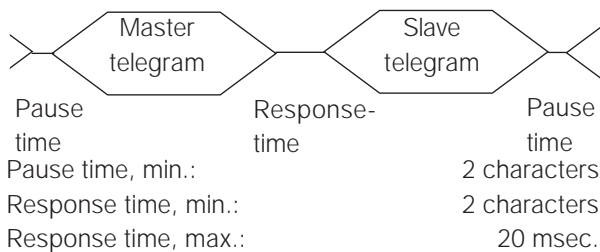

Telegram length (LGE)

The telegram length is the number of data bytes plus address byte ADR plus data control byte BCC.

Telegrams with 4 data bytes have a length of:

$$LGE = 4 + 1 + 1 = 6 \text{ bytes}$$

Telegrams with 12 data bytes have a length of:

$$LGE = 12 + 1 + 1 = 14 \text{ bytes}$$

Telegrams that contain text have a length of 10+n bytes. 10 is the fixed characters, while 'n' is variable (depending on the length of the text).

VLT frequency converter address (ADR)

Two different address formats are used, in which the address range of the VLT frequency converter is either from 1-31 or from 1-126.

1. Address format 1-31

The byte for this address range has the following profile:

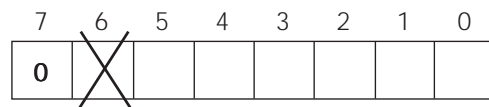

Bit 7 = 0 (address format 1-31 active)

Bit 6 is not used

Bit 5 = 1: Broadcast, address bits (0-4), not used

Bit 5 = 0: No Broadcast

Bit 0-4 = VLT frequency converter address 1-31

1. Address format 1-126

The byte for the 1-126 address range has the following profile:

7	6	5	4	3	2	1	0
1							

- Bit 7 = 1 (address format 1-126 active)
- Bit 0-6 = VLT frequency converter address 1-126
- Bit 0-6 = 0 Broadcast

The slave sends the address byte back to the master in the reply telegram in unchanged form.

Example:

A telegram is sent to VLT frequency converter address 22 using address format 1-31:

7	6	5	4	3	2	1	0
0	0	0	1	0	1	1	0

Data control byte (BCC)

The data control byte can be explained by means of an example: Before the first byte of the telegram is received, the calculated check sum (BCS) is 0.

7	6	5	4	3	2	1	0
0	0	0	0	0	0	0	0

After the first byte (02H) has been received:

$$\text{BCS} = \text{BCC EXOR "first byte"}$$

(EXOR = exclusive-or gate)

$$\text{BCS} = 00000000$$

$$\text{EXOR}$$

$$\text{"first byte"} = 00000010 (02H)$$

$$\text{BCC} = 00000010$$

Each additional, subsequent byte is gated with BCS EXOR and results in a new BCC, such as:

$$\text{BCS} = 00000010$$

$$\text{EXOR}$$

$$\text{"second byte"} = 11010110 (D6H)$$

$$\text{BCC} = 11010100$$

■ Data character (byte)

The build-up of data blocks depends on the type of telegram. There are three types of telegram and the telegram type applies to both control telegram (master→slave) and reply telegram (slave→master). The three types of telegram are the following:

1. Parameter block, used for transferring parameters between master and slave. The data block has 12 bytes (6 words) and also contains the process block.



2. Process block, built up as a data block with four bytes (2 words), covering:
 - Control word and reference value (from master to slave)
 - Status word and present output frequency (from slave to master).

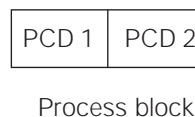

3. Text block, used for reading or writing texts via the data block.

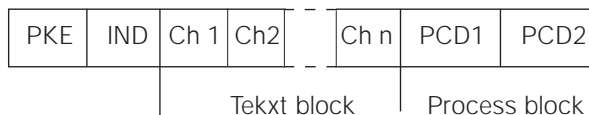

1. Parameter bytes

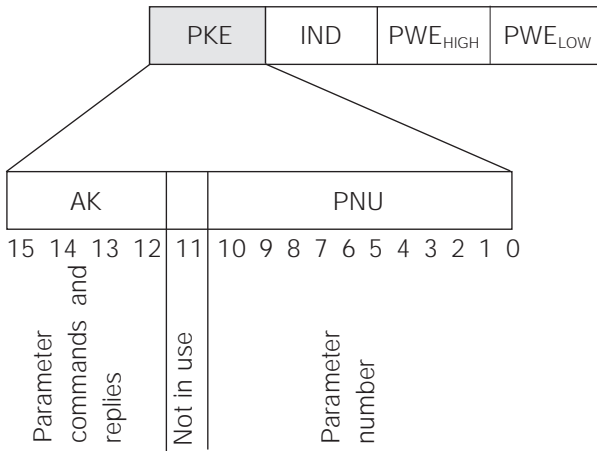

Parameter commands and replies (AK)
 Bits no. 12-15 are used for transferring parameter commands from master to slave and the slave's processed reply back to the master.

Parameter commands master→slave:

Bit no.	15	14	13	12	Parameter command
	0	0	0	0	No command
	0	0	0	1	Read parameter value
	0	0	1	0	Write parameter value in RAM (word)
	0	0	1	1	Write parameter value in RAM (double word)
	1	1	0	1	Write parameter value in RAM and EEPROM (double word)
	1	1	1	0	Write parameter value in RAM and EEPROM (word)
	1	1	1	1	Read/write text

Reply slave→master:

Bit no.	15	14	13	12	Reply
	0	0	0	0	No reply
	0	0	0	1	Parameter value transferred (word)
	0	0	1	0	Parameter value transferred (double word)
	0	1	1	1	Command cannot be executed
	1	1	1	1	Text transferred

If the command cannot be carried out, the slave will send this reply (0111) *Command cannot be executed* and give the following error message in the parameter value (PWE):

(reply 0111) Error message

0	The parameter number used does not exist
1	There is no write access to the parameter called
2	The data value exceeds the parameter limits
3	The used sub-index does not exist
4	The parameter is not of the array type
5	The data type does not match the parameter called
17	Data change in the parameter called is not possible in the present mode of the VLT frequency converter. E.g. some parameters can only be changed when the motor has stopped
130	There is no bus access to the parameter called
131	Data change is not possible because factory Setup has been selected

Parameter number PNU

Bits no. 0-10 are used for transmitting parameter numbers. The function of a given parameter can be seen from the parameter description in the *Programming* section.

Index



Index is used together with the parameter number for read/write access to parameters with an index, such as parameter 615 *Error code*.

Index has 2 bytes - a lowbyte and a highbyte. However, only the lowbyte is used. See example on the following page.

Example - Index:

The first error code (index [1]) in parameter 615 *Error code* must be read.

PKE = 1267 Hex (read parameter 615 *Error code*).

IND = 0001 Hex - Index no. 1.

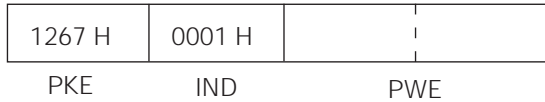

The VLT frequency converter will respond in the parameter value (PWE) block by means of an error code with a value from 1-99. See *List of warnings and alarms* to identify the error code.

Parameter value (PWE)

The parameter value block consists of 2 words (4 bytes) and its value depends on the command given (AK). If the master enquires about a parameter value, the PWE block contains no value.

If a parameter value is to be changed by the master (write), the new value is entered in the PWE block and sent to the slave.

If the slave responds to a parameter requirement (read command), the present parameter value is transferred in the PWE block and returned to the master.

If a parameter does not contain a numerical value, but several data selection options, e.g. parameter 001 *Language*, where [0] is *English* and [1] is *Danish*, the data value is selected by writing the value in the PWE block. See example on the following page.

Via the serial communication it is only possible to read parameters with data type 9 (text string). In VLT 6000 HVAC, parameters 621-631 *Nameplate data* have data type 9. For example, it is possible in parameter 621 *Unit type* to read the unit size and mains voltage range.

When a text string is transferred (read), the telegram length is variable, since the texts have different lengths. The telegram length is stated in the 2nd byte of the telegram, called LGE.

In order to read a text via the PWE block, the parameter command (AK) must be set to 'F' Hex.

The index character is used to indicate whether the command in question is a read or write command.

For a read command, the index must have the following format:

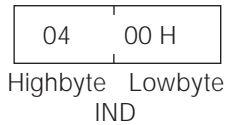

VLT 6000 HVAC has two parameters for which a text can be written: parameters 533 and 534 *Display text*, see the description of these under the parameter description. In order to write a text via the PWE block, the parameter command (AK) must be set to 'F' Hex.

For a write command, the index must have the following format:

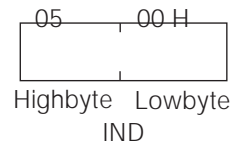
Data types supported by the VLT frequency converter

Datatype	Description
3	Integer 16
4	Integer 32
5	Unsigned 8
6	Unsigned 16
7	Unsigned 32
9	Text string

Unsigned means there is no sign included in the telegram.

Example - Write a parameter value:

Parameter 202 *Output frequency high limit, f_{MAX}* is to be changed to 100 Hz. This value must be remembered after a power failure, so it is written in EEPROM.

PKE = E0CA Hex - Write to parameter 202
Output frequency high limit, f_{MAX}
 IND = 0000 Hex
 PWE_{HIGH} = 0000 Hex
 PWE_{LOW} = 03E8 Hex - Data value 1000, corresponding to 100 Hz, see *Conversion*.

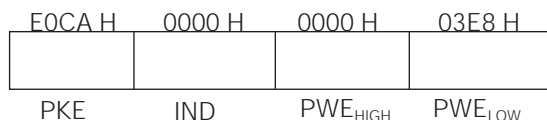

The reply from the slave to the master will be:

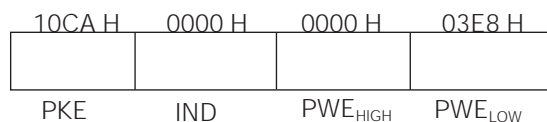

The value in parameter 206 *Ramp-up time* is required. The master sends the following enquiry:

PKE = 10CE Hex - read parameter 206
Ramp-up time
 IND = 0000 Hex
 PWE_{HIGH} = 0000 Hex
 PWE_{LOW} = 0000 Hex

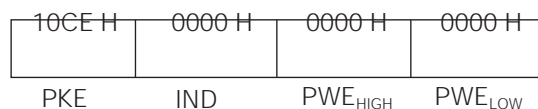

If the parameter value in parameter 206 *Ramp-up time* is 10 seconds, the reply from the slave to the master will be as follows:

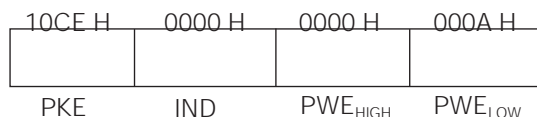

Example - Choice of a data value:

kW [20] is to be selected in parameter 415 *Process units*. This value must be remembered after a power failure, so it is written in EEPROM.

PKE = E19F Hex - Write to parameter 415
Process units
 IND = 0000 Hex
 PWE_{HIGH} = 0000 Hex
 PWE_{LOW} = 0014 Hex - Choose data choice *kW* [20]

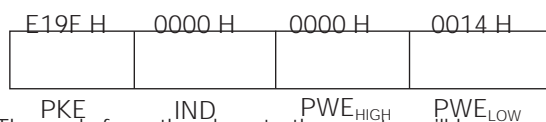

The reply from the slave to the master will be:

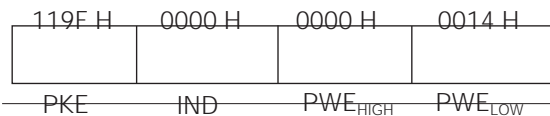

Example - Read a parameter value:

Conversion:

The different attributes for each parameter can be seen in the section on factory settings.

Since a parameter value can only be transferred as a whole number, a conversion factor must be used to transfer decimals.

Example:

Parameter 201: minimum frequency, conversion factor 0.1. If parameter 201 is to be set to 10 Hz, a value of 100 must be transferred, since a conversion factor of 0.1 means that the transferred value will be multiplied by 0.1. A value of 100 will thus be understood as 10.0.

Conversion table:

Conversion index	Conversion factor
74	3.6
2	100
1	10
0	1
-1	0.1
-2	0.01
-3	0.001
-4	0.0001

■ Process word

The process word block is divided into two blocks each of 16 bits, which always come in the sequence stated.

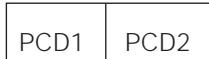

	PCD1	PCD2
Control telegram (master→slave)	Control word	Reference value
Reply telegram (slave→master)	Status word	Given output frequency

■ Control word as per FC protocol

The control word is used for transmitting commands from a master (e.g. a PC) to a slave (VLT 6000 HVAC).

Master→Slave

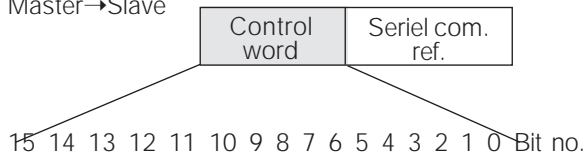

Bit	Bit = 0	Bit = 1
00		Preset ref. lsb
01		Preset ref. msb
02	DC braking	
03	Coasting stop	
04	Quick stop	
05	Freeze output frequency	
06	Ramp stop	Start
07		Reset
08		Jog
09	No function	No function
10	Data not valid	Data valid
11		Activate relay 1
12		Activate relay 2
13		Choice of setup lsb
14		Choice of setup msb
15		Reversing

Bit 00/01:

Bits 00 and 01 are used for choosing between the four pre-programmed references (parameters 211-214 *Preset reference*) in accordance with the following table:

Preset ref.	Parameter	Bit 01	Bit 00
1	211	0	0
2	212	0	1
3	213	1	0
4	214	1	1

NB!:

 Parameter 508 *Choice of preset reference* is used to choose how bits 00/01 are to be gated with the corresponding functions of the digital inputs.

Bit 02, DC BRAKE:

Bit 02 = 0 leads to DC braking and stop. Set braking current and duration in parameter 114 *DC braking current* and in parameter 115 *DC braking time*. Note: Parameter 504 *DC brake* is used for selecting how bit 02 is to be gated with the corresponding function of terminal 27.

Bit 03, Coasting stop:

Bit 03 = "0" means that the VLT frequency converter immediately "lets go" of the motor (the output transistors are "turned off"), which means that the motor runs freely until it stops.

Bit 03 = "1" means that the frequency converter is able to start the motor, provided the other conditions for starting are fulfilled. Note: In parameter 503 *Coasting stop* the choice is made of how bit 03 is to be gated with the corresponding function of terminal 27.

Bit 04, Quick stop:

Bit 04 = "0" leads to a stop in which the motor speed is ramped down to stop via parameter 207 *Ramp-down time*.

Bit 05, Freeze output frequency:

Bit 05 = "0" means that the given output frequency (in Hz) is frozen. The frozen output frequency can now only be changed via the digital inputs programmed for *Speed up* and *Speed down*.

NBI:



If *Freeze output* is active, the VLT frequency converter cannot be stopped via Bit 06 *Start* or via terminal 18. The VLT frequency converter can only be stopped in the following ways:

- Bit 03 *Coasting stop*
- Terminal 27
- Bit 02 *DC braking*
- Terminal 19 programmed for *DC braking*

Bit 06, Ramp stop/start:

Bit 04 = "0" leads to a stop in which the motor speed is ramped down to stop via parameter 207 *Ramp-down time*.

Bit 06 = "1" means that the frequency converter is able to start the motor, provided the other conditions for starting are fulfilled. Note: In parameter 505 *Start* a choice is made of the way bit 06 *Ramp stop/start* is to be gated with the corresponding function of terminal 18.

Bit 07, Reset:

Bit 07 = "0" leads to no reset.

Bit 07 = "1" means that a trip is reset.

Reset is activated on the leading edge of the signal, i.e. at the change from logic '0' to logic '1'.

Bit 08, Jog:

Bit 08 = "1" means that the output frequency is determined by parameter 209 *Jog frequency*.

Bit 09, No function:

Bit 09 has no function.

Bit 10, Data not valid/Data valid:

Used for telling the VLT 6000 HVAC whether the control is to be used or ignored. Bit 10 = "0" means that the control word is ignored. Bit 10 = "1" means that the control word is used. This function is relevant because the control word is always contained in the telegram, regardless of the type of telegram used, i.e. it is possible to disconnect the control word if it is not to be used in connection with updating or reading of parameters.

Bit 11, Relay 1:

Bit 11 = "0": Relay 1 is not activated.

Bit 11 = "1": Relay 1 is activated, provided *Control word bits 11/12* has been selected in parameter 323 *Relay outputs*.

Bit 12, Relay 2:

Bit 12 = "0": Relay 2 is not activated.

Bit 12 = "1": Relay 2 is activated, provided *Control word bits 11/12* has been selected in parameter 326 *Relay outputs*.

NBI:



If the time-out period set in parameter 556 *Bus time interval function* is exceeded, relays 1 and 2 will lose their voltage if they have been activated via serial communication.

Bits 13/14, Choice of Setup:

Bits 13 and 14 are used to choose among the four menu Setups in accordance with the following table:

Setup	Bit 14	Bit 13
1	0	0
2	0	1
3	1	0
4	1	1

This function is only possible if *Multi-setups* has been selected in parameter 004.

Note: In parameter 507 *Choice of Setup* a choice is made of the way bits 13/14 are to be gated with the corresponding function of the digital inputs.

Bit 15, No function/reversing:

Bit 15 = "0" leads to no reversing.

Bit 15 = "1" leads to reversing.

Please note that, in the factory setting, reversing has been selected as digital in parameter 506 *Reversing*, which means that bit 15 only leads to reversing, if *bus, logic or or logic and* has been selected (however, *logic and* only together with terminal 19).

■ Status word as per FC protocol

The status word is used to inform the master (e.g. a PC) of the condition of the slave (VLT 6000 HVAC).

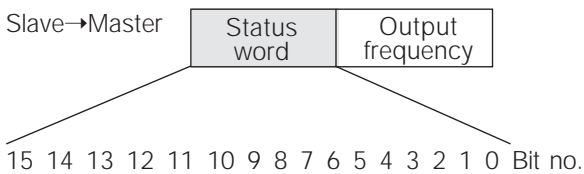

Bit	Bit = 0	Bit = 1
00	Trip	Control ready
01		Drive ready
02		Stand by
03	No trip	Trip
04	Not in use	
05	Not in use	
06	Not in use	
07	No warning	Warning
08	Speed ≠ ref.	Speed = ref.
09	Local operation	Serial com. control
10	Out of frequency range	
11		Running
12	No function	No function
13		Voltage warning high/low
14		Current limit
15		Thermal warning

Bit 00, Control ready:

Bit 00 = "1". The VLT frequency converter is ready for operation.

Bit 00 = "0". The VLT frequency converter has tripped.

Bit 01, Drive ready:

Bit 01 = "1". The VLT frequency converter is ready for operation, but terminal 27 is a logic '0' and/or a *coasting command* has been received via serial communication.

Bit 02, Stand by:

Bit 02 = "1". The VLT frequency converter is able to start the motor when a start command is given.

Bit 03, No trip/trip:

Bit 03 = "0" means that the VLT 6000 HVAC is not in an error state.

Bit 03 = "1" means that the VLT 6000 HVAC has tripped and needs a reset signal in order for operation to be resumed.

Bit 04, Not in use:

Bit 04 is not used in the status word.

Bit 05, Not in use:

Bit 05 is not used in the status word.

Bit 06, Not in use:

Bit 06 is not used in the status word.

Bit 07, No warning/warning:

Bit 07 = "0" means there is no warning.

Bit 07 = "1" means a warning has occurred.

Bit 08, Speed ≠ ref./speed = ref.:

Bit 08 = "0" means that the motor is running, but that the present speed is different from the preset speed reference. This may be the case, i.a. when the speed is ramped up/down at start/stop.

Bit 08 = "1" means that the present motor speed equals the preset speed reference.

Bit 09, Local operation/serial communication control:

Bit 09 = "0" means that OFF/STOP has been activated on the control unit, or that the VLT 6000 HVAC is in Hand mode. It is not possible to control the VLT frequency converter via serial communication.

Bit 09 = "1" means that it is possible to control the frequency converter via serial communication.

Bit 10, Out of frequency range:

Bit 10 = "0" if the output frequency has reached the value in parameter 201 *Output frequency low limit* or parameter 202 *Output frequency high limit*.

Bit 10 = "1" means that the output frequency is within the limits stated.

Bit 11, Not running/running:

Bit 11 = "0" means that the motor is not running.

Bit 11 = "1" means that the VLT 6000 HVAC has a start signal, or that the output frequency is greater than 0 Hz.

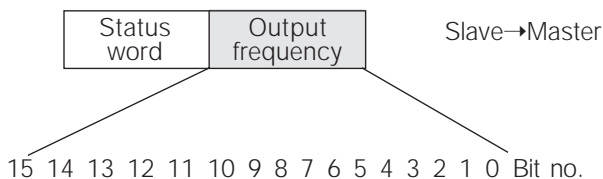
■ Present output frequency

The value of the present output frequency of the frequency converter at any given time is transmitted as a 16-bit word. The value is transmitted in the form of whole numbers 0 - ±32767 (±200 %). 16384 (4000 Hex) corresponds to 100 %.

The output frequency has the following format:

0-16384 (4000 Hex) ≅ 0-100 % (Par. 201 *Output frequency low limit* - Par. 202 *Output frequency high limit*).

Example - Status word and present output frequency:

The master receives a status message from the VLT frequency converter saying that the present output frequency is 50 % of the output frequency range.

Par. 201 *Output frequency low limit* = 0 Hz
 Par. 202 *Output frequency high limit* = 50 Hz

Status word = 0F03 Hex. Status message
 Output frequency = 2000 Hex. 50 % of the frequency range, corresponding to 25 Hz.

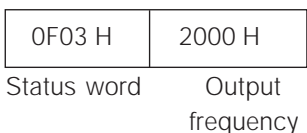

Serial communication 500 - 556

In this parameter group, the serial communication of the VLT frequency converter is set up.

There is a choice of three protocols: FC protocol, Metasys N2 and Landis/Staefa. In order to use serial communication, address and baudrate must always be set. In addition, such present operational data as reference, feedback and motor temperature can be read via serial communication.

500 Protocol (PROTOCOL)

Value:

★FC protocol (FC PROTOKOL)	[0]
Metasys N2 (METASYS N2)	[1]
Landis/Staefa FLN (LS FLN)	[2]

Function:

There is a choice of three different protocols.

Description of choice:

Select the required control word protocol.

501 Address (ADRESSE)

Value:

Parameter 500 <i>Protocol = FC protokol</i> [0]	
0 - 126	★ 1
Parameter 500 <i>Protocol = Metasys N2</i> [1]	
1 - 255	★ 1
Parameter 500 <i>Protocol = LS FLN</i> [3]	
0 - 98	★ 1

Function:

In this parameter it is possible to allocate an address in a serial communication network to each VLT frequency converter.

Description of choice:

The individual VLT frequency converter must be given a unique address.

If the number of units connected (VLT frequency converters + master) exceeds 31, an amplifier (repeater) must be used.

Parameter 501 *Address* cannot be chosen via serial communication, but must be set via the LCP control unit.

502 Baudrate (BAUDRATE)

Value:

300 Baud (300 BAUD)	[0]
600 Baud (600 BAUD)	[1]
1200 Baud (1200 BAUD)	[2]
2400 Baud (2400 BAUD)	[3]
4800 Baud (4800 BAUD)	[4]
★ 9600 Baud (9600 BAUD)	[5]

Function:

In this parameter, the speed is programmed at which data is transmitted via serial communication.

Baudrate is defined as the number of bits transmitted per second.

Description of choice:

The transmission speed of the VLT frequency converter must be set at a value that corresponds to the transmission speed of the master. Parameter 502 *Baudrate* cannot be selected via serial communication; it must be set via the LCP control unit.

The data transmission time itself, which is determined by the baudrate selected, is only part of the total communication time.

503 Coasting stop (COASTING)

Value:

Digital input (DIGITAL INPUT)	[0]
Serial communication (SERIAL PORT)	[1]
Logic and (LOGIC AND)	[2]
★ Logic or (LOGIC OR)	[3]

Function:

In parameters 503-508, a choice can be made to control the VLT frequency converter via the digital inputs and/or via serial communication.

If *Serial communication* [1] is selected, the command in question can only be activated if a command is given via serial communication.

If *Logic and* [2] is selected, the function must in addition be activated via a digital input.

Description of choice:

The table below shows when the motor is running and is coasting when *Digital input* [0], *Serial communication* [1], *Logic and* [2] or *Logic or* [3] has been selected.

NB!:

Please note that terminal 27 and bit 03 of the control word are active in the case of logic '0'.

<i>Digital input</i> [0]			<i>Serial communication</i> [1]		
Serial			Serial		
Kl. 27	com.	Function	Kl. 27	com.	Function
0	0	Coasting	0	0	Coasting
0	1	Coasting	0	1	Motor run.
1	0	Motor run.	1	0	Coasting
1	1	Motor run.	1	1	Motor run.

<i>Logic and</i> [2]			<i>Logic or</i> [3]		
Serial			Serial		
Kl. 27	com.	Function	Kl. 27	com.	Function
0	0	Coasting	0	0	Coasting
0	1	Motor run.	0	1	Coasting
1	0	Motor run.	1	0	Coasting
1	1	Motor run.	1	1	Motor run.

504 DC brake (DC BRAKE)
Value:

- Digital input (DIGITAL INPUT) [0]
- Serial communication (SERIAL PORT) [1]
- Logic and (LOGIC AND) [2]
- ★ Logic or (LOGIC OR) [3]

Function:

See functional description under parameter 503 *Coasting*.

Description of choice:

The table below shows when the motor is running and is DC-braking when *Digital input* [0], *Serial communication* [1], *Logic and* [2] or *Logic or* [3] has been selected.

NB!:

Please note that *DC braking inverse* [3] via terminal 19, terminal 27 and bit 03 of the control word is active in the case of logic '0'.

<i>Digital input</i> [0]			<i>Serial communication</i> [1]		
Serial			Serial		
Term. 19/27	com.	Function	Term. 19/27	com.	Function
0	0	DC-brake	0	0	DC-brake
0	1	DC-brake	0	1	Motor run.
1	0	Motor run.	1	0	DC-brake
1	1	Motor run.	1	1	Motor run.

<i>Logic and</i> [2]			<i>Logic or</i> [3]		
Serial			Serial		
Term. 19/27	com.	Function	Term. 19/27	com.	Function
0	0	DC-brake	0	0	DC-brake
0	1	Motor run.	0	1	DC-brake
1	0	Motor run.	1	0	DC-brake
1	1	Motor run.	1	1	Motor run.

505 Start (START)
Value:

- Digital input (DIGITAL INPUT) [0]
- Serial communication (SERIAL PORT) [1]
- Logic and (LOGIC AND) [2]
- ★ Logic or (LOGIC OR) [3]

Function:

See the functional description under parameter 503 *Coasting*.

Description of choice:

The table below shows when the motor has stopped and gives the situations in which the VLT frequency converter has a start command when *Digital input* [0], *Serial communication* [1], *Logic and* [2] or *Logic or* [3] has been selected.

<i>Digital input</i> [0]			<i>Serial communication</i> [1]		
Serial			Serial		
Kl. 18	com.	Function	Kl. 18	com.	Function
0	0	Stop	0	0	Stop
0	1	Stop	0	1	Start
1	0	Start	1	0	Stop
1	1	Start	1	1	Start

<i>Logic and</i> [2]			<i>Logic or</i> [3]		
Serial			Serial		
Kl. 18	com.	Function	Kl. 18	com.	Function
0	0	Stop	0	0	Stop
0	1	Stop	0	1	Start
1	0	Stop	1	0	Start
1	1	Start	1	1	Start

★ = factory setting. () = parameter window text. [] = value for use in communication via serial communication port

506 Reversing (REVERSING)
Value:

- ★ Digital input (DIGITAL INPUT) [0]
- Serial communication (SERIAL PORT) [1]
- Logic and (LOGIC AND) [2]
- Logic or (LOGIC OR) [3]

Function:

See the functional description under parameter 503 *Coasting*.

Description of choice:

The table below shows when the motor is running clockwise and anti-clockwise when *Digital input* [0], *Serial communication* [1], *Logic and* [2] or *Logic or* [3] has been selected.

<i>Digital input</i> [0]			<i>Serial communication</i> [1]		
Serial			Serial		
Kl. 19	com.	Function	Kl. 19	com.	Function
0	0	Clockwise	0	0	Clockwise
0	1	Clockwise	0	1	Clockwise
1	0	Anti-clock.	1	0	Clockwise
1	1	Anti-clock.	1	1	Anti-clock.

<i>Logic and</i> [2]			<i>Logic or</i> [3]		
Serial			Serial		
Kl. 19	com.	Function	Kl. 19	com.	Function
0	0	Clockwise	0	0	Clockwise
0	1	Clockwise	0	1	Anti-clock.
1	0	Clockwise	1	0	Anti-clock.
1	1	Anti-clock.	1	1	Anti-clock.

Description of choice:

The table below shows the Setup (parameter 002 *Active Setup*) that has been selected via *Digital input* [0], *Serial communication* [1], *Logic and* [2] or *Logic or* [3].

The table also shows the preset reference (parameters 211-214 *Preset reference*) that has been selected via *Digital input* [0], *Serial communication* [1], *Logic and* [2] or *Logic or* [3].

<i>Digital input</i> [0]				
Bus msb	Bus lsb	Setup/Preset msb	Setup/Preset lsb	Setup nr. Preset ref. no.
0	0	0	0	1
0	0	0	1	2
0	0	1	0	3
0	0	1	1	4
0	1	0	0	1
0	1	0	1	2
0	1	1	0	3
0	1	1	1	4
1	0	0	0	1
1	0	0	1	2
1	0	1	0	3
1	0	1	1	4
1	1	0	0	1
1	1	0	1	2
1	1	1	0	3
1	1	1	1	4

507 Selection of Setup (SELECTING OF SETUP)
508 Selection of preset reference
(SELECTING OF SPEED)
Value:

- Digital input (DIGITAL INPUT) [0]
- Serial communication (SERIAL PORT) [1]
- Logic and (LOGIC AND) [2]
- ★ Logic or (LOGIC OR) [3]

Function:

See the functional description under parameter 503 *Coasting*.

★ = factory setting. () = parameter window text. [] = value for use in communication via serial communication port

Description, cont.:

<i>Serial communication [1]</i>				
Bus msb	Bus lsb	Setup/Preset msb	Setup/Preset lsb	Setup no. Preset ref. no.
0	0	0	0	1
0	0	0	1	1
0	0	1	0	1
0	0	1	1	1
0	1	0	0	2
0	1	0	1	2
0	1	1	0	2
0	1	1	1	2
1	0	0	0	3
1	0	0	1	3
1	0	1	0	3
1	0	1	1	3
1	1	0	0	4
1	1	0	1	4
1	1	1	0	4
1	1	1	1	4

<i>Logic and [2]</i>				
Bus msb	Bus lsb	Setup/Preset msb	Setup/Preset lsb	Setup no. Preset ref. no.
0	0	0	0	1
0	0	0	1	1
0	0	1	0	1
0	0	1	1	1
0	1	0	0	1
0	1	0	1	2
0	1	1	0	1
0	1	1	1	2
1	0	0	0	1
1	0	0	1	1
1	0	1	0	3
1	0	1	1	3
1	1	0	0	1
1	1	0	1	2
1	1	1	0	3
1	1	1	1	4

<i>Logic or [3]</i>				
Bus msb	Bus lsb	Setup/Preset msb	Setup/Preset lsb	Setup no. Preset ref. no.
0	0	0	0	1
0	0	0	1	2
0	0	1	0	3
0	0	1	1	4
0	1	0	0	2
0	1	0	1	2
0	1	1	0	4
0	1	1	1	4
1	0	0	0	3
1	0	0	1	4
1	0	1	0	3
1	0	1	1	4
1	1	0	0	4
1	1	0	1	4
1	1	1	0	4
1	1	1	1	4

★ = factory setting. () = parameter window text. [] = value for use in communication via serial communication port

509 - 532 Data read-out

Value:

Parameter no.	Description	Display text	Unit	Updating interval
509	Resulting reference	(REFERENCE %)	%	80 msec.
510	Resulting reference [unit]	(REFERENCE [UNIT])	Hz, rpm	80 msec.
511	Feedback [unit]	(FEEDBACK)	Par. 415	80 msec.
512	Frequency [Hz]	(FREQUENCY)	Hz	80 msec.
513	User-defined read-out	(CUSTOM READOUT)	Hz x scaling	80 msec.
514	Motor current [A]	(CURRENT)	Amp	80 msec.
515	Power [kW]	(POWER KW)	kW	80 msec.
516	Power [HP]	(POWER HK)	HP	80 msec.
517	Motor voltage [V]	(MOTOR VOLT)	V _{AC}	80 msec.
518	DC link voltage [V]	(DC LINK VOLTAGE)	V _{DC}	80 msec.
519	Thermal load, motor [%]	(MOTOR TEMPERATURE)	%	80 msec.
520	Thermal load, VLT [%]	(VLT TEMPERATURE)	%	80 msec.
521	Digital input	(DIGITAL INPUT)	Binary	80 msec.
522	Terminal 53, analogue input [V]	(TERMINAL 53, ANALOG INPUT)	Volt	20 msec.
523	Terminal 54, analogue input [V]	(TERMINAL 54, ANALOG INPUT)	Volt	20 msec.
524	Terminal 60, analogue input [mA]	(TERMINAL 60, ANALOG INPUT)	mA	20 msec.
525	Pulse reference [Hz]	(PULSE REFERENCE)	Hz	20 msec.
526	External reference [%]	(EXTERNAL REFERENCE)	%	20 msec.
527	Status word	(STATUS WORD HEX)	Hex	20 msec.
528	Heat sink temperature [°C]	(HEAT SINK TEMP.)	°C	1.2 sec.
529	Alarm word	(ALARM WORD, HEX)	Hex	20 msec.
530	Control word	(VLT CONTROL WORD, HEX)	Hex	2 msec.
531	Warning word	(WARNING WORD)	Hex	20 msec.
532	Extended status word	(STATUS WORD)	Hex	20 msec.

Function:

These parameters can be read out via the serial communication port and via the display. See also parameters 007-010 *Display read-out*.

Description of choice:
Resulting reference, parameter 509:

gives a percentage for the resulting reference in the range from *Minimum reference, Ref_{MIN}* to *Maximum reference, Ref_{MAX}*. See also reference handling, pages 89.

Resulting reference [unit], parameter 510:

gives the resulting reference by means of the unit Hz in *Open loop* (parameter 100). In *Closed loop*, the reference unit is selected in parameter 415 *Units with closed loop*.

Feedback [unit], parameter 511:

gives the resulting feedback value by means of the unit/scaling selected in parameters 413, 414 and 415. See also feedback handling, pages 115.

Frequency [Hz], parameter 512:

gives the output frequency from the VLT frequency converter.

Description of choices under parameters 509-523,
cont.:

User-defined read-out, parameter 513:

gives a user-defined value calculated on the basis of the present output frequency and unit, as well as the scaling in selected in parameter 005 *Max. value of user-defined read-out*. The unit is selected in parameter 006 *Unit for user-defined read-out*.

Motor current [A], parameter 514:

Gives the motor phase current measured as an effective value.

Power [kW], parameter 515:

Gives the present power absorption of the motor in kW.

Power [HP], parameter 516:

Gives the present power absorption of the motor in HP.

Motor voltage, parameter 517:

Gives the voltage fed to the motor.

DC link voltage, parameter 518:

Gives the intermediate circuit voltage of the VLT frequency converter.

Thermal load, motor [%], parameter 519:

Gives the calculated/estimated thermal load on the motor. 100 % is the cut-out limit. See also parameter 117 *Motor thermal protection*.

Thermal protection, VLT [%], parameter 520:

Gives the calculated/estimated thermal load on the VLT frequency converter. 100 % is the cut-out limit.

Digital input, parameter 521:

Gives the signal status of the 8 inputs (16, 17, 18, 19, 27, 29, 32 and 33). Input 16 corresponds to the bit to the extreme left.

'0' = no signal, '1' = signal connected.

Terminal 53, analogue input [V], parameter 522:

Gives the voltage value of the signal on terminal 53.

Terminal 54, analogue input [V], parameter 523:

Gives the voltage value of the signal on terminal 54.

Terminal 60, analogue input [mA], parameter 524:

Gives the current value of the signal on terminal 60.

Pulse reference [Hz], parameter 525:

Gives a pulse frequency in Hz connected to one of the terminals 17 and 29.

External reference, parameter 526:

Gives the sum of external references as a percentage (sum of analogue/pulse/serial communication) in the range from *Minimum reference, Ref_{MIN}* to *Maximum reference, Ref_{MAX}*.

Status word, parameter 527:

Gives the present status word of the VLT frequency converter in Hex.

Heat sink temperature, parameter 528:

Gives the present heat sink temperature of the VLT frequency converter. The cut-out limit is 90 ± 5 °C, while cutting back in is effected at 60 ± 5 °C.

Alarm word, parameter 529:

Gives a Hex code for the alarm on the VLT frequency converter. See page 140 for further information.

Control word, parameter 530:

Gives the present control word of the VLT frequency converter in Hex.

Warning word, parameter 531:

Indicates in Hex whether there is a warning on the VLT frequency converter. See page 140 for further information.

Extended status word, parameter 532:

Indicates in Hex code whether there is a warning on the VLT frequency converter. See page 140 for further information.

★ = factory setting. () = parameter window text. [] = value for use in communication via serial communication port

533 Display text 1 (DISPLAY TEXT ARRAY 1)
Value:

Max. 20 characters [XXXXXXXXXX]

Function:

Here, a text of max. 20 characters can be written that will be shown in display line 1, provided *LCP display text* [27] has been selected in parameter 007 *Large display read-out*. Example of display text.

Description of choice:

 Write the required text via serial communication.

534 Display text 2 (DISPLAY TEXT ARRAY 2)
Value:

Max. 8 characters [XXXXXXXXXXXXXXXXXXXX]

Function:

Here, a text of max. 8 characters can be written that will be shown in display line 2, provided *LCP display text* [27] has been selected in parameter 007 *Large display read-out*.

Description of choice:

 Write the required text via serial communication.

535 Bus feedback 1 (BUS FEEDBACK1)
Value:

0 - 16384 decimal (0 - 4000 Hex) ★ 0

Function:

Via the serial communication port, this parameter allows writing of a bus feedback value which will then form part of the feedback handling (see page xx). Bus feedback 1 will be added to any feedback value registered on terminal 53.

Description of choice:

 Write the required bus feedback value via serial communication.

536 Bus feedback 2 (BUS FEEDBACK 2)
Value:

0 - 16384 decimal (0 - 4000 Hex) ★ 0

Function:

Via serial communication, a bus feedback value could be written in this parameter that would subsequently become part of the feedback handling system (see page xxx). Bus feedback 2 will be added to any feedback value on terminal 54.

Description of choice:

 Write the required bus feedback value via the serial communication.

Warning words 1+2 and Alarm word

Warning word, extended status word and alarm word are shown in Hex format on the display. If there is more than one warning or alarm, a sum of the total warnings or alarms will be shown.

The descriptions relating to the extended status word can be seen from page 129, and with respect to warning word, extended status word and alarm word, the descriptions can also be read out via the serial bus in parameter 531 *Warning word*, 532 *Extended status word* and 529 *Alarm word*.

Hex code	Extended status word
00000001	Overvoltage control active
00000002	Start delay
00000004	Sleep boost active
00000008	Sleep mode active
00000010	Automatic motor adaptation completed
00000020	Automatic motor adaptation running
00000040	Reversing and start
00000080	Ramp operation
00000100	Reversing
00000200	Speed = reference
00000400	Running
00000800	Local ref. = 0, Remote controlled ref. = 1
00001000	OFF mode = 1
00002000	Auto mode = 0, Hand mode = 1
00004000	Start blocked
00008000	Start blocked signal missing
00010000	Freeze output
00020000	Freeze output blocked
00040000	Jogging
00080000	Jog blocked
00100000	Stand by
00200000	Stop
00400000	DC stop
00800000	Drive ready
01000000	Relay 123 active
02000000	Drive ready
04000000	Control ready
08000000	Start prevented
10000000	Profibus OFF3 active
20000000	Profibus OFF2 active
40000000	Profibus OFF1 active
80000000	Reserved

Hex code	Warning word
00000001	Reference high
00000002	Fault in EEprom on control card
00000004	Fault in EEprom on power card
00000008	HPFB bus timeout
00000010	Serial communication timeout
00000020	Overcurrent
00000040	Current limit
00000080	Motor thermistor
00000100	Motor overtemperature
00000200	Inverter overtemperature
00000400	Undervoltage
00000800	Overvoltage
00001000	Voltage warning low
00002000	Voltage warning high
00004000	Mains phase fault
00008000	Live zero fault
00010000	Under 10 Volt (terminal 50)
00020000	Reference low
00040000	Feedback high
00080000	Feedback low
00100000	Output current high
00200000	Out of frequency range
00400000	Profibus communication fault
00800000	Output current low
01000000	Output frequency high
02000000	Output frequency low
04000000	AMA - motor too small
08000000	AMA - motor too big
10000000	AMA - check par. 102, 103, 105
20000000	AMA - check par. 102, 104, 106
40000000	Reserved
80000000	Reserved

Bit (Hex)	Alarm word
00000001	Unknown fault
00000002	Trip locked
00000004	Auto-optimisation not OK
00000008	HPFB bus timeout
00000010	Serial communication timeout
00000020	ASIC fault
00000040	HPFP bus timeout
00000080	Standard bus timeout
00000100	Short-circuiting
00000200	Switchmode fault
00000400	Earth fault
00000800	Current limit
00001000	Overcurrent
00002000	Motor thermistor
00004000	Motor overheated
00008000	Inverter overheated
00010000	Undervoltage
00020000	Overvoltage
00040000	Mains phase fault
00080000	Live zero fault
00100000	Heat sink temperature too high
00200000	Motor phase W missing
00400000	Motor phase V missing
00800000	Motor phase U missing
01000000	Profibus communication fault
02000000	Inverter fault
04000000	Output current low
08000000	Safety stop
10000000	Reserved

■ Service functions 600-631

This parameter group contains functions such as operating data, data log and fault log.

It also has information on the nameplate data of the VLT frequency converter.

These service functions are very useful in connection with operating and fault analysis in an installation.

600-605 Operating data

Value:

Parameter no.	Description Operating data:	Display text	Unit	Range
600	Operating hours	(OPERATING HOURS)	Hours	0 - 130,000.0
601	Hours run	(RUNNING HOURS)	Hours	0 - 130,000.0
602	kWh counter	(KWH COUNTER)	kWh	-
603	No. of cut-ins	(POWER UP'S)	Nos.	0 - 9999
604	No. of overtemps.	(OVER TEMP'S)	Nos.	0 - 9999
605	No. of overvoltages	(OVER VOLT'S)	Nos.	0 - 9999

- Unit-dependent

Function:

These parameters can be read out via the serial communication port, as well as via the display in the parameters.

Description of choice:
Parameter 600 Operating hours:

Gives the number of hours in which the VLT frequency converter has been in operation. The value is saved every hour and when the power supply to the unit is cut off. This value cannot be reset.

Parameter 601 Hours run:

Gives the number of hours in which the motor has been in operation since being reset in parameter 619 *Reset of hours-run counter*. The value is saved every hour and when the power supply to the unit is cut off.

Parameter 602 kWh counter:

Gives the output power of the VLT frequency converter. The calculation is based on the mean value in kWh over one hour. This value can be reset using parameter 618 *Reset of kWh counter*. Range: 0 - depends on unit.

Parameter 603 No. of cut-ins:

Gives the number of cut-ins of supply voltage to the VLT frequency converter.

Parameter 604 No. of overtemps:

Gives the number of overtemperature errors on the heat-sink of the VLT frequency converter.

Parameter 605 No. of overvoltages:

Gives the number of overvoltages on the intermediate circuit voltage of the VLT frequency converter. The count is only taken when Alarm 7 *Overvoltage* is active.

606 - 614 Data log

Value:

Parameter no.	Description Data log:	Display text	Unit	Range
606	Digital input	(LOG: DIGITAL INP)	Decimal	0 - 255
607	Control word	(LOG: BUS COMMAND)	Decimal	0 - 65535
608	Status word	(LOG: BUS STAT WD)	Decimal	0 - 65535
609	Reference	(LOG: REFERENCE)	%	0 - 100
610	Feedback	(LOG: FEEDBACK)	Par. 414	-999,999.999 - 999,999.999
611	Output frequency	(LOG: MOTOR FREQ.)	Hz	0.0 - 999.9
612	Output voltage	(LOG: MOTOR VOLT)	Volt	50 - 1000
613	Output current	(LOG: MOTOR CURR.)	Amp	0.0 - 999.9
614	DC link voltage	(LOG: DC LINK VOLT)	Volt	0.0 - 999.9

Function:

With these parameters, it is possible to see up to 20 saved values (data logs) - [1] being the most recent and [20] the oldest log. When a start command has been given, a new entry to the data log is made every 160 ms. If there is a trip or if the motor has stopped, the 20 latest data log entries will be saved and the values will be visible in the display. This is useful, e.g. in the case of service after a trip.

The data log number is given in square brackets; [1]

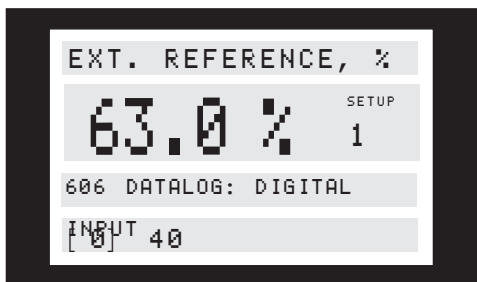

Data logs [1]-[20] can be read by first pressing [CHANGE DATA], followed by the [+/-] keys to change data log numbers.

Parameters 606-614 *Data log* can also be read out via the serial communication port.

Description of choice:

Parameter 606 *Data log: Digital input:*

This is where the latest log data are shown in decimal code, representing the status of the digital inputs. Translated into binary code, terminal 16 corresponds to the bit to the extreme left and to decimal code 128. Terminal 33 corresponds to the bit to the extreme right and to decimal code 1.

The table can be used, e.g., for converting a decimal number into a binary code. For example, digital 40 corresponds to binary 00101000. The nearest smaller decimal number is 32, corresponding to a signal on terminal 18. 40-32 = 8, corresponds to the signal on terminal 27.

Terminal	16	17	18	19	27	29	32	33
Decimal number	128	64	32	16	8	4	2	1

Parameter 607 *Data log: Control word:*

This is where the latest log data are given in decimal code for the control word of the VLT frequency converter.

The control word read can only be changed via serial communication.

The control work is read as a decimal number which is to be converted into hex.

See the control word profile under the section *Serial communication* in the Design Guide.

Parameter 608 *Data log: Status word:*

This gives the latest log data in decimal code for the status word.

The status word is read as a decimal number which is to be converted into hex.

See the status word profile under the section *Serial communication* in the Design Guide.

Parameter 609 *Data log: Reference:*

This gives the latest log data for the resulting reference.

Parameter 610 *Data log: Feedback:*

This gives the latest log data for the feedback signal.

Parameter 611 *Data log: Output frequency:*

This gives the latest log data for the output frequency.

Parameter 612 *Data log: Output voltage:*

This gives the latest log data for the output voltage.

Parameter 613 *Data log: Output current:*

This gives the latest log data for the output current.

Parameter 614 *Data log: DC-link voltage:*

This gives the latest log data for the intermediate circuit voltage.

★ = factory setting. () = display text [] = value for use in communication via serial communication port

615 Fault log: Error code
(F. LOG: ERROR CODE)
Value:

[Index 1-10] Error Code: 0 - 99

Function:

This parameter makes it possible to see the reason why a trip (cut-out of the VLT frequency converter) occurs.
 10 [1-10] log values are stored.
 The lowest log number [1] contains the latest/most recently saved data value; the highest log number [10] contains the oldest data value.
 If there is a trip on the VLT 6000 HVAC, it is possible to see its cause, the time and possibly the values for output current or output voltage.

Description of choice:

Stated as an error code in which the number refers to a table on page 100.
 The fault log is only reset after manual initialisation, see page 73.

616 Fault log: Time
(F. LOG: TIME)
Value:

[Index 1-10] Hours: 0 - 130,000.0

Function:

This parameter makes it possible to see the total number of hours run in connection with the 10 latest trips.
 10 [1-10] log values are stored.
 The lowest log number [1] contains the latest/most recently saved data value, while the highest log number [10] contains the oldest data value.

Description of choice:

The fault log is only reset after manual initialisation, see page 73.

617 Fault log: Value
(F. LOG: VALUE)
Value:

[Index 1 - 10] Value: 0 - 9999

Function:

This parameter makes it possible to see the value at which a trip occurred. The unit of the value depends on the alarm active in parameter 615 *Fault log: Error code*.

Description of choice:

The fault log is only reset after manual initialisation, see page 73.

618 Reset of kWh counter
(RESET KWH COUNT)
Value:

- ★ No reset (DO NOT RESET) [0]
- Reset (RESET COUNTER) [1]

Function:

Reset to zero of parameter 602 *kWh counter*.

Description of choice:

If *Reset* [1] has been selected and when the [OK] key is pressed, the kWh counter of the VLT frequency converter is reset. This parameter cannot be selected via the serial port, RS 485.



NB!
 When the [OK] key has been activated, the reset has been carried out.

619 Reset of hours-run counter
(RESET RUN. HOUR)
Value:

- ★ No reset (DO NOT RESET) [0]
- Reset (RESET COUNTER) [1]

Function:

Reset to zero of parameter 601 *Hours-run*.

Description of choice:

If *Reset* [1] has been selected and when the [OK] key is pressed, parameter 601 *Hours-run* is reset. This parameter cannot be selected via the serial port, RS 485.



NB!
 When the [OK] key has been activated, the reset has been carried out.

★ = factory setting. () = display text [] = value for use in communication via serial communication port

620 Operating mode (OPERATION MODE)

Value:

★ Normal function (NORMAL OPERATION)	[0]
Function with de-activated inverter (OPER. W/INVERT.DISAB)	[1]
Control card test (CONTROL CARD TEST)	[2]
Initialisation (INITIALIZE)	[3]

Function:

In addition to its normal function, this parameter can be used for two different tests.
Furthermore, it is possible to reset to the default factory settings for all Setups, except parameters 500 *Address*, 501 *Baud rate*, 600-605 *Operating data* and 615-617 *Fault log*.

Description of choice:

Normal function [0] is used for normal operation of the motor.
Function with de-activated inverter [1] is selected if control is desired over the influence of the control signal on the control card and its functions - without the motor shaft running.
Control card [2] is selected if control of the analogue and digital inputs, analogue and digital outputs, relay outputs and the control voltage of +10 V is desired. A test connector with internal connections is required for this test.

The test connector for the *Control card* [2] is set up as follows:

- connect 4-16-17-18-19-27-29-32-33;
- connect 5-12;
- connect 39-20-55;
- connect 42 - 60;
- connect 45-53-54.

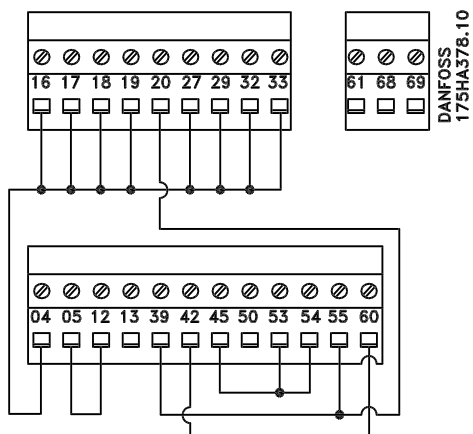

Use the following procedure for the control card test:

- 1) Select *Control card test*.
- 2) Cut off the mains supply and wait for the light in the display to go out.
- 3) Insert the test plug (see preceding column).
- 4) Connect to mains.
- 5) The VLT frequency converter expects the [OK] key to be pressed (the test cannot be run without LCP).
- 6) The VLT frequency converter automatically tests the control card.
- 7) Remove the test connector and press the [OK] key when the VLT frequency converter displays "TEST COMPLETED".
- 8) Parameter 620 *Operating mode* is automatically set to *Normal function*.

If the control card test fails, the VLT frequency converter will display "TEST FAILED". Replace the control card.

Initialisation [3] is selected if the factory setting of the unit is to be generated without resetting parameters 500 *Address*, 501 *Baud rate*, 600-605 *Operating data* and 615-617 *Fault log*.

Procedure for initialisation:

- 1) Select *Initialisation*.
- 2) Press the [OK] key.
- 3) Cut off the mains supply and wait for the light in the display to go out.
- 4) Connect to mains.
- 5) Initialisation of all parameters will be carried out in all Setups with the exception of parameters 500 *Address*, 501 *Baud rate*, 600-605 *Operating data* and 615-617 *Fault log*.

Manual initialisation is another option. See procedure on page 73.

★ = factory setting. () = display text [] = value for use in communication via serial communication port

621 - 631 Nameplate

Value:

Parameter nr.	Description Nameplate:	Display text
621	Unit type	(DRIVE TYPE)
622	Power component	(POWER SECTION)
623	VLT ordering no.	(ORDERING NO)
624	Software version no.	(SOFTWARE VERSION)
625	LCP identification no.	(LCP ID NO.)
626	Database identification no.	(PARAM DB ID)
627	Power component identification no.	(POWER UNIT DB ID)
628	Application option type	(APPLIC. OPTION)
629	Application option ordering no.	(APPLIC. ORDER NO)
630	Communication option type	(COM. OPTION)
631	Communication option ordering no.	(COM. ORDER NO)

Function:

The main data for the unit can be read from parameters 621 to 631 *Nameplate* via the display or the serial communication port.

Description of choice:
Parameter 621 Nameplate: Unit type:

VLT type gives the unit size and mains voltage.
Example: VLT 6008 380-460 V.

Parameter 622 Nameplate: Power component:

This gives the type of power card fitted to the VLT frequency converter. Example: STANDARD.

Parameter 623 Nameplate: VLT ordering no.:

This gives the ordering number for the VLT type in question. Example: 1757805.

Parameter 624 Nameplate: Software version no.:

This gives the present software version number of the unit. Example: V 1.00.

Parameter 625 Nameplate: LCP identification no.:

This gives the identification number of the LCP of the unit. Example: ID 1.42 2 kB.

Parameter 626 Nameplate: Database identification no.:

This gives the identification number of the software's database. Example: ID 1.14.

Parameter 627 Nameplate: Power component identification no.:

This gives the identification number of the database of the unit. Example: ID 1.15.

Parameter 628 Nameplate: Application option type:

This gives the type of application options fitted with the VLT frequency converter.

Parameter 629 Nameplate: Application option ordering no.:

This gives the ordering number for the application option.

Parameter 630 Nameplate: Communication option type:

This gives the type of communication options fitted with the VLT frequency converter.

Parameter 631 Nameplate: Communication option ordering no.:

This gives the ordering number for the communication option.



NB!

Parameters 700-711 for relay cards are only activated if a relay option card is fitted to the VLT 6000 HVAC.

Ordering numbers can be seen from the Design Guide.

700 Relay 3, function (RELAY3 FUNCTION)

703 Relay 4, function (RELAY4 FUNCTION)

706 Relay 5, function (RELAY5 FUNCTION)

709 Relay 6, function (RELAY6 FUNCTION)

Function:

This output activates a relay switch.

Relay outputs 3/4/5/6 can be used for showing status and warnings. The relay is activated when the conditions for the relevant data values have been fulfilled.

Activation/deactivation can be programmed in parameters 701/704/707/710 *Relay 3/4/5/6, ON delay* and parameters 702/705/708/711 *Relay 3/4/5/6, OFF delay*.

See technical data on page 73.

Description of choice:

See data choice and connections on page 106.

701 Relay 3, ON delay (RELAY3 ON DELAY)

704 Relay 4, ON delay (RELAY4 ON DELAY)

707 Relay 5, ON delay (RELAY5 ON DELAY)

710 Relay 6, ON delay (RELAY6 ON DELAY)

Value:

0 - 600 sec.

★ 0 sec.

Function:

This parameter allows a delay of the cut-in time of relays 3/4/5/6 (terminals 1-2).

Description of choice:

Enter the required value.

702 Relay 3, OFF delay (RELAY3 OFF DELAY)

705 Relay 4, OFF delay (RELAY4 OFF DELAY)

708 Relay 5, OFF delay (RELAY5 OFF DELAY)

711 Relay 6, OFF delay (RELAY6 OFF DELAY)

Value:

0 - 600 sec.

★ 0 sec.

Function:

This parameter is used to delay the cut-out time of relays 3/4/5/6 (terminals 1-2).

Description of choice:

Enter the required value.

Relay 6-9:

A-B break, A-C make

Max. 240 V AC, 2 Amp.

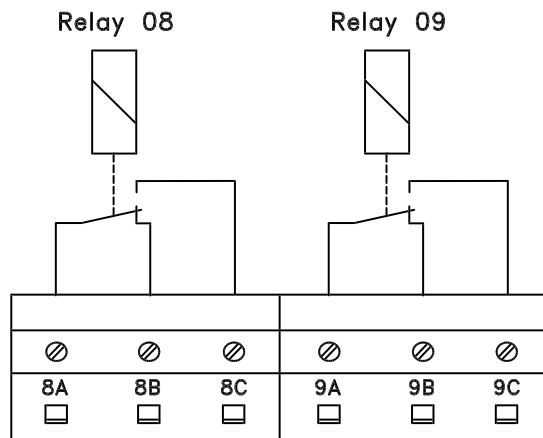
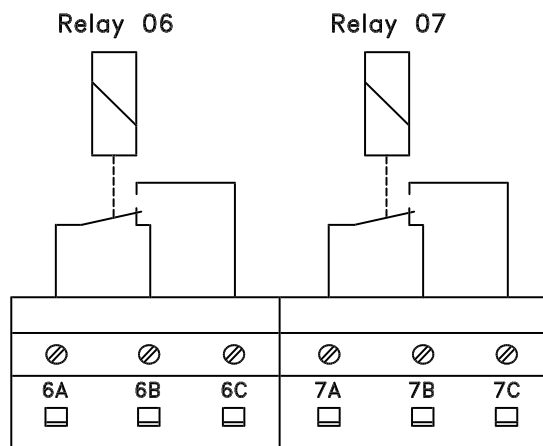

DANFOSS
175HA442.10

■ Status messages

Status messages appear in the 4th line of the display - see example below.

The left part of the status line indicates the active type of control of the VLT frequency converter.

The centre part of the status line indicates the active reference.

The last part of the status line gives the present status, e.g. "Running", "Stop" or "Stand by".

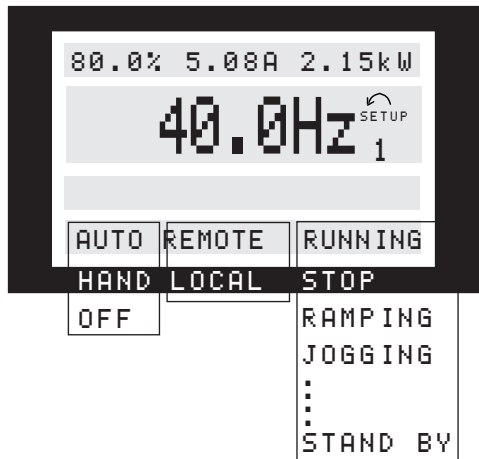
Auto mode (AUTO)

The VLT frequency converter is in Auto mode, i.e. control is carried out via the control terminals and/or serial communication. See also *Auto start* on page 70.

Hand mode (HAND)

The VLT frequency converter is in Hand mode, i.e. control is carried out via the control keys. See also *Hand start* on page 70.

OFF (OFF)

OFF/STOP is activated either by means of the control key, or by the digital inputs *Hand start* and *Auto start* both being a logic '0'. See also *OFF/STOP* on page 70.

Local reference (LOCAL)

If LOCAL has been selected, the reference is set via the [+/-] keys on the control panel. See also *Display modes* on page 71.

Remote reference (REM.)

If REMOTE has been selected, the reference is set via the control terminals or via serial communication. See also *Display modes* on page 71.

Running (RUNNING)

The motor speed now corresponds to the resulting reference.

Ramp operation (RAMPING)

The output frequency is now changed in accordance with the preset ramps.

Auto-ramp (AUTO RAMP)

Parameter 208 *Automatic ramp-up/down* is enabled, i.e. the VLT frequency converter is trying to avoid a trip from overvoltage by increasing its output frequency.

Sleep Boost (SLEEP .BST)

The boost function in parameter 406 *Boost setpoint* is enabled. This function is only possible in *Closed loop* operation.

Sleep mode (SLEEP)

The energy saving function in parameter 403 *Sleep mode timer* is enabled. This means that at present the motor has stopped, but that it will restart automatically when required.

Start delay (START DEL)

A start delay time has been programmed in parameter 111 *Start delay*. When the delay has passed, the output frequency will start by ramping up to the reference.

Run request (RUN REQ.)

A start command has been given, but the motor will be stopped until a *Run permissive* signal is received via a digital input.

Jogging (JOG)

Jog has been enabled via a digital input or via serial communication.

Jog request (JOG REQ.)

A start command has been given, but the motor will remain stopped until a *Run permissive* signal is received via a digital input.

Freeze output (FRZ.OUT)

Freeze output has been enabled via a digital input.

Status messages, cont.
Freeze output request (FRZ.REQ.)

A start command has been given, but the motor will remain stopped until a *Run permissive* signal is received via a digital input.

Reversing and start (START F/R)

Reversing and start [2] on terminal 19 (parameter 303 *Digital inputs*) and *Start* [1] on terminal 18 (parameter 302 *Digital inputs*) are enabled at the same time. The motor will remain stopped until one of the signals becomes a logic '0'.

Automatic Motor Adaptation running (AMA RUN)

Automatic motor adaptation has been enabled in parameter 107 *Automatic Motor Adaptation, AMA*.

Automatic Motor Adaptation completed (AMA STOP)

Automatic motor adaptation has been completed. The VLT frequency converter is now ready for operation after the *Reset* signal has been enabled. Please note that the motor will start after the VLT frequency converter has received the *Reset* signal.

Stand by (STANDBY)

The VLT frequency converter is able to start the motor when a start command is received.

Stop (STOP)

The motor has been stopped via a stop signal from a digital input, [OFF/STOP]-button or serial communication.

DC stop (DC STOP)

The DC brake in parameter 114-116 has been enabled.

DRIVE ready (UN. READY)

The VLT frequency converter is ready for operation, but terminal 27 is a logic '0' and/or a *Coasting command* has been received via the serial communication.

Control ready (CTR.READY)

This status is only active when a profibus option card is installed.

Not ready (NOT READY)

The VLT frequency converter is not ready for operation, because of a trip or because OFF1, OFF2 or OFF3 is a logic '0'.

Start disabled (START IN.)

This status will only be displayed if, in parameter 599 *Statemachine, Profidrive* [1] has been selected and OFF2 or OFF3 is a logic '0'.

Exceptions XXXX (EXCEPTIONS XXXX)

The microprocessor of the control card has stopped and the VLT frequency converter is out of operation. The cause may be noise on the mains, motor or control cables, leading to a stop of the control card microprocessor.
Check for EMC-correct connection of these cables.

■ List of warnings and alarms

The table gives the different warnings and alarms and indicates whether the fault locks the VLT frequency converter. After Trip locked, the mains supply must be cut and the fault must be corrected. Reconnect the mains supply and reset the VLT frequency converter before being ready. A Trip can be reset manually in three ways

- 1) Via the control key [RESET]
- 2) Via a digital input
- 3) Via serial communication

In addition, an automatic reset may be selected in parameter 400 *Reset function*.

Wherever a cross is placed under both Warning and Alarm, this can mean that a warning precedes the alarm. It can also mean that it is possible to program whether a given fault is to result in a warning or an alarm. This is possible, e.g. in parameter 117 *Motor thermal protection*. After a trip, the motor will be coasting and on the VLT frequency converter alarm and warning will flash. If the fault is removed, only the alarm will flash. After a reset, the VLT frequency converter will be ready to start operation again.

No.	Description	Warning	Alarm	Trip locked	Help
1	10 Volts low (10 VOLT LOW)	X			Page 151
2	Live zero fault (LIVE ZERO ERROR)	X	X		Page 151
4	Mains phase fault (MAINS PHASE LOSS)	X	X	X	Page 151
5	Voltage warning high (DC LINK VOLTAGE HIGH)	X			Page 151
6	Voltage warning low (DC LINK VOLTAGE LOW)	X			Page 151
7	Overvoltage (DC LINK OVERVOLT)	X	X		Page 151
8	Undervoltage (DC LINK UNDERVOLT)	X	X		Page 152
9	Inverter overloaded (INVERTER TIME)	X	X		Page 152
10	Motor overloaded (MOTOR TIME)	X	X		Page 152
11	Motor thermistor (MOTOR THERMISTOR)	X	X		Page 152
12	Current limit (CURRENT LIMIT)	X	X		Page 152
13	Overcurrent (OVERCURRENT)	X	X		Page 152
14	Earth fault (EARTH FAULT)		X	X	Page 152
15	Switch mode fault (SWITCH MODE FAULT)		X	X	Page 152
16	Short-circuit (CURR.SHORT CIRCUIT)		X	X	Page 152
17	Serial communication timeout (STD BUSTIMEOUT)	X	X		Page 152
18	HPFB bus timeout (HPFB TIMEOUT)	X	X		Page 152
19	Fault in EEprom on power card (EE ERROR POWER)	X			Page 153
20	Fault in EEprom on control card (EE ERROR CONTROL)	X			Page 153
22	Auto-optimisation not OK (AMA FAULT)		X		Page 153
29	Heat-sink temperature too high (HEAT SINK OVERTEMP.)		X	X	Page 154
30	Motor phase U missing (MISSING MOT.PHASE U)		X		Page 154
31	Motor phase V missing (MISSING MOT.PHASE V)		X		Page 154
32	Motor phase W missing (MISSING MOT.PHASE W)		X		Page 154
34	HBFB communication fault (HBFB COMM. FAULT)	X	X		Page 154
35	Out of frequency range (OUT FREQ RNG/ROT LIM)	X			Page 154
37	Inverter fault (GATE DRIVE FAULT)		X	X	Page 154
39	Check parameters 104 and 106 (CHECK P.104 & P.106)	X			Page 154
40	Check parameters 103 and 105 (CHECK P.103 & P.105)	X			Page 154
41	Motor too big (MOTOR TOO BIG)	X			Page 155
42	Motor too small (MOTOR TOO SMALL)	X			Page 155
60	Safety stop (EXTERNAL FAULT)		X		Page 155
61	Output frequency low (FOUT < FLOW)	X			Page 155
62	Output frequency high (FOUT > FHIGH)	X			Page 155
63	Output current low (I MOTOR < I LOW)	X	X		Page 155
64	Output current high (I MOTOR > I HIGH)	X			Page 155
65	Feedback low (FEEDBACK < FDB LOW)	X			Page 155
66	Feedback high (FEEDBACK > FDB HIGH)	X			Page 155
67	Reference low (REF. < REF. LOW)	X			Page 155
68	Reference high (REF. > REF. HIGH)	X			Page 155
99	Unknown fault (UNKNOWN ALARM)		X	X	Page 155

■ Warnings

A warning will flash in line 2, while an explanation is given in line 1.

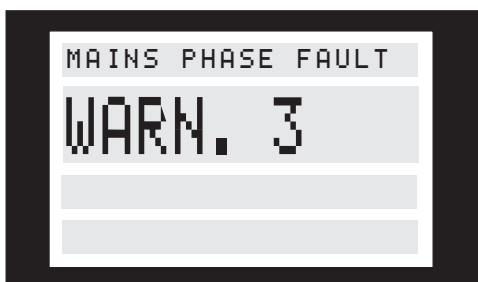

■ Alarms

If an alarm is given, the present alarm number will be shown in line 2. Lines 3 and 4 of the display will offer an explanation.

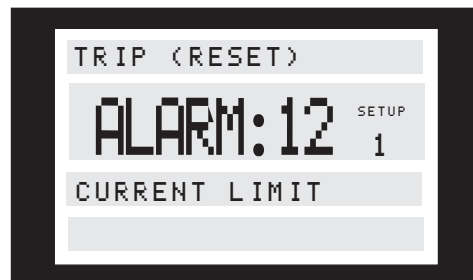

WARNING 1

Under 10 V (10 VOLT LOW)

The 10 V voltage from terminal 50 on the control card is below 10 V.

Remove some of the load from terminal 50, as the 10 Volts supply is overloaded. Max. 17 mA/min. 590 Ω.

WARNING/ALARM 2

Live zero fault (LIVE ZERO ERROR)

The current or voltage signal on terminal 53, 54 or 60 is below 50% of the value preset in parameter 309, 312 and 315 *Terminal, min. scaling*.

WARNING/ALARM 4

Phase fault (MAINS PHASE LOSS)

Phase missing on the supply side.

Check the supply voltage to the VLT frequency converter.

WARNING 5

Voltage warning high (DC LINK VOLTAGE HIGH)

The intermediate circuit voltage (DC) is higher than *Voltage warning high*, see table below. The controls of the VLT frequency converter are still enabled.

WARNING 6

Voltage warning low (DC LINK VOLTAGE LOW)

The intermediate circuit voltage (DC) is lower than *Voltage warning low*, see table below. The controls of the VLT frequency converter are still enabled.

WARNING/ALARM 7

Overvoltage (DC LINK OVERVOLT)

If the intermediate circuit voltage (DC) is higher than the *Overvoltage limit* of the inverter (see table below), the VLT frequency converter will trip after a fixed period. The length of this period depends on the unit.

Alarm/warning limits:

VLT 6000 HVAC	3 x 200 - 240 V [VDC]	3 x 380 - 460 V [VDC]
Undervoltage	211	402
Voltage warning low	222	423
Voltage warning high	384	737
Overvoltage	425	765

The voltages stated are the intermediate circuit voltage of the VLT frequency converter with a tolerance of ± 5 %. The corresponding mains voltage is the intermediate circuit voltage divided by 1,35.

Warnings and alarms, cont.**WARNING/ALARM 8****Undervoltage (DC LINK UNDERVOLT)**

If the intermediate circuit voltage (DC) drops below the *undervoltage limit* of the inverter, the VLT frequency converter will trip after a fixed period, the length of the period depending on the unit.

Furthermore, the voltage will be stated in the display. Check whether the supply voltage matches the VLT frequency converter, see *Technical data*.

WARNING/ALARM 9**Inverter overload (INVERTER TIME)**

The electronic, thermal inverter protection reports that the frequency converter is about to cut out because of an overload (too high current for too long). The counter for electronic, thermal inverter protection gives a warning at 98% and trips at 100%, while giving an alarm. The VLT frequency converter cannot be reset until the counter is below 90%.

The fault is that the VLT frequency converter is overloaded by more than 100% for too long.

WARNING/ALARM 10**Motor overtemperature (MOTOR TIME)**

According to the electronic thermal protection (ETR), the motor is too hot. Parameter 117 *Motor thermal protection* allows a choice of whether the VLT frequency converter is to give a warning or an alarm when the *Motor thermal projection* reaches 100%. The fault is that the motor is overloaded by more than 100% of the preset, rated motor current for too long. Check that the motor parameters 102-106 have been set correctly.

WARNING/ALARM 11**Motor thermistor (MOTOR THERMISTOR)**

The thermistor or the thermistor connection has been disconnected. Parameter 117 *Motor thermal protection* allows a choice of whether the VLT frequency converter is to give a warning or an alarm. Check that the thermistor has been correctly connected between terminal 53 or 54 (analogue voltage input) and terminal 50 (+ 10 V supply).

WARNING/ALARM 12**Current limit (CURRENT LIMIT)**

The current is higher than the value in parameter 215 *Current limit* I_{LIM} and the VLT frequency converter trips after the time set in parameter 412 *Trip delay overcurrent*, I_{LIM} has passed.

WARNING/ALARM 13**Overcurrent (OVER CURRENT)**

The inverter peak current limit (approx. 200% of the rated current) has been exceeded. The warning will last approx. 1-2 seconds, following which the VLT frequency converter will trip and give off an alarm. Turn off the VLT frequency converter and check whether the motor shaft can be turned and whether the motor size matches the VLT frequency converter.

ALARM: 14**Earth fault (EARTH FAULT)**

There is a discharge from the output phases to earth, either in the cable between the frequency converter and the motor or in the motor itself.

Turn off the VLT frequency converter and remove the earth fault.

ALARM: 15**Switch mode fault (SWITCH MODE FAULT)**

Fault in the switch mode power supply (internal ± 15 V supply).

Contact your Danfoss supplier.

ALARM: 16**Short-circuiting (CURR. SHORT CIRCUIT)**

There is short-circuiting on the motor terminals or in the motor itself.

Cut off the mains supply to the VLT frequency converter and remove the short-circuit.

WARNING/ALARM 17**Serial communication timeout (STD BUSTIMEOUT)**

There is no serial communication with the VLT frequency converter.

This warning will only be enabled if parameter 556 *Bus time interval function* has been set to a value different from OFF.

If parameter 556 *Bus time interval function* has been set to *Stop and trip* [5], the VLT frequency converter will first give off an alarm, then ramp down and finally trip while giving off an alarm. It is possible to increase parameter 555 *Bus time interval*.

Warnings and alarms, cont.
WARNING/ALARM 18
HPFB bus timeout (HPFB TIMEOUT)

There is no serial communication with the communication option card of the VLT frequency converter. The warning will only be enabled if parameter 804 *Bus time interval function* has been set to anything but OFF. If parameter 804 *Bus time interval function* has been set to *Stop and trip*, the VLT frequency converter will first give off an alarm, then ramp down and finally trip while giving off an alarm. Parameter 803 *Bus time interval* could possibly be increased.

WARNING 19
Fault in the EEPROM on the power card (EE ERROR POWER)

There is a fault on the power card EEPROM. The VLT frequency converter will continue to function, but is likely to fail at the next power-up. Contact your Danfoss supplier.

WARNING 20
Fault in the EEPROM on the control card (EE ERROR CONTROL)

There is a fault in the EEPROM on the control card. The VLT frequency converter will continue to function, but is likely to fail at the next power-up. Contact your Danfoss supplier.

ALARM: 22
Auto-optimisation not OK (AMA FAULT)

A fault has been found during automatic motor adaptation. The text shown in the display indicates a fault message.

NB!

AMA can only be carried out if there are no alarms during tuning.

CHECK 103, 105
[0]

Parameter 103 or 105 has a wrong setting. Correct the setting and start AMA all over.

LOW P.105
[1]

The motor is too small for AMA to be carried out. If AMA is to be enabled, the rated motor current (parameter 105) must be higher than 35% of the rated output current of the VLT frequency converter.

ASYMMETRICAL IMPEDANCE
[2]

AMA has detected an asymmetrical impedance in the motor connected to the system. The motor could be defective.

MOTOR TOO BIG
[3]

The motor connected to the system is too big for AMA to be carried out. The setting in parameter 102 does not match the motor used.

MOTOR TOO SMALL
[4]

The motor connected to the system is too small for AMA to be carried out. The setting in parameter 102 does not match the motor used.

TIME OUT
[5]

AMA fails because of noisy measuring signals. Try to start AMA all over a number of times, until AMA is carried out. Please note that repeated AMA runs may heat the motor to a level where the stator resistance R_s is increased. In most cases, however, this is not critical.

INTERRUPTED BY USER
[6]

AMA has been interrupted by the user.

INTERNAL FAULT
[7]

An internal fault has occurred in the VLT frequency converter. Contact your Danfoss supplier.

LIMIT VALUE FAULT
[8]

The parameter values found for the motor are outside the acceptable range within which the VLT frequency converter is able to work.

MOTOR ROTATES
[9]

The motor shaft rotates. Make sure that the load is not able to make the motor shaft rotate. Then start AMA all over.

Warnings and alarms, cont.**ALARM 29****Heat sink temperature too high
(HEAT SINK OVER TEMP):**

If the enclosure is IP 00 or IP 20, the cut-out temperature of the heat-sink is 90°C. If IP 54 is used, the cut-out temperature is 80°C.

The tolerance is $\pm 5^\circ\text{C}$. The temperature fault cannot be reset, until the temperature of the heat-sink is below 60°C.

The fault could be the following:

- Ambient temperature too high
- Too long motor cable
- Too high switching frequency.

ALARM: 30**Motor phase U missing
(MISSING MOT.PHASE U):**

Motor phase U between VLT frequency converter and motor is missing.

Turn off the VLT frequency converter and check motor phase U.

ALARM: 31**Motor phase V missing
(MISSING MOT.PHASE V):**

Motor phase V between VLT frequency converter and motor is missing.

Turn off the VLT frequency converter and check motor phase V.

ALARM: 32**Motor phase W missing
(MISSING MOT.PHASE U):**

Motor phase W between VLT frequency converter and motor is missing.

Turn off the VLT frequency converter and check motor phase W.

WARNING/ALARM: 34**HPFB communication fault
(HPFB COMM. FAULT)**

The serial communication on the communication option card is not working.

WARNING: 35**Out of frequency range
(OUT FREQ RNG/ROT LIM):**

This warning is active if the output frequency has reached its parameter 201 *Output frequency low limit* or parameter 202 *Output frequency high limit*.

ALARM: 37**Inverter fault (GATE DRIVE FAULT):**

IGBT or the power card is defective. Contact your Danfoss supplier.

Auto-optimisation warnings 39-42

Automatic motor adaptation has stopped, since some parameters have probably been set wrongly, or the motor used is too big/small for AMA to be carried out. A choice must thus be made by pressing [CHANGE DATA] and choosing 'Continue' + [OK] or 'Stop' + [OK].

If parameters need to be changed, select 'Stop'; start up AMA all over.

WARNING: 39**CHECK PAR. 104, 106**

Parameters 104 *Motor frequency* $f_{M,N}$, or 106 *Rated motor speed* $n_{M,N}$, have probably not been set correctly. Check the setting and select 'Continue' or [STOP].

WARNING: 40**CHECK PAR. 103, 105**

Parameter 103 *Motor voltage*, $U_{M,N}$ or 105 *Motor current*, $I_{M,N}$ has not been set correctly. Correct the setting and restart AMA.

WARNING: 41
MOTOR TOO BIG (MOTOR TOO BIG)

The motor used is probably too big for AMA to be carried out. The setting in parameter 102 *Motor power*, $P_{M,N}$ may not match the motor. Check the motor and choose 'Continue' or [STOP].

WARNING: 42
MOTOR TOO SMALL (MOTOR TOO SMALL)

The motor used is probably too small for AMA to be carried out. The setting in parameter 102 *Motor power*, $P_{M,N}$ may not match the motor. Check the motor and select 'Continue' or [STOP].

ALARM: 60
Safety stop (EXTERNAL FAULT)

Terminal 27 (parameter 304 *Digital inputs*) has been programmed for a *Safety interlock* [3] and is a logic '0'.

WARNING: 61
Output frequency low (FOUT < FLOW)

The output frequency is lower than parameter 223
Warning: Low frequency, f_{LOW} .

WARNING: 62
Output frequency high (FOUT > FHIGH)

The output frequency is higher than parameter 224
Warning: High frequency, f_{HIGH} .

WARNING/ALARM: 63
Output current low (I MOTOR < I LOW)

The output current is lower than parameter 221
Warning: Low current, I_{LOW} . Select the required function in parameter 409 *Function in case of no load*.

WARNING: 64
Output current high (I MOTOR > I HIGH)

The output current is higher than parameter 222
Warning: High current, I_{HIGH} .

WARNING: 65
Feedback low (FEEDBACK < FDB LOW)

The resulting feedback value is lower than parameter 227
Warning: Low feedback, FB_{LOW} .

WARNING: 66
Feedback high (FEEDBACK > FDB HIGH)

The resulting feedback value is higher than parameter 228
Warning: High feedback, FB_{HIGH} .

WARNING: 67
Remote reference low (REF. < REF LOW)

The remote reference is lower than parameter 225
Warning: Low reference, REF_{LOW} .

WARNING: 68
Remote reference high (REF. > REF HIGH)

The remote reference is higher than parameter 226
Warning: High reference, REF_{HIGH} .

WARNING: 99
Unknown fault (UNKNOWN ALARM)

An unknown fault has occurred which the software is not able to handle.
Contact your Danfoss supplier.

■ Aggressive environments

In common with all electronic equipment, a VLT frequency converter contains a large number of mechanical and electronic components, all of which are vulnerable to environmental effects to some extent.



The VLT frequency converter should not therefore be installed in environments with airborne liquids, particles or gases capable of affecting and damaging the electronic components. Failure to take the necessary protective measures increases the risk of stoppages, thus reducing the life of the VLT frequency converter.

Liquids can be carried through the air and condense in the VLT frequency converter. In addition to this, liquids may cause corrosion of components and metal parts.

Steam, oil and salt water may cause corrosion of components and metal parts.

In such environments, equipment with enclosure rating IP 54 is recommended.

Airborne particles such as dust particles may cause mechanical, electrical or thermal failure in the VLT frequency converter.

A typical indicator of excessive levels of airborne particles is dust particles around the VLT frequency converter fan.

In very dusty environments, equipment with enclosure rating IP 54 or a cabinet for IP 00/20 equipment is recommended.

In environments with high temperatures and humidity, corrosive gases such as sulphur, nitrogen and chlorine compounds will cause chemical processes on the VLT frequency converter components. Such chemical reactions will rapidly affect and damage the electronic components.

In such environments, it is recommended that equipment is mounted in a cabinet with fresh air ventilation, keeping aggressive gases away from the VLT frequency converter.

NOTE!

Mounting VLT frequency converters in aggressive environments will increase the risk of stoppages and furthermore considerably reduce the life of the converter.

Before the installation of the VLT frequency converter, the ambient air should be checked for liquids, particles and gases. This may be done by observing existing installations in this environment. Typical indicators of harmful airborne liquids are water or oil on metal parts, or corrosion of metal parts.

Excessive dust particle levels are often found on installation cabinets and existing electrical installations.

One indicator of aggressive airborne gases is blackening of copper rails and cable ends on existing installations.

■ Calculation of resulting reference

The calculation made below gives the resulting reference when parameter 210 *Reference type* is programmed for *Sum* [0] and *Relative* [1], respectively.

External reference is the sum of references from terminals 53, 54, 60 and serial communication. The sum of these can never exceed parameter 205 *Max. reference*.

External reference can be calculated as follows:

$$\text{Ext. ref.} = \frac{(\text{Par. 205 Max. ref.} - \text{Par. 204 Min. ref.}) \times \text{Ana. signal Term. 53 [V]}}{\text{Par. 310 Term. 53 Max. scaling} - \text{Par. 309 Term. 53 Min. scaling}} + \frac{(\text{Par. 205 Max. ref.} - \text{Par. 204 Min. ref.}) \times \text{Ana. signal Term. 54 [V]}}{\text{Par. 313 Term. 54 Max. scaling} - \text{Par. 312 Term. 54 Min. scaling}} + \frac{(\text{Par. 205 Max. ref.} - \text{Par. 204 Min. ref.}) \times \text{Par. 314 Term. 60 [mA]}}{\text{Par. 316 Term. 60 Max. scaling} - \text{Par. 315 Term. 60 Min. scaling}} + \frac{\text{serial com. reference} \times (\text{Par. 205 Max. ref.} - \text{Par. 204 Min. ref.})}{16384 \text{ (4000 Hex)}}$$

Par. 210 *Reference type* is programmed = *Sum* [0].

$$\text{Res. ref.} = \frac{(\text{Par. 205 Max. ref.} - \text{Par. 204 Min. ref.}) \times \text{Par. 211-214 Preset ref.}}{100} + \text{External ref.} + \text{Par. 204 Min. ref.} + \text{Par. 418/419 Setpoint (only in closed loop)}$$

Par. 210 *Reference type* is programmed = *Relative* [1].

$$\text{Res. ref.} = \frac{\text{External reference} \times \text{Par. 211-214 Preset ref.}}{100} + \text{Par. 204 Min. ref.} + \text{Par. 418/419 Setpoint (only in closed loop)}$$

Galvanic isolation (PELV)

PELV offers protection by way of extra low voltage. Protection against electric shock is considered to be ensured when the electrical supply is of the PELV type and the installation is made as described in local/national regulations on PELV supplies.

In VLT 6000 HVAC all control terminals as well as terminals 1-3 (AUX relay) are supplied from or in connection with extra low voltage (PELV).

Galvanic (ensured) isolation is obtained by fulfilling requirements concerning higher isolation and by providing the relevant creepage/clearance distances. These requirements are described in the EN 50178 standard.

For additional information on PELV see page 53.

Galvanic isolation

The components that make up the electrical isolation, as described below, also comply with the requirements concerning higher isolation and the relevant test as described in EN 50178.

The galvanic isolation can be shown in three locations (see drawing below), namely:

1. Power supply (SMPS) incl. signal isolation of U_{DC} , indicating the intermediate current voltage.
2. Gate drive that runs the IGBTs (trigger transformers/opto-couplers).
3. Current transducers (Hall effect current transducers).

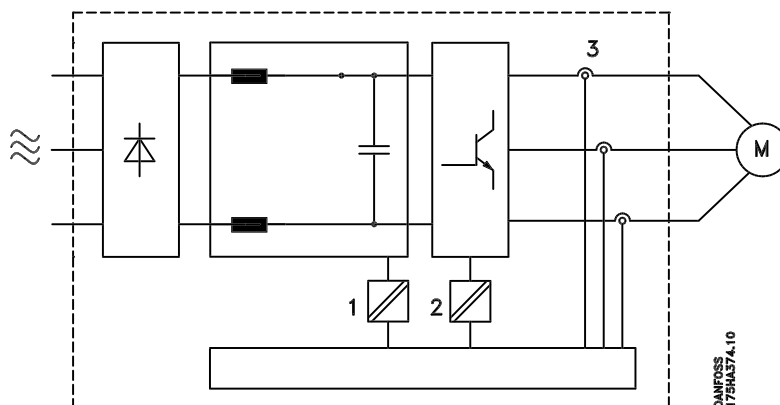

Earth leakage current

Earth leakage current is primarily caused by the capacitance between motor phases and the motor cable screen. When an RFI filter is used, this contributes additional leakage current, as the filter circuit is connected to earth through capacitors. See drawing on the following page.

The size of the leakage current to the ground depends on the following factors, in order of priority:

1. Length of motor cable
2. Motor cable with or without screen
3. Switching frequency
4. RFI filter used or not
5. Motor grounded on site or not

The leakage current is of importance to safety during handling/operation of the frequency converter if (by mistake) the frequency converter has not been earthed.



NB! RCD

Since the leakage current is > 3.5 mA, reinforced earthing must be established, which is required if EN 50178 is to be complied with. Never use ELCB relays (type A) that are not suitable for DC fault currents from three-phase rectifier loads.

If ELCB relays are used, they must be:

- Suitable for protecting equipment with a direct current content (DC) in the fault current (3-phase bridge rectifier)
- Suitable for power-up with short pulse-shaped charging current to earth
- Suitable for a high leakage current (300 mA)

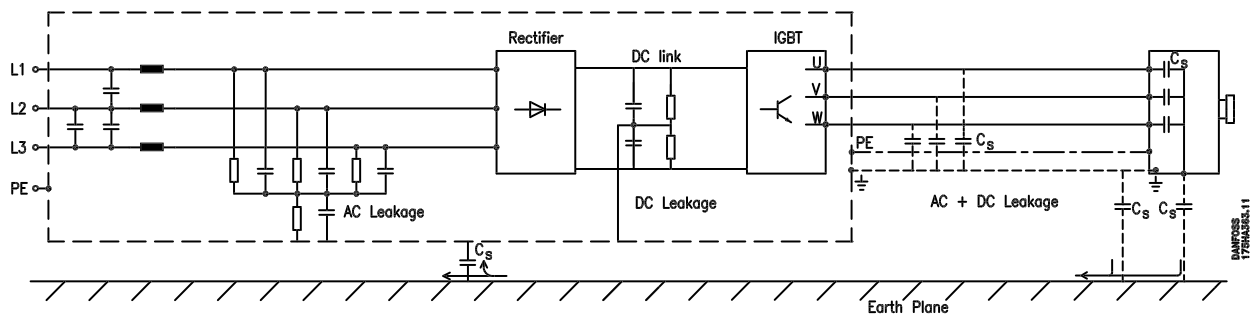

Leakage currents to earth

■ **Extreme running conditions**

Short circuit

VLT 6000 HVAC is protected against short circuits by means of current measurement in each of the three motor phases. A short circuit between two output phases will cause an overcurrent in the inverter. However, each transistor of the inverter will be turned off individually when the short circuit current exceeds the permitted value.

After 5-10 ms the driver card turns off the inverter and the frequency converter will display a fault code, although depending on impedance and motor frequency.

Earth fault

The inverter cuts out within 100 ms in case of an earth fault on a motor phase, although depending on impedance and motor frequency.

Switching on the output

Switching on the output between the motor and the frequency converter is fully permitted. It is not possible to damage VLT 6000 HVAC in any way by switching on the output. However, fault messages may appear.

Motor-generated overvoltage

The voltage in the intermediate circuit is increased when the motor acts as a generator. This occurs in two cases:

1. The load drives the motor (at constant output frequency from the frequency converter), i.e. the load generates energy.
2. During deceleration ("ramp-down") if the moment of inertia is high, the load is low and the ramp-down time is too short for the energy to be dissipated as a loss in the VLT frequency converter, the motor and the installation.

The control unit attempts to correct the ramp if possible.

The inverter turns off to protect the transistors and the intermediate circuit capacitors when a certain voltage level is reached.

Mains drop-out

During a mains drop-out, VLT 6000 HVAC continues until the intermediate circuit voltage drops below the minimum stop level, which is typically 15% below VLT 6000 HVAC's lowest rated supply voltage.

The time before the inverter stops depends on the mains voltage before the drop-out and on the motor load.

Static overload

When VLT 6000 HVAC is overloaded (the torque limit in parameter 215 *Current limit*, I_{LIM} has been reached), the controls will reduce the output frequency in an attempt to reduce the load.

If the overload is excessive, a current may occur that makes the VLT frequency converter cut out after approx. 1.5 sec.

Operation within the torque limit can be limited in time (0-60 s) in parameter 412 *Trip delay overcurrent*, I_{LIM} .

■ Peak voltage on motor

When a transistor in the inverter is opened, the voltage across the motor increases by a dV/dt ratio that depends on:

- the motor cable (type, cross-section, length screened/armoured or unscreened/unarmoured)
- inductance

The natural induction causes an overshoot U_{PEAK} in the motor voltage before it stabilises itself at a level which depends on the voltage in the intermediate circuit.

The rise time and the peak voltage U_{PEAK} affect the service life of the motor. If the peak voltage is too high, motors without phase coil insulation are the ones that will primarily be affected. If the motor cable is short (a few metres), the rise time and peak voltage are lower.

If the motor cable is long (100 m), the rise time and peak voltage will increase.

If very small motors are used without phase coil insulation, it is recommended to fit a LC filter after the frequency converter.

Typical values for the rise time and peak voltage U_{PEAK} measured on the motor terminals between two phases:

VLT 6002-6006 200 V, VLT 6002-6011 400 V

Cable length	Mains voltage	Rise time	Peak voltage
50 metres	380 V	0.3 μ sec.	850 V
50 metres	460 V	0.4 μ sec.	950 V
150 metres	380 V	1.2 μ sec.	1000 V
150 metres	460 V	1.3 μ sec.	1300 V

VLT 6008-6027 200 V, VLT 6016-6062 400 V

Cable length	Mains voltage	Rise time	Peak voltage
50 metres	380 V	0.1 μ sec.	900 V
150 metres	380 V	0.2 μ sec.	1000 V

■ Switching on the input

Switching on the input depends on the mains voltage in question.

The table below states the waiting time between cut-ins.

Mains voltage	380 V	415 V	460 V
Waiting time	74 s	95 s	123 s

■ Acoustic noise

The acoustic interference from the frequency converter comes from two sources:

1. DC intermediate circuit coils
2. Integral fan.

Below are the typical values measured at a distance of 1 m from the unit at full load:

VLT 6002-6006 200 V, VLT 6002-6011 400 V

IP 20 units: 50 dB(A)

VLT 6008-6027 200 V, VLT 6016-6062 400 V

IP 20 units: 61 dB(A)

IP 54 units: 66 dB(A)

■ Derating for ambient temperature

The ambient temperature ($T_{AMB,MAX}$) is the maximum temperature allowed. The average ($T_{AMB,AVG}$) measured over 24 hours must be at least 5°C lower.

If VLT 6000 HVAC is operated at temperatures above 45 °C, a derating of the continuous output current is necessary.

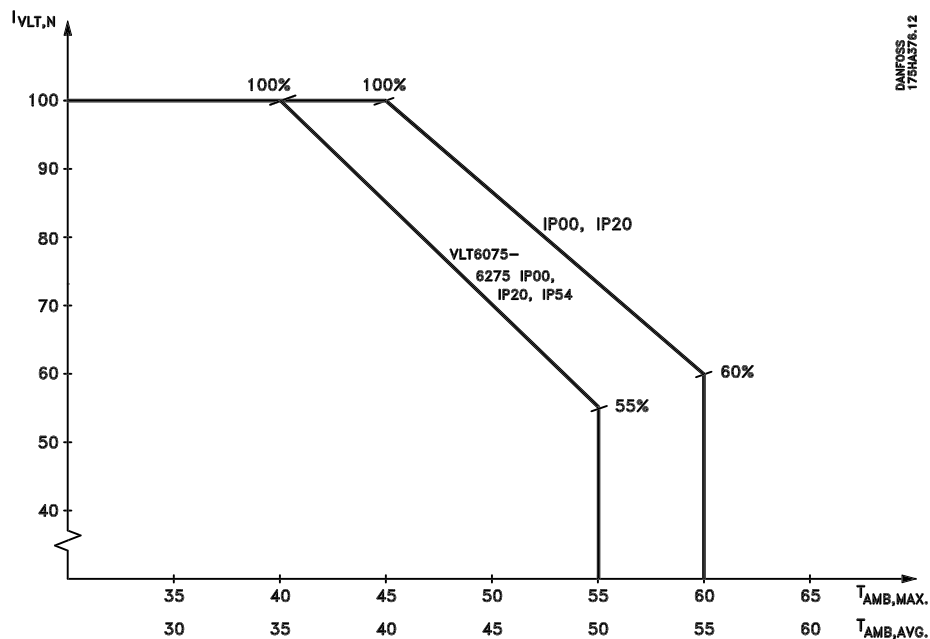

■ Derating for air pressure

Below 1000 m altitude no derating is necessary.

Above 1000 m the ambient temperature (T_{AMB}) or max. output current ($I_{VLT,MAX}$) must be derated in accordance with the diagram below:

- 1) Derating of output current versus altitude at $T_{AMB} = \text{max. } 45^{\circ}\text{C}$
- 2) Derating of max. T_{AMB} versus altitude at 100% output current.

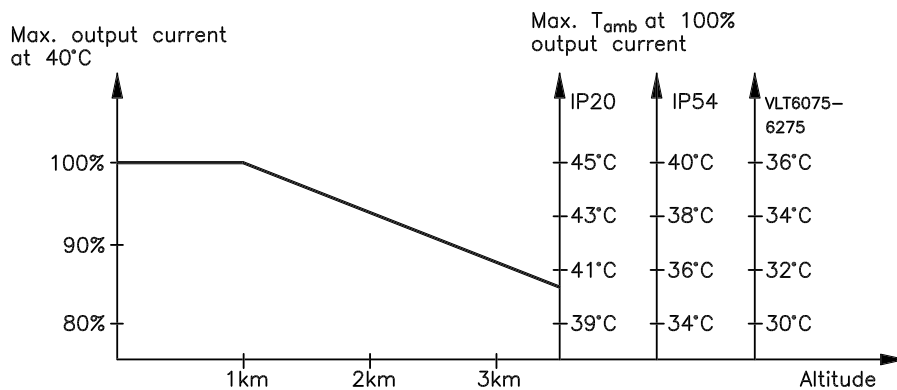

■ **Derating for running at low speed**

When a centrifugal pump or a fan is controlled by a VLT 6000 HVAC frequency converter, it is not necessary to reduce the output current at low speed because the load characteristic of the centrifugal pumps/fans, automatically ensures the necessary reduction.

■ **Derating for long motor cables or cables with larger cross-section**

VLT 6000 HVAC has been tested using 300 m unscreened/unarmoured cable and 150 m screened/armoured cable.

VLT 6000 HVAC has been designed to work using a motor cable with a rated cross-section. If a cable with a larger cross-section is to be used, it is recommended to reduce the output current by 5% for every step the cross-section is increased. (Increased cable cross-section leads to increased capacity to earth, and thus an increased earth leakage current).

■ **Derating for high switching frequency**

A higher switching frequency (to be set in parameter 407 *Switching frequency*) leads to higher losses in the electronics of the VLT frequency converter.

VLT 6000 HVAC has a pulse pattern in which it is possible to set the switching frequency from 3.0-10.0/14.0 kHz.

The VLT frequency converter will automatically derate the rated output current $I_{VLT,N}$, when the switching frequency exceeds 4.5 kHz.

In both cases, the reduction is carried out linearly, down to 60% of $I_{VLT,N}$.

The table gives the min., max. and factory-set switching frequencies for VLT 6000 HVAC units.

Switching frequency [kHz]	Min.	Max.	Fact.
VLT 6002-6005, 200 V	3.0	10.0	4.5
VLT 6006-6032, 200 V	3.0	14.0	4.5
VLT 6001-6011, 460 V	3.0	10.0	4.5
VLT 6016-6062, 460 V	3.0	14.0	4.5
VLT 6075-6275, 406 V	3.0	4.5	4.5

■ **Motor thermal protection**

The motor temperature is calculated on the basis of motor current, output frequency and time. See page 59.

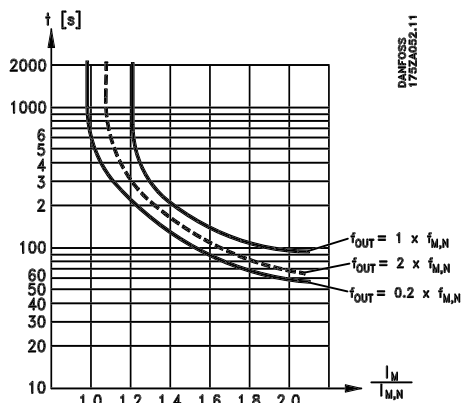

■ **Vibration and shock**

VLT 6000 HVAC has been tested according to a procedure based on the following standards:

- IEC 68-2-6: Vibration (sinusoidal) - 1970
- IEC 68-2-34: Random vibration broad-band - general requirements
- IEC 68-2-35: Random vibration broad-band - high reproducibility
- IEC 68-2-36: Random vibration broad-band - medium reproducibility

VLT 6000 HVAC complies with requirements that correspond to conditions when the unit is mounted on the walls and floors of production premises, as well as in panels bolted to walls or floors.

■ **Air humidity**

VLT 6000 HVAC has been designed to meet the IEC 68-2-3 standard, EN 50178 pkt. 9.4.2.2/DIN 40040, class E, at 40°C.

See specifications under *General technical data*.

All about VLT 6000 HVAC

■ Efficiency

To reduce energy consumption it is very important to optimize the efficiency of a system. The efficiency of each single element in the system should be as high as possible.

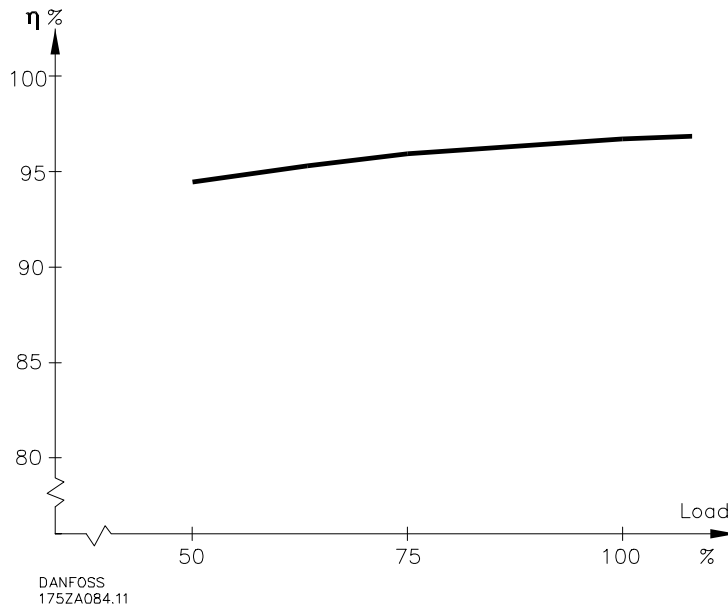

Efficiency of VLT 6000 HVAC (η_{VLT})

The load on the frequency converter has little effect on its efficiency. In general, the efficiency is the same at the rated motor frequency $f_{M,N}$, regardless of whether the motor supplies 100% of the rated shaft torque or only 75%, i.e. in case of part loads.

The efficiency declines a little when the switching frequency is set to a value of above 4 kHz (parameter 407 *Switching frequency*). The rate of efficiency will also be slightly reduced if the mains voltage is 460 V, or if the motor cable is longer than 30 m.

Efficiency of the motor (η_{MOTOR})

The efficiency of a motor connected to the frequency converter depends on the sine shape of the current. In general, the efficiency is just as good as with mains operation. The efficiency of the motor depends on the type of motor.

In the range of 75-100% of the rated torque, the efficiency of the motor is practically constant, both when it is controlled by the frequency converter and when it runs directly on mains.

In small motors, the influence from the U/f characteristic on efficiency is marginal; however, in motors from 11 kW and up, the advantages are significant.

In general, the switching frequency does not affect the efficiency of small motors. Motors from 11 kW and up have their efficiency improved (1-2%). This is because the sine shape of the motor current is almost perfect at high switching frequency.

Efficiency of the system (η_{SYSTEM})

To calculate the system efficiency, the efficiency of VLT 6000 HVAC (η_{VLT}) is multiplied by the efficiency of the motor (η_{MOTOR}):

$$\eta_{SYSTEM} = \eta_{VLT} \times \eta_{MOTOR}$$

Based on the graph outlined above, it is possible to calculate the system efficiency at different speeds.

■ Mains supply interference/harmonics

A frequency converter takes up a non-sinusoidal current from mains, which increases the input current I_{RMS} . A non-sinusoidal current can be transformed by means of a Fourier analysis and split up into sine wave currents with different frequencies, i.e. different harmonic currents I_N with 50 Hz as the basic frequency:

Harmonic currents	I_1	I_5	I_7
Hz	50 Hz	250 Hz	350 Hz

The harmonics do not affect the power consumption directly, but increase the heat losses in the installation (transformer, cables). Consequently, in plants with a rather high percentage of rectifier load, it is important to maintain harmonic currents at a low level to avoid overload of the transformer and high temperature in the cables.

Harmonic currents compared to the RMS input current:

	Input current
I_{RMS}	1.0
I_1	0.9
I_5	0.4
I_7	0.3
I_{11-49}	< 0.1

To ensure low, harmonic currents, VLT 6000 HVAC has intermediate circuit coils as standard. This normally reduces the input current I_{RMS} by 40%.

Some of the harmonic currents might disturb communication equipment connected to the same transformer or cause resonance in connection with power-factor correction batteries. VLT 6000 HVAC has been designed in accordance with the following standards:

- IEC 1000-3-4
- IEEE 519-1992
- IEC 22G/WG4
- EN 50178
- VDE 160, 5.3.1.1.2

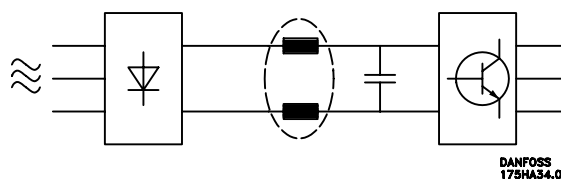

The voltage distortion on the mains supply depends on the size of the harmonic currents multiplied by the mains impedance for the frequency in question. The total voltage distortion THD is calculated on the basis of the individual voltage harmonics using the following formula:

$$THD\% = \sqrt{U_5^2 + U_7^2 + \dots + U_N^2} \quad (U_N\% \text{ of } U)$$

■ Power factor

The power factor is the relation between I_1 and I_{RMS} .

The power factor for 3-phase control

$$= \frac{\sqrt{3} \times U \times I_1 \times \cos \varphi_1}{\sqrt{3} \times U \times I_{RMS}}$$

$$\text{Power factor} = \frac{I_1 \times \cos \varphi}{I_{RMS}} = \frac{I_1}{I_{RMS}} \quad \text{since } \cos \varphi = 1$$

The power factor indicates the extent to which the frequency converter imposes a load on the mains supply.

The lower the power factor, the higher the I_{RMS} for the same kW performance.

In addition, a high power factor indicates that the different harmonic currents are low.

$$I_{RMS} = \sqrt{I_1^2 + I_5^2 + I_7^2 + \dots + I_n^2}$$

EMC test results (Emission, Immunity)

The following test results have been obtained using a system with a VLT frequency converter (with options if relevant), a screened/armoured control cable, a control box with potentiometer, as well as a motor and motor cable.

VLT 6002-6011/380-460 V VLT 6002-6005/200-240 V	Emission				
	Environment	Industrial environment		Residences and light industries	
	Basic standard	EN 55011 Class A1		EN 55011 Class B1	
Setup	Motor cable	Cable-borne 150 kHz-30 MHz	Radiated 30 MHz-1 GHz	Cable-borne 150 kHz-30 MHz	Radiated 30 MHz-1 GHz
VLT 6000 with integrated RFI filter	300 m unscreened/ unarmoured	Yes	No	No	No
	50 m screened/ armoured	Yes	Yes	Yes ¹⁾	No
	150 m screened/ armoured	Yes	Yes	No	No
VLT 6000 with integrated RFI + LC-module	300 m unscreened/ unarmoured	Yes	No	No	No
	150 m screened/ armoured	Yes	Yes	No	No
Comment					
1) Bookstyle 20 m screened/armoured.					

VLT 6016-6275/380-460 V VLT 6006-6042/200-240 V	Emission				
	Environment	Industrial environment		Residences and light industries	
	Basic standard	EN 55011 Class A1		EN 55011 Class B1	
Setup	Motor cable	Cable-borne 150 kHz-30 MHz	Radiated 30 MHz-1 GHz	Cable-borne 150 kHz-30 MHz	Radiated 30 MHz-1 GHz
VLT 6000 w/o RFI filter option	300 unscreened/ unarmoured	No	No	No	No
	150 m screened/ armoured	No	Yes	No	No
VLT 6000 with RFI filter (integrated)	300 m unscreened/ unarmoured	No	No	No	No
	50 m screened/ armoured	Yes	Yes	Yes	No
	150 m screened/ armoured	Yes	Yes	No	No
Comment					

In order to minimise the cable-borne noise to the mains supply and the radiated noise from the frequency converter system, the motor cables should be as short as possible and the screen ends should be made in accordance with the section on electrical installation.

■ Generic standards / Product standards

Standard/ Environment	Housing, trades and light industries		Industrial environment	
	Cable-borne	Radiated	Cable-borne	Radiated
EN 50081-1	Class B	Class B		
EN 50081-2			Class A-1	Class A-1
EN 61800-3 ¹⁾	Class B *	Class B *	Threshold values are being considered	
EN 61800-3 ²⁾	Class A-1	Class A-1	Threshold values are being considered	

* I < 25 A, klasse A-1 hvis I > 25 A.

1) Free sale (unrestricted)

2) Sale to professionals (restricted)

Class A-1:

Equipment used in a manufacturing environment.

Class B-1:

Equipment used in areas with a public supply network (dwellings, commerce and light industries).

EN 55011:

Threshold values and measuring methods for radio interference from industrial, scientific and medical (2)ISM high frequency equipment.

■ EMC Immunity

In order to confirm immunity against interference from electrical phenomena, the following immunity test has been made on a system consisting of a VLT frequency converter (with options, if relevant), a screened/armoured control cable and control box with potentiometer, motor cable and motor.

The tests were made in accordance with the following basic standards:

- **EN 61000-4-2 (IEC 1000-4-2): Electrostatic discharges (ESD)**
Simulation of electrostatic discharges from human beings.
- **EN 61000-4-3 (IEC 1000-4-3): Incoming electromagnetic field radiation, amplitude modulated**
Simulation of the effects of radar and radio communication equipment as well as mobile communications equipment.
- **EN 61000-4-4 (IEC 1000-4-4): Burst transients**
Simulation of interference brought about by switching with a contactor, relays or similar devices.
- **EN 61000-4-5 (IEC 1000-4-5): Surge transients**
Simulation of transients brought about e.g. by lightning that strikes near installations.
- **ENV 50204: Incoming electromagnetic field, pulse modulated**
Simulation of the impact from GSM telephones.
- **ENV 61000-4-6: Cable-borne HF**
Simulation of the effect of radio transmission equipment connected to supply cables.
- **VDE 0160 class W2 test pulse: Mains transients**
Simulation of high-energy transients brought about by main fuse breakage, switching of power factor-correction capacitors, etc.

■ Immunity, continued

VLT 6002-6250 380-460 V, VLT 6002-6027 200-240 V

Basic standard	Burst IEC 1000-4-4	Surge IEC 1000-4-5	ESD 1000-4-2	Radiated electro- magnetic field IEC 1000-4-3	Mains distortion VDE 0160	RF common mode voltage ENV 50141	Radiated radio freq.elect.field ENV 50140
	B	B	B	A		A	A
Acceptance criterion	B	B	B	A		A	A
Port connection	CM	DM CM		DM		DM	
Line	OK	OK OK	-	-		OK	-
Motor	OK	- -	-	-		-	-
Control lines	OK	- OK	-	-		OK	-
PROFIBUS option	OK	- OK	-	-		-	-
Signal Interface<3 m	OK	- -	-	-		-	-
Enclosure	-	- -	OK	OK		-	OK
Load sharing	OK	- -	-	-		OK	-
Standard bus	OK	- OK	-	-		OK	-
Basic specifications							
Line	4 kV/5kHz/DCN	2 kV/2Ω 4 kV/12Ω	-	-	2,3 x U _N ²⁾	10 V _{RMS}	-
Motor	4 kV/5kHz/CCC	- -	-	-	-	10 V _{RMS}	-
Control lines	2 kV/5kHz/CCC	- 2 kV/2Ω ¹⁾	-	-	-	10 V _{RMS}	-
PROFIBUS option	2 kV/5kHz/CCC	- 2 kV/2Ω ¹⁾	-	-	-	10 V _{RMS}	-
Signal interface<3 m	1 kV/5kHz/CCC	- -	-	-	-	10 V _{RMS}	-
Enclosure	-	- -	8 kV AD 6 kV CD	10 V/m	-	-	-
Load sharing	4 kV/5kHz/CCC	- -	-	-	-	10 V _{RMS}	-
Standard bus	2 kV/5kHz/CCC	- 4 kV/2Ω ¹⁾	-	-	-	10 V _{RMS}	-

DM: Differential mode

CM: Common mode

CCC: Capacitive clamp coupling

DCN: Direct coupling network

¹⁾ Injection on cable shield

²⁾ 2.3 x U_N: max. test pulse 380 V_{AC}: Class 2/1250 V_{PEAK}, 415 V_{AC}: Class 1/1350 V_{PEAK}

■ Definitions

Definitions are given in alphabetical order.

Analogue inputs:

The analogue inputs can be used for controlling various functions of the VLT frequency converter.

There are two types of analogue inputs:

Current input, 0-20 mA

Voltage input, 0-10 V DC.

Analogue ref.

A signal transmitted to input 53, 54 or 60. Can be voltage or current.

Analogue outputs:

There are two analogue outputs, which are able to supply a signal of 0-20 mA, 4-20 mA or a digital signal.

Automatic motor adjustment, AMA:

Automatic motor adjustment algorithm, which determines the electrical parameters for the connected motor, at standstill.

AWG:

Means American Wire Gauge, i.e. the American measuring unit for cable cross-section.

Control command:

By means of the control unit and the digital inputs, it is possible to start and stop the connected motor.

Functions are divided into two groups, with the following priorities:

Group 1 Reset, Coasting stop, Reset and Coasting stop, DC braking, Stop and the [OFF/STOP] key.

Group 2 Start, Pulse start, Reversing, Start reversing, Jog and Freeze output

Group 1 functions are called Start-disable commands. The difference between group 1 and group 2 is that in group 1 all stop signals must be cancelled for the motor to start. The motor can then be started by means of a single start signal in group 2.

A stop command given as a group 1 command results in the display indication STOP.

A missing stop command given as a group 2 command results in the display indication STAND BY.

Digital inputs:

The digital inputs can be used for controlling various functions of the VLT frequency converter.

Digital outputs:

There are four digital outputs, two of which activate a relay switch. The outputs are able to supply a 24 V DC (max. 40 mA) signal.

f_{JOG}

The output frequency from the VLT frequency converter transmitted to the motor when the jog function is activated (via digital terminals or serial communication).

f_M

The output frequency from the VLT frequency converter transmitted to the motor.

$f_{M,N}$

The rated motor frequency (nameplate data).

f_{MAX}

Maximum output frequency transmitted to the motor.

f_{MIN}

Minimum output frequency transmitted to the motor.

I_M

The current transmitted to the motor.

$I_{M,N}$

The rated motor current (nameplate data).

Initializing:

If initializing is carried out (see parameter 620 *Operating mode*), the VLT frequency converter returns to the factory setting.

$I_{VLT,MAX}$

The maximum output current.

$I_{VLT,N}$

The rated output current supplied by the VLT frequency converter.

LCP:

The control panel, which makes up a complete interface for control and programming of VLT 6000 HVAC. The control panel is detachable and may, as an alternative, be installed up to 3 metres away from the VLT frequency converter, i.e. in a front panel, by means of the installation kit option.

LSB:

Least significant bit.
Used in serial communication.

MCM:

Stands for Mille Circular Mil, an American measuring unit for cable cross-section.

MSB:

Most significant bit.
Used in serial communication.

 $n_{M,N}$

The rated motor speed (nameplate data).

 η_{VLT}

The efficiency of the VLT frequency converter is defined as the ratio between the power output and the power input.

On-line/off-line parameters:

On-line parameters are activated immediately after the data value is changed. Off-line parameters are not activated until OK has been entered on the control unit.

PID:

The PID regulator maintains the desired speed (pressure, temperature, etc.) by adjusting the output frequency to match the varying load.

 $P_{M,N}$

The rated power delivered by the motor (nameplate data).

Preset ref.

A permanently defined reference, which can be set from -100% to +100% of the reference range. There are four preset references, which can be selected via the digital terminals.

 Ref_{MAX}

The maximum value which the reference signal may have. Set in parameter 205 *Maximum reference*, Ref_{MAX} .

 Ref_{MIN}

The smallest value which the reference signal may have. Set in parameter 204 *Minimum reference*, Ref_{MIN} .

Setup:

There are four Setups, in which it is possible to save parameter settings. It is possible to change between the four parameter Setups and to edit one Setup, while another Setup is active.

Start-disable command:

A stop command that belongs to group 1 of the control commands - see this group.

Stop command:

See Control commands.

Thermistor:

A temperature-dependent resistor placed where the temperature is to be monitored (VLT or motor).

Trip:

A state which occurs in different situations, e.g. if the VLT frequency converter is subjected to an over-temperature. A trip can be cancelled by pressing reset or, in some cases, automatically.

Trip locked:

A state which occurs in different situations, e.g. if the VLT frequency converter is subject to an overtemperature. A locked trip can be cancelled by cutting off mains and restarting the VLT frequency converter.

 U_M

The voltage transmitted to the motor.

 $U_{M,N}$

The rated motor voltage (nameplate data).

 U_{VLT_MAX}

The maximum output voltage.

VT characteristics:

Variable torque characteristics, used for pumps and fans.

■ Factory settings

PNU #	Parameter description	Factory setting	Range	Changes during operation		4-Setup	Conversion index	Data type
				Yes	No			
001	Language	English		Yes	No		0	5
002	Active Setup	Setup 1		Yes	No		0	5
003	Copying of Setups	No copying		No	No		0	5
004	LCP copy	No copying		No	No		0	5
005	Max value of user-defined readout	100.00	0 - 999.999,99	Yes	Yes		-2	4
006	Unit for user-defined readout	No unit		Yes	Yes		0	5
007	Big display readout	Frequency, Hz		Yes	Yes		0	5
008	Small display readout 1.1	Reference , Unit		Yes	Yes		0	5
009	Small display readout 1.2	Motor current, A		Yes	Yes		0	5
010	Small display readout 1.3	Power, kW		Yes	Yes		0	5
011	Unit of local reference	Hz		Yes	Yes		0	5
012	Hand start on LCP	Enable		Yes	Yes		0	5
013	OFF/STOP on LCP	Enable		Yes	Yes		0	5
014	Auto start on LCP	Enable		Yes	Yes		0	5
015	Reset on LCP	Enable		Yes	Yes		0	5
016	Lock for data change	Not locked		Yes	Yes		0	5
017	Operating state at power-up, local control	Auto restart		Yes	Yes		0	5
100	Configuration	Open loop		No	Yes		0	5
101	Torque characteristics	Automatic Energy Optimisation		No	Yes		0	5
102	Motor power, $P_{M,N}$	Depends on the unit	0.25-300 kW	No	Yes		1	6
103	Motor voltage, $U_{M,N}$	Depends on the unit	200 - 500 V	No	Yes		0	6
104	Motor frequency, $f_{M,N}$	50 Hz	24-1000 Hz	No	Yes		0	6
105	Motor current, $I_{M,N}$	Depends on the unit	0.01 - $I_{VLT,MAX}$	No	Yes		-2	7
106	Rated motor speed, $n_{M,N}$	Depends on par. 102 Motor power	100-60000 rpm	No	Yes		0	6
107	Automatic motor adaptation, AMA	Optimisation disable		No	No		0	5
108	Start voltage of parallel motors	Depends on par. 103	0.0 - par. 103	Yes	Yes		-1	6
109	Resonance dampening	100 %	0 - 500 %	Yes	Yes		0	6
110	High brake-away torque	0.0 sec.	0.0 - 0.5 sec.	Yes	Yes		-1	5
111	Start delay	0.0 sec.	0.0 - 120.0 sec.	Yes	Yes		-1	6
112	Motor preheater	Disable		Yes	Yes		0	5
113	Motor preheater DC current	50 %	0 - 100 %	Yes	Yes		0	6
114	DC braking current	50 %	0 - 100 %	Yes	Yes		0	6
115	DC braking time	10.0 sec.	0.0 - 60.0 sec.	Yes	Yes		-1	6
116	DC brake cut-in frequency	OFF	0.0-par. 202	Yes	Yes		-1	6
117	Motor thermal protection	ETR trip 1		Yes	Yes		0	5

■ Factory settings

PNU #	Parameter description	Factory setting	Range	Changes 4-Setup		Conversion index	Data type
				during operation			
200	Output frequency range	0 - 120 Hz	0 - 1000 Hz	No	Yes	0	5
201	Output frequency low limit, f_{MIN}	0.0 Hz	0.0 - f_{MAX}	Yes	Yes	-1	6
202	Output frequency high limit, f_{MAX}	50 Hz	f_{MIN} - par. 200	Yes	Yes	-1	6
203	Reference site	Hand/Auto linked reference		Yes	Yes	0	5
204	Minimum reference, Ref_{MIN}	0.000	0.000-par. 100	Yes	Yes	-3	4
205	Maximum reference, Ref_{MAX}	50.000	par. 100-999.999,999	Yes	Yes	-3	4
206	Ramp-up time	Depends on the unit	1 - 3600	Yes	Yes	0	7
207	Ramp-down time	Depends on the unit	1 - 3600	Yes	Yes	0	7
208	Automatic ramp-up/down	Enable		Yes	Yes	0	5
209	Jog frequency	10.0 Hz	0.0 - par. 100	Yes	Yes	-1	6
210	Reference type	Sum		Yes	Yes	0	5
211	Preset reference 1	0.00 %	-100.00 - 100.00 %	Yes	Yes	-2	3
212	Preset reference 2	0.00 %	-100.00 - 100.00 %	Yes	Yes	-2	3
213	Preset reference 3	0.00 %	-100.00 - 100.00 %	Yes	Yes	-2	3
214	Preset reference 4	0.00 %	-100,00 - 100,00 %	Yes	Yes	-2	3
215	Current limit, I_{LIM}	1.0 x $I_{VLT,N}$ [A]	0,1-1,1 x $I_{VLT,N}$ [A]	Yes	Yes	-1	6
216	Frequency bypass, bandwidth	0 Hz	0 - 100 Hz	Yes	Yes	0	6
217	Frequency bypass 1	120 Hz	0.0 - par. 200	Yes	Yes	-1	6
218	Frequency bypass 2	120 Hz	0.0 - par. 200	Yes	Yes	-1	6
219	Frequency bypass 3	120 Hz	0.0 - par. 200	Yes	Yes	-1	6
220	Frequency bypass 4	120 Hz	0.0 - par. 200	Yes	Yes	-1	6
221	Warning: Low current, I_{LOW}	0.0 A	0.0 - par. 222	Yes	Yes	-1	6
222	Warning: High current, I_{HIGH}	$I_{VLT,MAX}$	Par. 221 - $I_{VLT,MAX}$	Yes	Yes	-1	6
223	Warning: Low frequency, f_{LOW}	0.0 Hz	0.0 - par. 224	Yes	Yes	-1	6
224	Warning: High frequency, f_{HIGH}	120.0 Hz	Par. 223 - par. 200/202	Yes	Yes	-1	6
225	Warning: Low reference, Ref_{LOW}	0.0 Hz	-999,999.999 - par. 226	Yes	Yes	-3	4
226	Warning: High reference, Ref_{HIGH}	50.0 Hz	Par. 225 - 999,999.999	Yes	Yes	-3	4
227	Warning: Low feedback, FB_{LOW}	0.000	-999,999.999 - par. 228	Yes	Yes	-3	4
228	Warning: High feedback, FB_{HIGH}	100.000	Par. 227 - 999,999.999	Yes	Yes	-3	4

Changes during operation:

"Yes" means that the parameter can be changed, while the VLT frequency converter is in operation. "No" means that the VLT frequency converter must be stopped before a change can be made.

4-Setup:

"Yes" means that the parameter can be programmed individually in each of the four setups, i.e. the same parameter can have four different data values. "No" means that the data value will be the same in all four setups.

Conversion index:

This number refers to a conversion figure to be used when writing or reading to or from a VLT frequency converter by means of serial communication.

Conversion index

Conversion index	Conversion factor
74	3.6
2	100
1	10
0	1
-1	0.1
-2	0.01
-3	0.001
-4	0.0001

Data type:

Data type shows the type and length of the telegram.

Data type	Description
3	Integer 16
4	Integer 32
5	Unsigned 8
6	Unsigned 16
7	Unsigned 32
9	Text string

Factory settings

PNU #	Parameter description	Factory setting	Range	Changes during operation		4-Setup	Conversion index	Data type
				Yes	No			
300	Terminal 16 Digital input	Reset		Yes	Yes		0	5
301	Terminal 17 Digital input	Freeze output		Yes	Yes		0	5
302	Terminal 18 Digital input	Start		Yes	Yes		0	5
303	Terminal 19 Digital input	Reversing		Yes	Yes		0	5
304	Terminal 27 Digital input	Coasting stop, inverse		Yes	Yes		0	5
305	Terminal 29 Digital input	Jog		Yes	Yes		0	5
306	Terminal 32 Digital input	No operation		Yes	Yes		0	5
307	Terminal 33 Digital input	No operation		Yes	Yes		0	5
308	Terminal 53, analogue input voltage	Reference		Yes	Yes		0	5
309	Terminal 53, min. scaling	0.0 V	0.0 - 10.0 V	Yes	Yes		-1	5
310	Terminal 53, max. scaling	10.0 V	0.0 - 10.0 V	Yes	Yes		-1	5
311	Terminal 54, analogue input voltage	No operation		Yes	Yes		0	5
312	Terminal 54, min. scaling	0.0 V	0.0 - 10.0 V	Yes	Yes		-1	5
313	Terminal 54, max. scaling	10.0 V	0.0 - 10.0 V	Yes	Yes		-1	5
314	Terminal 60, analogue input current	Reference		Yes	Yes		0	5
315	Terminal 60, min. scaling	4.0 mA	0.0 - 20.0 mA	Yes	Yes		-4	5
316	Terminal 60, max. scaling	20.0 mA	0.0 - 20.0 mA	Yes	Yes		-4	5
317	Time out	10 sec.	1 - 99 sec.	Yes	Yes		0	5
318	Function after time out	Off		Yes	Yes		0	5
319	Terminal 42, output	0 - I _{MAX} ⇒ 0-20 mA		Yes	Yes		0	5
320	Terminal 42, output, pulse scaling	5000 Hz	1 - 32000 Hz	Yes	Yes		0	6
321	Terminal 45, output	0 - f _{MAX} ⇒ 0-20 mA		Yes	Yes		0	5
322	Terminal 45, output, pulse scaling	5000 Hz	1 - 32000 Hz	Yes	Yes		0	6
323	Relay 1, output function	Alarm		Yes	Yes		0	5
324	Relay 01, ON delay	0.00 sec.	0 - 600 sec.	Yes	Yes		0	6
325	Relay 01, OFF delay	0.00 sec.	0 - 600 sec.	Yes	Yes		0	6
326	Relay 2, output function	Running		Yes	Yes		0	5
327	Pulse reference, max. frequency	5000 Hz	Depends on input terminal	Yes	Yes		0	6
328	Pulse feedback, max. frequency	25000 Hz	0 - 65000 Hz	Yes	Yes		0	6

Changes during operation:

"Yes" means that the parameter can be changed, while the VLT frequency converter is in operation. "No" means that the VLT frequency converter must be stopped before a change can be made.

4-Setup:

"Yes" means that the parameter can be programmed individually in each of the four setups, i.e. the same parameter can have four different data values. "No" means that the data value will be the same in all four setups.

Conversion index:

This number refers to a conversion figure to be used when writing or reading to or from a VLT frequency converter by means of serial communication.

Conversion index

Conversion index	Conversion factor
74	3.6
2	100
1	10
0	1
-1	0.1
-2	0.01
-3	0.001
-4	0.0001

Data type:

Data type shows the type and length of the telegram.

Data type	Description
3	Integer 16
4	Integer 32
5	Unsigned 8
6	Unsigned 16
7	Unsigned 32
9	Text string

■ Factory settings

PNU #	Parameter description	Factory setting	Range	Changes during operation	4-Setup	Conversion index	Data type
400	Reset function	Manual reset		Yes	Yes	0	5
401	Automatic restart time	10 sec.	0 - 600 sec.	Yes	Yes	0	6
402	Flying start	Enable		Yes	Yes	-1	5
403	Sleep mode timer	Off	0 - 300 sec.	Yes	Yes	0	6
404	Sleep frequency	0 Hz	f_{MIN} - Par. 405	Yes	Yes	-1	6
405	Wake up frequency	50 Hz	Par. 404 - f_{MAX}	Yes	Yes	-1	6
406	Boost setpoint	100%	1 - 200 %	Yes	Yes	0	6
407	Switching frequency	Depends on the unit	3.0 - 14.0 kHz	Yes	Yes	2	5
408	Interference reduction method	ASFM		Yes	Yes	0	5
409	Function in case of no load	Warning		Yes	Yes	0	5
412	Trip delay overcurrent, I_{LM}	60 sec	0 - 60 sec.	Yes	Yes	0	5
413	Minimum feedback, FB_{MIN}	0.000	-999,999.999 - FB_{MIN}	Yes	Yes	-3	4
414	Maximum feedback, FB_{MAX}	100.000	FB_{MIN} - 999,999.999	Yes	Yes	-3	4
415	Units relating to closed loop	%		Yes	Yes	-1	5
416	Feedback conversion	Linear		Yes	Yes	0	5
417	Feedback calculation	Minimum		Yes	Yes	0	5
418	Setpoint 1	0.000	FB_{MIN} - FB_{MAX}	Yes	Yes	-3	4
419	Setpoint 2	0.000	FB_{MIN} - FB_{MAX}	Yes	Yes	-3	4
420	PID normal/inverse control	Normal		Yes	Yes	0	5
421	PID anti windup	On		Yes	Yes	0	5
422	PID start-up frequency	0 Hz	f_{MIN} - f_{MAX}			-1	6
423	PID proportional gain	0.01	0.00 - 10.00	Yes	Yes	-2	6
424	PID start-up frequency	Off	0.01 - 9999.00 s. (Off)	Yes	Yes	-2	7
425	PID differentiation time	Off	0.0 (Off) - 10.00 sec.	Yes	Yes	-2	6
426	PID differentiator gain limit	5.0	5.0 - 50.0	Yes	Yes	-1	6
427	PID lowpass filter time	0.01	0.01 - 10.00	Yes	Yes	-2	6

■ Factory settings

PNU #	Parameter description	Factory setting	Range	Changes during operation	4-Setup	Conversion index	Data type
500	Protocol	FC protocol		Yes	Yes	0	5
501	Address	1	Depends on par. 500	Yes	No	0	6
502	Baudrate	9600 Baud		Yes	No	0	5
503	Coasting	Logic or		Yes	Yes	0	5
504	DC-brake	Logic or		Yes	Yes	0	5
505	Start	Logic or		Yes	Yes	0	5
506	Direction of rotation	Logic or		Yes	Yes	0	5
507	Selection of Setup	Logic or		Yes	Yes	0	5
508	Selection of preset reference	Logic or		Yes	Yes	0	5
509	Data read-out: Reference %			No	No	-1	3
510	Data read-out: Reference unit			No	No	-3	4
511	Data read-out: Feedback			No	No	-3	4
512	Data read-out: Frequency			No	No	-1	6
513	User defined read-out			No	No	-2	7
514	Data read-out: Current			No	No	-2	7
515	Data read-out: Power, kW			No	No	1	7
516	Data read-out: Power, HP			No	No	-2	7
517	Data read-out: Motor voltage			No	No	-1	6
518	Data read-out: DC link voltage			No	No	0	6
519	Data read-out: Motor temp.			No	No	0	5
520	Data read-out: VLT temp.			No	No	0	5
521	Data read-out: Digital input			No	No	0	5
522	Data read-out: Terminal 53, analogue input			No	No	-1	3
523	Data read-out: Terminal 54, analogue input			No	No	-1	3
524	Data read-out: Terminal 60, analogue input			No	No	4	3
525	Data read-out: Pulse reference			No	No	-1	7
526	Data read-out: External reference %			No	No	-1	3
527	Data read-out: Status word, hex			No	No	0	6
528	Data read-out: Heat sink temperature			No	No	0	5
529	Data read-out: Alarm word, hex			No	No	0	7
530	Data read-out: Control word, hex			No	No	0	6
531	Data read-out: Warning word, hex			No	No	0	7
532	Data read-out: Extended status word, hex			No	No	0	7
533	Display text 1			No	No	0	9
534	Display text 2			No	No	0	9
535	Busfeedback 1			No	No	0	3
536	Busfeedback 2			No	No	0	3
555	Bus time interval	1 sec.	1 - 99 sec.	Yes	Yes	0	5
556	Bus time interval function	OFF		Yes	Yes	0	5

■ Factory settings

PNU #	Parameter description	Factory setting	Range	Changes during operation	4-Setup	Conversion index	Data type
600	Operating data: Operating hours			No	No	74	7
601	Operating data: Hours run			No	No	74	7
602	Operating data: kWh counter			No	No	2	7
603	Operating data: No. of cut-ins			No	No	0	6
604	Operating data: No. of overtemps			No	No	0	6
605	Operating data: No. of overvoltages			No	No	0	6
606	Data log: Digital input			No	No	0	5
607	Data log: Control word			No	No	0	6
608	Data log: Status word			No	No	0	6
609	Data log: Reference			No	No	-1	3
610	Data log: Feedback			No	No	-3	4
611	Data log: Output frequency			No	No	-1	3
612	Data log: Output voltage			No	No	-1	6
613	Data log: Output current			No	No	-2	3
614	Data log: DC link voltage			No	No	0	6
615	Fault log: Error code			No	No	0	5
616	Fault log: Time			No	No	0	7
617	Fault log: Value			No	No	0	3
618	Reset of kWh counter	No reset		Yes	No	0	5
619	Reset of hours-run counter	No reset		Yes	No	0	5
620	Operating mode	Normal function		Yes	No	0	5
621	Nameplate: Unit type			No	No	0	9
622	Nameplate: Power component			No	No	0	9
623	Nameplate: VLT ordering no.			No	No	0	9
624	Nameplate: Software version no.			No	No	0	9
625	Nameplate: LCP identification no.			No	No	0	9
626	Nameplate: Database identification no.			No	No	-2	9
627	Nameplate: Power component identification no.			No	No	0	9
628	Nameplate: Application option type			No	No	0	9
629	Nameplate: Application option ordering no.			No	No	0	9
630	Nameplate: Communication option type			No	No	0	9
631	Nameplate: Communication option ordering no.			No	No	0	9

Changes during operation:

"Yes" means that the parameter can be changed, while the VLT frequency converter is in operation.
 "No" means that the VLT frequency converter must be stopped before a change can be made.

4-Setup:

"Yes" means that the parameter can be programmed individually in each of the four setups, i.e. the same parameter can have four different data values. "No" means that the data value will be the same in all four setups.

Conversion index:

This number refers to a conversion figure to be used when writing or reading to or from a VLT frequency converter by means of serial communication.

Conversion index	Conversion factor
74	3.6
2	100
1	10
0	1
-1	0.1
-2	0.01
-3	0.001
-4	0.0001

Data type:

Data type shows the type and length of the telegram.

Data type	Description
3	Integer 16
4	Integer 32
5	Unsigned 8
6	Unsigned 16
7	Unsigned 32
9	Text string

A		E	
Acoustic noise	159	Efficiency	162
Address	132	Electrical installation	
Air humidity	161	Connection examples	68
Alarm word	140	control cables	65
Alarms	150	Direction of motor rotation	63
Analogue output	103	Earthing of screened/armoured control cables	56
Anti windup	118	EMC-correct cables	52, 55
Application functions 400-427	108	EMC-correct electrical installation	54
Auto start	70	Parallel coupling of motors	63
Automatic Energy Optimisation	81	Pre-fuses	62
AWG	167	serial communication	56
		Switches 1-4	67
B		EMC Immunity	165
Baudrate	132	EMC test results	164
Broadcast	121	Enclosures	57
Bus feedback	138	Extra protection	52
		Extreme running conditions	
C		Earth fault	158
Cable clamp	56	Mains drop-out	158
Cables	52	Motor-generated overvoltage	158
Closed loop	81	Short circuit	158
Configuration	81	Static overload	158
Connection examples	68	Switching on the output	158
Control and reply telegrams	121		
Control keys	69	F	
Control unit LCP	69	Factory settings	169
Conversion index	170	Factory Setup	75
Correct earthing	56	Fault log	144
Current limit	93, 152	FC protocol	121
		Feedback	
D		conversion	116
Data character	123	handling	115
Data control byte	123	Maximum	112
Data log	143	Minimum	112
Data read-out	136	signal	100
Data type	169	two feedback	117
DC braking	86	Field-mounting	50
DC bus connection	64	Flying start	108
Definitions	167	Frequency bypass	93
Derating		Function in	
for air pressure	160	case of no load	111
for ambient temperature	160, 162		
for high switching frequency	161	G	
for installing long motor cables	161	Galvanic isolation	157
Digital inputs	97	Generic standards	165
Display line 2	77		
Display Mode	70		
Display text	138		
dV/dt	159		

H		P	
Hand start	70	Parallel coupling	63
Hand/Auto linked reference	90	PELV	157
Harmonics	163	PID	
High voltage test	53	anti windup	118
High-voltage relay	64	differentiation time	119
I		differentiator gain limit	119
Immunity	165	integration time	119
Inputs and outputs 300-328	97	lowpass filter time	120
Interference reduction method	111	normal/inverse control	118
Interference/harmonics	163	proportional gain	119
J		start-up frequency	118
Jog frequency	91	PID for process control	113
L		Pre-fuses	62
LC filter	111	Preset reference	93
Load and Motor 100-117	81	Protocols	121
Local reference	90	Pulse reference	99
M		Q	
Mains connection	62	Quick setup menu	74
Mains drop-out	158	R	
Mechanical dimensions	48	Ramp	91
Mechanical installation		RCD	157
Cooling	50	Reference function	92
Side-by-side	50	Reference handling	89
Motor		References & Limits 200 - 228	88
cables	63	Relay outputs	106
connection	62	Remote reference	90
current	83	Reset	70
Direction of motor rotation	63	Reset function	108
Efficiency	162	RFI switch	53
frequency	83	S	
Parallel coupling of motors	63	Serial communication	121
power	82	Service functions 600-631	142
speed	83	Setpoint	117
voltage	82	Setup configuration	75
Motor thermal protection	64, 87, 161	Short circuit	158
Motor thermistor	152	Side-by-side	50
Motor-generated overvoltage	158	Sleep mode	109
MultiSetup	75	Start delay	85
N		Static overload	158
Nameplate	146	Status messages	148
O		Switch 1-4	67
Operating data	142	Switching frequency	110
Operation and Display 000-017	75	Switching on the input	159
Output frequency	88	Switching on the output	158

T

Technical data

General technical data	42
Technical data, mains supply 3 x 380 - 460 V	46
Technical data, mains supply 3 x 200 - 240 V	45
Telegram build-up	122
Telegram length	122
Time out	102
Trip locked	168

U

User-defined readout	76
----------------------------	----

V

Vibration and shock	161
---------------------------	-----

W

Warning

feedback	96
frequency	95
Low current	94
reference	95
Warning words	140
Warnings	150